



3.4 POST CONSTRUCTION STORMWATER CONTROL FACT SHEETS (PTP)

| Post Construction Stormwater Control Practices | 3.4.1 Sand Filters |
|--|---|
| <div data-bbox="253 499 423 596" data-label="Image"> </div> <p data-bbox="201 800 444 829">TSS Reduction: 80%</p> | <div data-bbox="511 422 1421 1102" data-label="Image"> </div> <p data-bbox="786 1104 1170 1136">Figure PTP-01- 1 Surface Sand Filter</p> <p data-bbox="602 1138 1289 1218">Showing the sedimentation (foreground) and the filter bed (background) <i>Source, Center for Watershed Protection and Stormwater Managers Resource Center.</i></p> |
| <p data-bbox="201 1249 345 1278">Description</p> | <p data-bbox="506 1249 1451 1612">Sand filters are structural water quality control devices that capture and temporarily store, treat, and release stormwater runoff by passing the stormwater through a sand media. Sand filters consist of two main components: a pretreatment basin and filtration chamber. The pretreatment basin removes floatable materials and heavy sediments, and helps reduce flow velocities. The filtration chamber traps and strains pollutants, and in some instances allows the microbial removal of pollutants. Target pollutants for sand filters include suspended solids, suspended particulates, biochemical oxygen demand (BOD), fecal coliform bacteria, and others. The pretreatment basin and filtration chamber must also include an underdrain collection system to return stormwater to a conveyance system, and may also include or be enhanced by one or more of the following components: grass buffer strips, ponding area, sand bed, and plant material.</p> <p data-bbox="506 1646 1115 1675">Sand filters types documented in this fact sheet include:</p> <ul data-bbox="581 1698 867 1818" style="list-style-type: none"> ➤ Surface sand filters ➤ Underground sand filters ➤ Perimeter sand filters |



Applications

Sand filters are often used to manage stormwater runoff from urban areas where space is limited, and can be applied to areas where retrofit is needed, and are typically suitable in the following applications:

- Small stabilized drainage areas up to 5 acres (up to 10 acres for surface sand filters)
- Areas with low sediment loads and high pollutant loads
- Impervious area runoff – well suited for greater than 50% impervious area
- Off-line facilities adjacent to parking lots
- Underground installation
- Retrofit applications

Sand filters are **not** suitable in the following applications:

- Water *quantity* control
- Within drainage areas that have not been stabilized
- Residential applications
- Adjacent to areas with slopes greater than 5:1 (H:V) or 20%
- Areas that experience continuous flow from surface water, groundwater, sump pumps, or other sources

The use of sand filters as a retrofit practice primarily depends on existing infrastructure and the compatibility of existing storm drain inverts that need to connect to the filter under-drain outflow. In general, four to six feet of elevation above the existing collection system invert is needed for sand filter retrofits (2-3 feet is needed for perimeter filters). Underground sand filters are excellent for ultra-urban settings where space is at a premium.

Sand filters should only be applied in stabilized drainage areas, as heavy sediment loads from construction areas will clog and disable the filter. Likewise, they should not be used in areas where stormwater has the potential for high silt or clay content, and areas with a high water table. As a guide, sites implementing sand filters should have over 50% impervious cover in the drainage area.

Sand filters are designed for off-line use to capture the water quality volume (WQ_v). A diversion structure such as a flow splitter or weir may be necessary to separate and route the WQ_v to the sand filter, allowing larger stormwater flows to bypass the water quantity control device. For designs where no flow splitter is used, the recommended contributing drainage area should be limited to about 0.5 acres with an overflow at the filter to pass part of the WQ_v to a stabilized watercourse or storm drain. Where a flow splitter will be used, the flow splitter should allow 75% of the WQ_v to enter the filter system before allowing flows to bypass the system to a stabilized outlet. The sand filter can be adjusted to minimize bypassing before filling the filter to 75% of the WQ_v by adjusting the elevation of the overflow weir between the sedimentation and filter chambers so that the overflow weir elevation is lower than the flow splitter weir elevation. Sand filters are most effective when turbulent flow is minimized and the flow is spread uniformly across the filter media.



Sand Filter Variations

Sand filters are an excellent stormwater treatment practice with the primary pollutant removal mechanism being filtering and settling. Less significant processes can include evaporation, infiltration, transpiration, biological and microbiological uptake, and soil absorption. While it is possible to design sand filters to discharge a portion of the effluent to the ground water, applications in Bowling Green are typically designed as enclosed systems that discharge to a specific discharge location due to the widespread presence of karst geology.

➤ Surface Sand Filters



Figure PTP-01- 2 Surface Sand Filter

Showing the sedimentation (foreground) and the filter bed (background)
Source, Stormwater Managers Resource Center.

Surface sand filters are open-air, at-grade structures that serve as off-line water quality systems and include two system components. A flow diversion such as a flow splitter diverts runoff into the off-line surface filter. The first component is a sediment forebay or sedimentation chamber. Flow enters the forebay where heavier sediment particles settle out of suspension. This pre-treatment forebay may be either wet or dry. A perforated standpipe moves pre-treated runoff from the first component to the second. The second component is a filter bed chamber or filtration chamber with an approximately 18-inch thick sand bed. Runoff is temporarily stored above the bed, with pollutants filtered out at the bed surface. The top bed surface is covered with either sand or grass. Runoff exiting the bed bottom is collected by the underdrain system and discharged to the outflow.

Surface sand filters are suitable for multiple location types and use different configurations. For effective pollutant removal with surface sand filters, the contributing drainage areas should be no more than 10 acres. The two components may be designed using riprap, excavations with earthen embankments, a concrete structure or a block structure. For earthen embankments, the bottom and side slopes of the earthen walls should be lined with a permeable filter fabric before installing the filtration system and underdrain. See Figures PTP-01-3, PTP-01-4 and PTP-01-5 for the typical surface sand filter schematics.



City of Berea
Stormwater Manual Best Management Practices

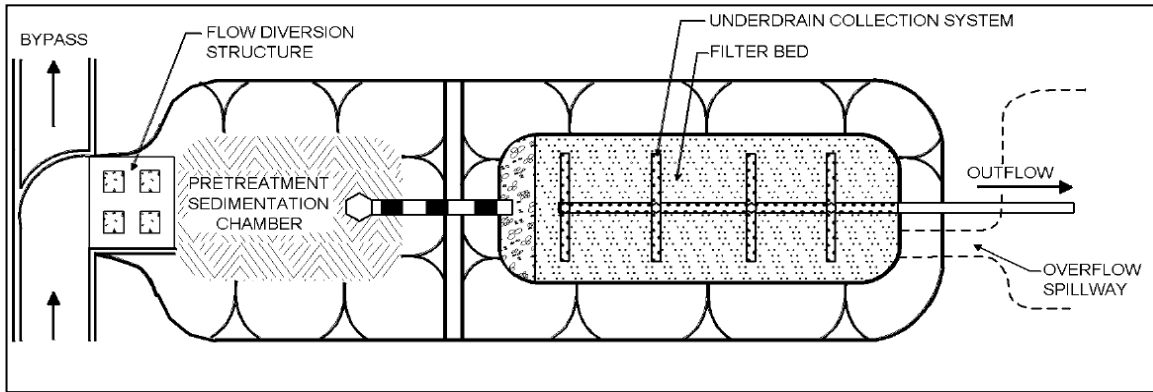

Figure PTP-01- 3 Surface Sand Filter
Source, Georgia Stormwater Management Manual

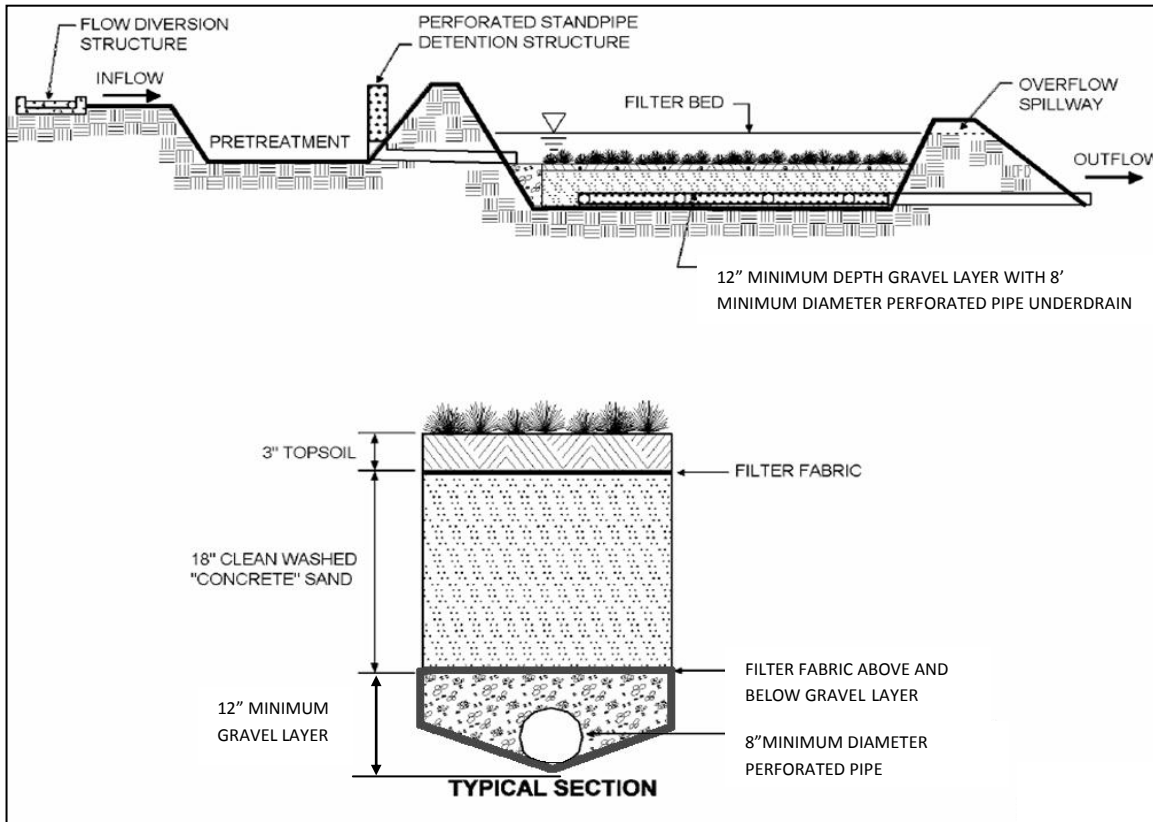
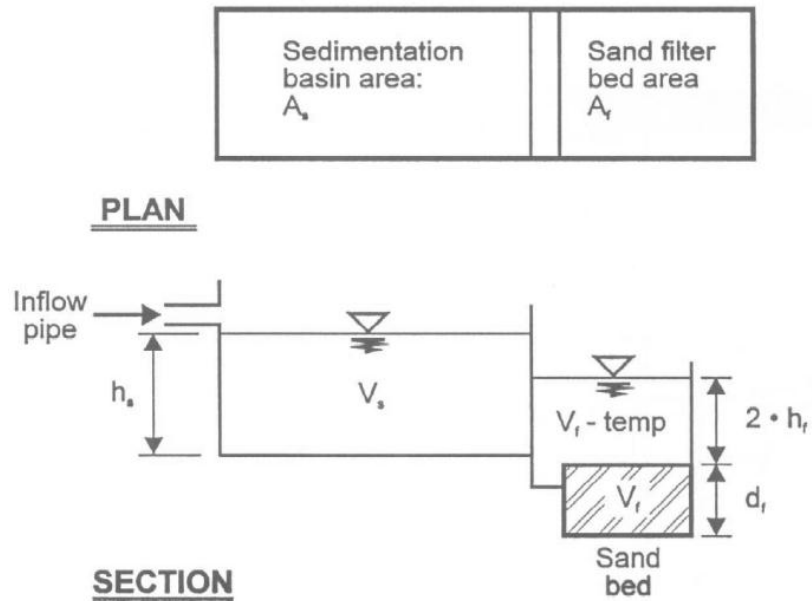

Figure PTP-01- 4 Surface Sand Filter (cross sectional view)
Source, Georgia Stormwater Management Manual



**Sand Filter
Variations**



- V_s = Sedimentation basin volume
- V_f = Volume of voids in the filter bed
- V_{f-temp} = Temporary volume stored above the filter bed
- A_s = Surface area of the sedimentation basin
- A_f = Surface area of the filter media
- h_s = Depth of water in the sedimentation basin
- h_f = Average depth of water above the filter media
- d_f = Depth of the filter media

Figure PTP-01- 5 Surface Sand Filter (cross sectional view)
Source, Georgia Stormwater Management Manual



Sand Filter Variations

➤ **Perimeter Sand Filters**



Figure PTP-01- 6 Perimeter Sand Filter

Source, Stormwater Managers Resource Center, [_____](#)



Figure PTP-01- 7 Perimeter Sand Filter

Showing pre-cast concrete form with 2 chambers

Source, Stormwater Managers Resource Center, [_____](#)



Sand Filter Variations

➤ **Perimeter Sand Filters (cont.)**

Perimeter sand filters are constructed just below grade with two enclosed parallel trench-like chambers. Typically, perimeter sand filters are installed along the perimeter of a parking lot for off-line treatment. The first chamber is a sedimentation chamber that also has a shallow permanent pool of water. The second chamber is a filtration chamber that contains the sand filter (depth 12 – 18 inches) as well as an underdrain system that discharges filtered runoff to the outflow location. The first and second chambers are separated by an overflow weir. Runoff from impervious areas enters the device via an inlet grate and first fills the sedimentation chamber. Once water levels in the sedimentation chamber reach the top of the overflow weir between the two chambers, flow spills over the weir and into the filtration chamber. The sand bed filters runoff, and runoff is then collected by the perforated pipe and gravel underdrain system for discharge to the outflow location. During storm conditions, runoff normally temporarily ponds in the two chambers until both chambers fill up to capacity. Once both chambers are filled to capacity, excess runoff is routed to a separate bypass drop inlet.

Perimeter sand filters consume a small amount of surface space, and are ideal for small impervious areas, particularly hot spot applications and retrofits. Perimeter sand filters are best suited for effective pollutant removal for drainage areas up to 2 acres. The perimeter sand filters should be constructed along the boundary, or perimeter, of an impervious area (i.e., a parking lot). See Figures PTP-01-8 through PTP-01-11 for typical perimeter sand filter schematics.

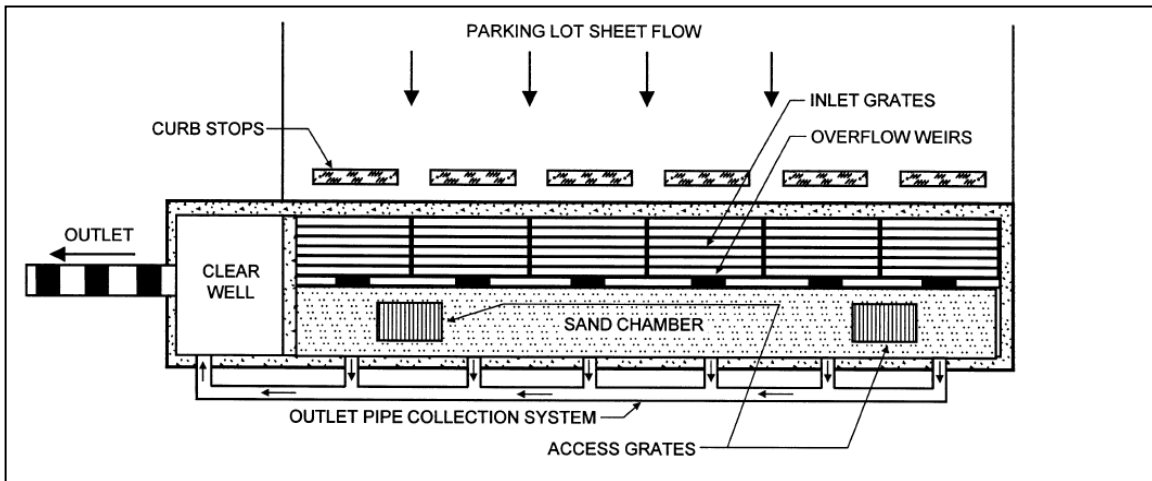

Figure PTP-01- 8 Perimeter Sand Filter
Source, Georgia Stormwater Management Manual



Sand Filter
Variations

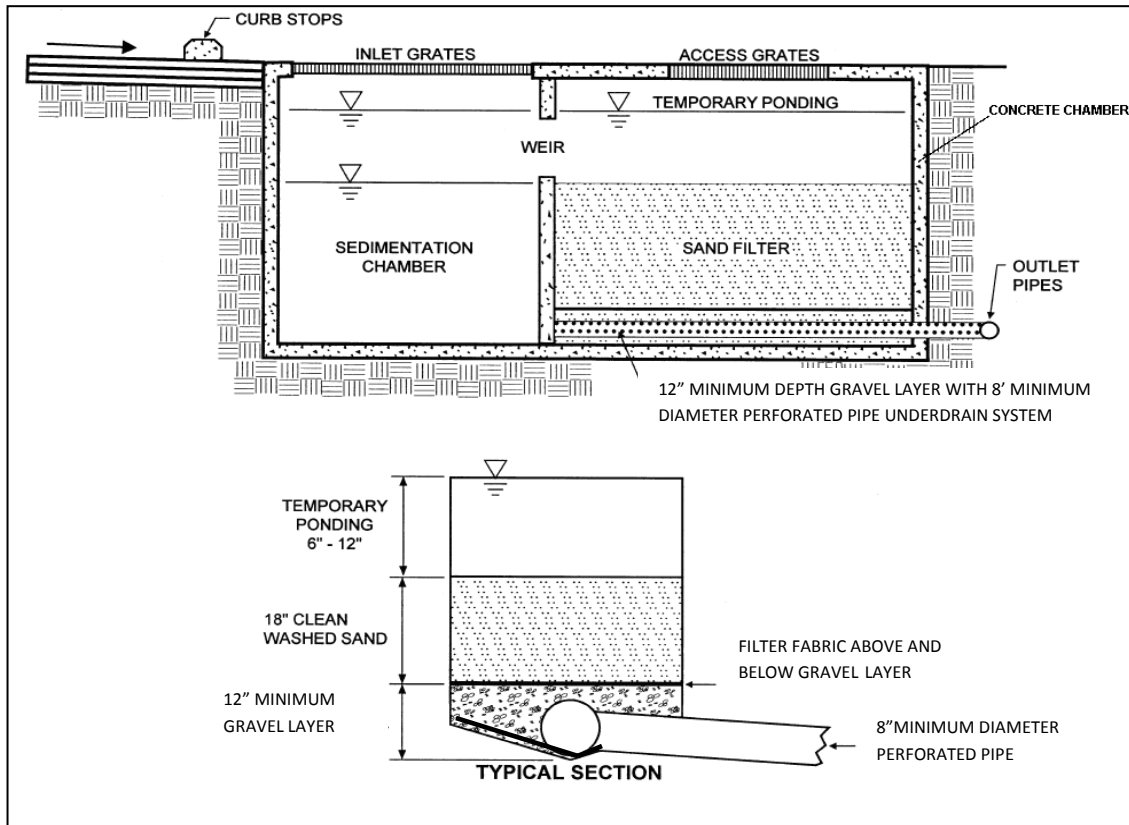
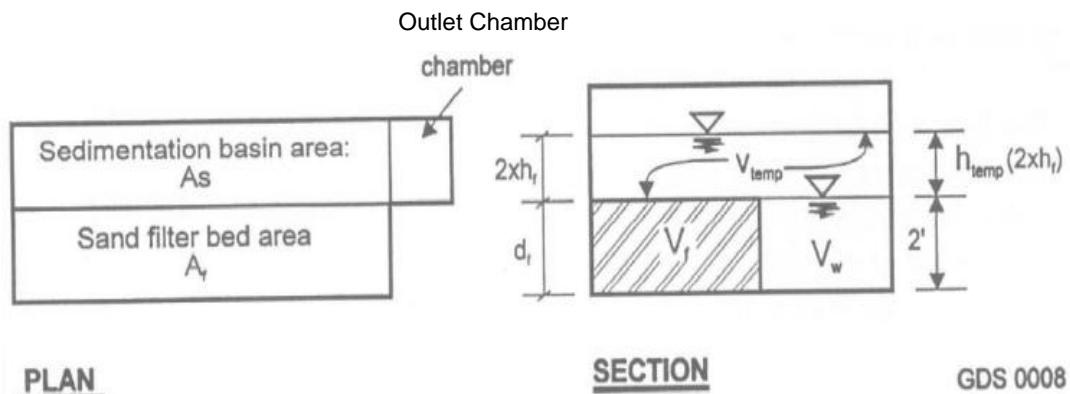

Figure PTP-01- 9 Perimeter Sand Filter (cross sectional view)
Source, Georgia Stormwater Management Manual



| | |
|---|--|
| V_w = Wet pool volume of the sedimentation basin | A_f = Surface area of the filter media |
| V_f = Volume of voids in the filter bed | h_s = Depth of water in the sedimentation basin |
| V_{temp} = Temporary volume stored above the filter bed | h_r = Average depth of water above the filter media ($\frac{1}{2} h_{temp}$) |
| A_s = Surface area of the sedimentation basin | d_f = Depth of the filter media |

Figure PTP-01- 10 Perimeter Sand Filter Chamber Design
Source, Georgia Stormwater Management Manual



Sand Filter Variations

➤ Perimeter Sand Filters (cont.)

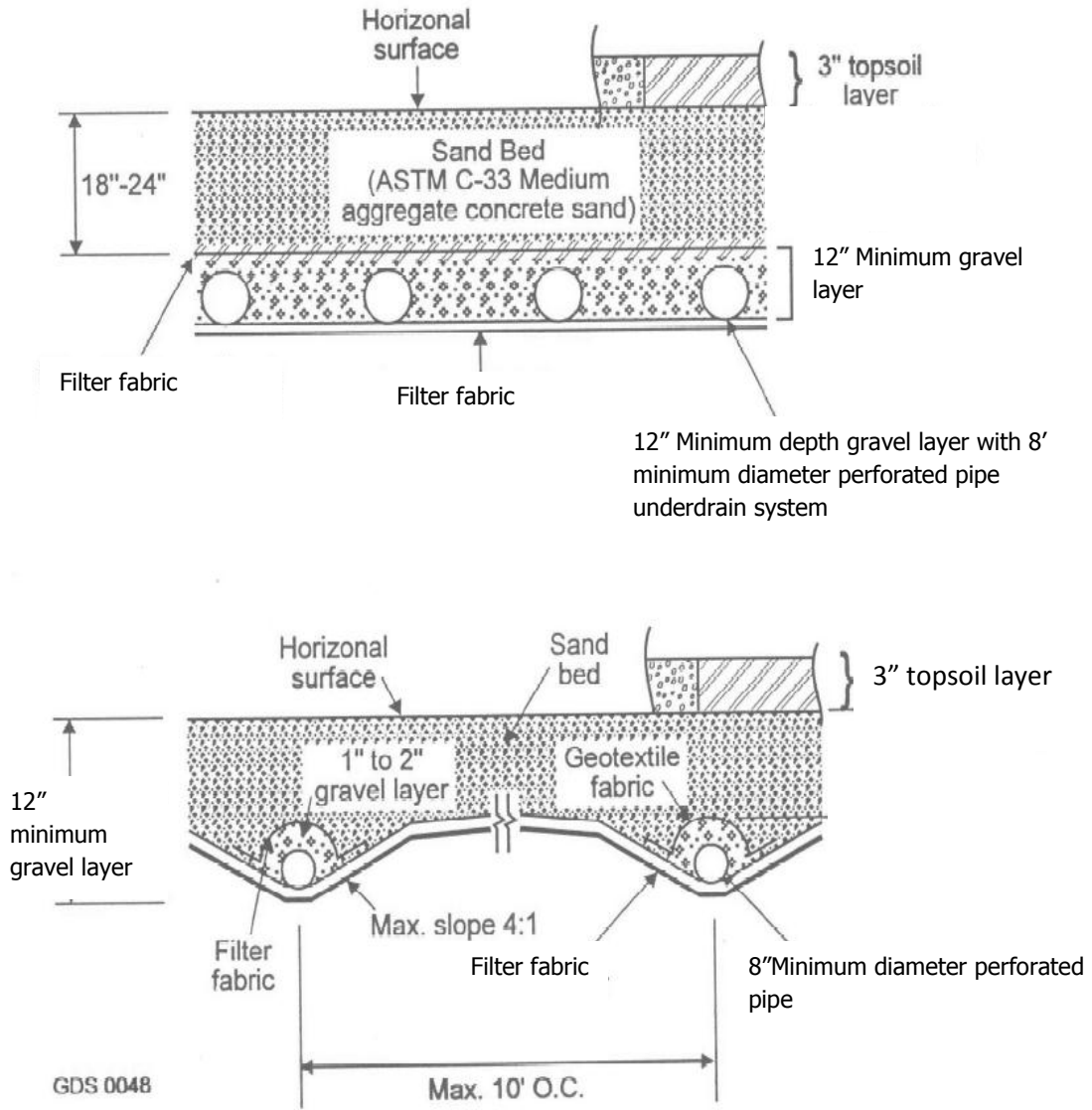

Figure PTP-01- 11

Source, Georgia Stormwater Manual



**Sand Filter
Variations**

➤ **Underground Sand Filters**



Figure PTP-01- 12 Underground Sand Filter
Source, University of Virginia Stormwater and Watershed Group

Underground sand filters are designed for applications with extreme space constraints or high density areas such as parking lots where a surface sand filter cannot be constructed due to space limitations. They are typically used as on-line systems for impervious areas of 1 acre or less. An underground sand filter should not be designed to treat a drainage area greater than 5 acres. Underground sand filters may be used to effectively remove pollutants for drainage areas up to 2 acres. One key consideration for underground sand filters is accessibility for inspection and maintenance. Access is often provided by manholes or grate openings.

This type of filtration system utilizes a three-chamber vault, where the first two chambers temporarily store and treat runoff, and the third chamber collects the filtered runoff. For a storm event, the water quality volume is temporarily stored in both of the first two chambers. When flows exceed the filter's capacity in the first two chambers, the overflows are diverted through an overflow weir to exit the filter.

Each of the underground sand filter chambers performs a separate function. The first chamber is known as a sedimentation chamber or a wet pool chamber. This first chamber provides pre-treatment with a wet pool as well as temporary runoff storage. The first chamber is connected to the second chamber by either a submerged wall or an inverted elbow. This connection between the first two chambers helps obstruct oil and floatables from passing from the first chamber into the second chamber. The second chamber is called the sand filter or filter bed chamber. The second chamber's filter bed depth should be between 18 to 24 inches. Permeable geotextiles or a gravel screen may be used to limit filter bed clogging. The second chamber also contains a perforated drain pipe to collect and pass the filtered runoff to the third chamber. The third chamber, or the overflow chamber, discharges the filtered runoff as well as any overflows to the outlet. See Figures PTP-01-13 and PTP-01-14 for schematics of a typical underground sand filter.



Sand Filter Variations

➤ Underground Sand Filters (cont.)

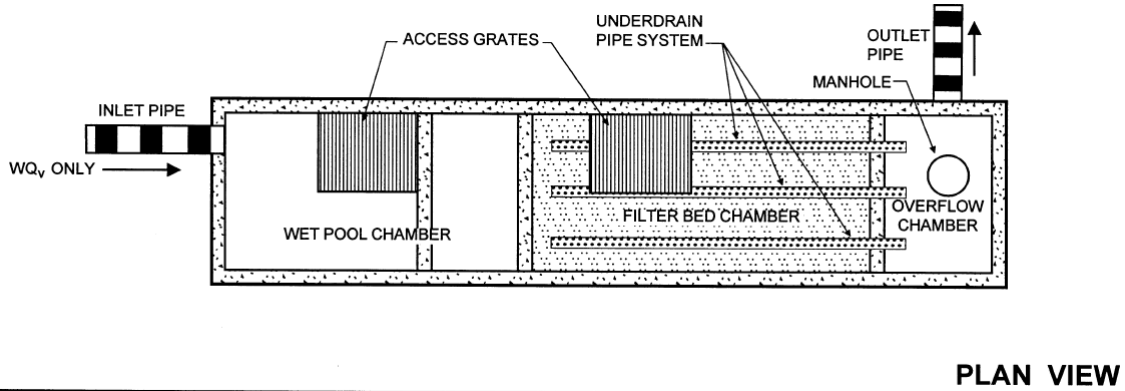

Figure PTP-01-13 Underground Sand Filter
Source, Georgia Stormwater Management Manual

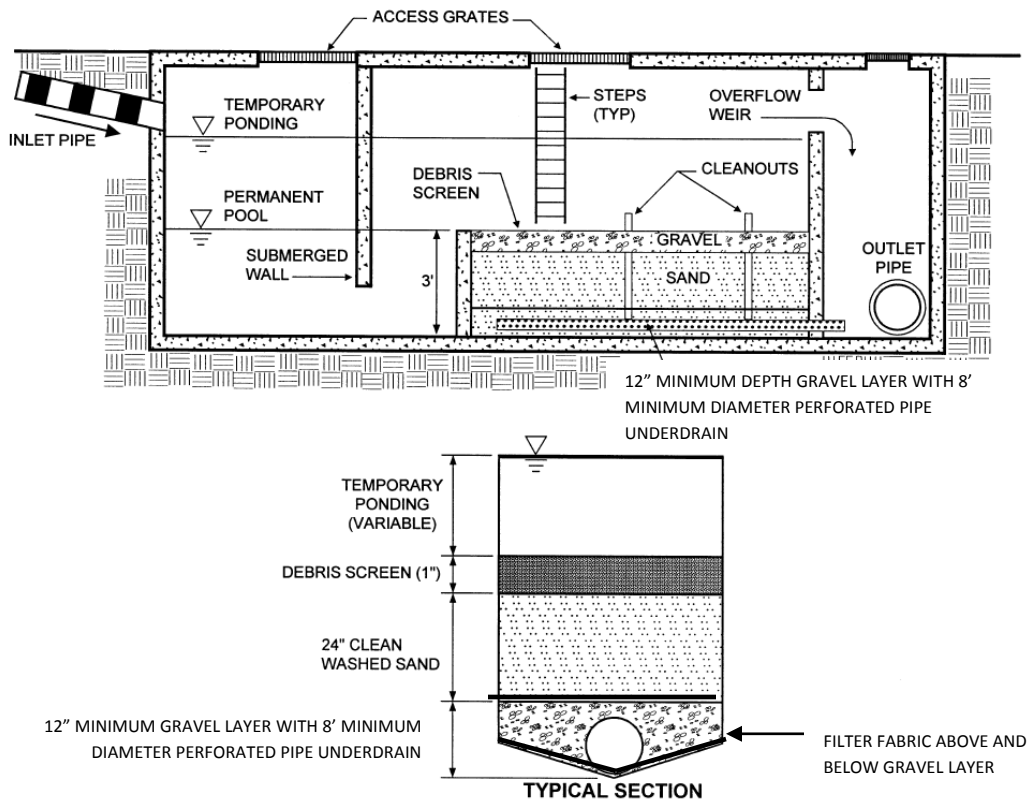

Figure PTP-01-14 Underground Sand Filter (cross sectional view)
Source, Georgia Stormwater Management Manual



Maintenance Maintenance Plan

A site-specific maintenance plan describing maintenance responsibilities shall be developed. that addresses the following items:

- Maintenance access for appropriate equipment, vehicles, and personnel.
- Operating instructions for drawdown valves, gates and removable weirs (if applicable)
- Vegetation maintenance schedule
- Inspection checklist
- Maintenance agreement between the facility owner and the City with these items:
 - Sediment removal from sedimentation chamber when sediment depth is $\frac{1}{2}$ of the total depth to the outlet, or is greater than 12 inches (whichever is less)
 - Clean and/or repair sediment chamber outlet devices if drawdown times exceed 48 hours
 - Trash and debris should be removed as necessary
 - Sediment accumulations exceeding one inch should be removed from the bed
 - If filtering capacity is substantially diminished (i.e., for surface filters, water ponds on filter surface for more than 48 hours, remove and replace the top three inches of filter media with same fresh media and acceptably dispose of removed material)
- Grass cover filters should be mowed as needed (maximum grass height of 12 inches)

Monthly

- Remove trash or debris from drainage area, inlets, outlets and filter system
- Check that drainage area is stabilized and mowed (with clippings removed), with measures in place to minimize oil/grease and sediment released to filter system
- Inspect the filter surface for clogging monthly and after storm events greater than one inch (sand filters – rake the first inch of sand)
- For pre-treatment chambers with a permanent water level (e.g., perimeter sand filter), check the pre-treatment chamber for leakage and for retention of the normal pool level

Quarterly/After Major Storm Events

- Monitor water level in sand filter chamber (underground sand filter)

Annually

- Check filter bed and sediment chamber sediment depths



Maintenance **Annually (continued)**

- Inspect concrete and grates (perimeter sand filters) for deterioration and damage
- Check inlets, outlets and overflow spillway for proper operation and for erosion
- Repair or replace any damaged structural parts
- Stabilize any eroded areas
- Look for signs of flow bypassing the facility (the exception is the expected flow bypassing for high flow events)
- Check for noticeable odors detected outside the facility

3-5 Years

- Remove and replace the top 2-5 inches of media. High sediment yield or high oil and grease may require more frequent media removal/replacement

As Needed

- Clean out sedimentation chamber when sediment depth reaches 12 inches (underground sand filter)
- Clean and/or repair sediment chamber outlet devices if drawdown times exceed 48 hours
- Remove accumulated oil and floatables from the sedimentation chamber (underground sand filter)
- For clogged or partially clogged sand beds (i.e., water ponds on filter surface for more than 48 hours), remove the top three inches of sand from the surface, till, or cultivate the bed, and replace with fresh sand meeting the appropriate design specifications
- Properly dispose of any material generated during maintenance activities.
- Grass cover filters should be mowed as needed (maximum grass height of 12 inches)
- Replace clogged filter fabric



**Inspection
Checklist**

All appropriate items should be checked on the inspection checklist. If an applicable item does not meet the condition on the checklist, maintenance and/or repairs should be implemented to correct the situation.

As Needed

- Accumulated oil and floatables were removed from the sedimentation chamber (underground sand filter)
- Filtration system (sand bed, filter fabric, etc.) is not clogged or partially clogged
- Sediment depth in sedimentation chamber is less than ½ of the total depth to the outlet or is less than 1.5 feet 12 inches (whichever is greater)
- Filter's drawdown times do not exceed 48 hours
- The top 2-5 inches of media material has been removed and replaced within the past 3-5 years (if the system has been operational for 3-5 years)

Monthly

- Contributing area, facility, inlets, and outlets are clear of debris
- Contributing area is stabilized and mowed, with clippings bagged or removed and with measures in place as needed to minimize oil/grease and sediment released to system
- For filters with grass cover, grass height is less than 12 inches
- Filter surface is not clogging – also inspect after moderate/major storm events (> 1")
- Activities in the drainage area minimize oil/grease and sediment entering the system
- Permanent water level is not present (for perimeter sand filter)
- For filtration systems utilizing a permanent pool in a pre-treatment chamber, the chamber or vault does not leak, and normal pool water surface elevation is retained

Quarterly

- For underground sand filters, water level in sand filter chamber is acceptable

Annually

- Filter bed is clean of sediment, and the sediment chamber contains no more than 6 inches or 50% depth of sediment, whichever is less (or 12 inches for underground sand filters)
- There are no eroded areas that require stabilization
- There were no signs of flow bypassing the filter (except for expected high flow bypass)
- No evidence of deterioration, spalling, or cracking is present on concrete
- Inspect grates, where applicable
- Structural parts are free of damage and do not need repair or replacement
- Flow is not bypassing the filtration system
- No noticeable odors are detected outside of the facility.



Design

Criteria

All sand filters:

- The drainage area size typically dictates the sand filter size, with a preferred drainage area between 0.5 – 2 acres. Maximum drainage area limits are as follows:
 - Surface sand filter maximum of 10 acres
 - Perimeter sand filter maximum of 2 acres
 - Underground sand filter maximum of 2 - 5 acres
- Sloped areas immediately adjacent to the sand filter system should be no greater than 5:1 (H:V) nor less than 1% to promote positive flow toward the system.
- The sand filter system surface slope should not exceed 1%, to promote even distribution of flow throughout the system.
- The sand filter system should be designed such that it is drained within 48 hours from the peak water level in the system.
- Most sand filters are configured off-line, so that flows greater than the water quality volume (WQ_v) capacity can be diverted downstream. The exception is underground sand filters, which are typically designed on-line.
- Sand filters require pre-treatment. Most sand filters will use a sediment chamber for pretreatment.
 - The recommended minimum length to width ratio for the sediment chamber is 2:1.
 - Inlet and outlet structures should be built at opposite ends of the sedimentation chamber.
 - The minimum wet pool volume required in the sedimentation chamber should be calculated using $V_w = A_s \times 3$ feet.
- Sand filters must include appropriate elevation differences and head considerations.
 - For most sand filters, the recommended elevation difference between the inflow and the outflow is between 4-6 feet.
 - For perimeter sand filters, the elevation difference may be 2-3 feet.
 - Sand filters typically require 2-6 feet of head.
- A minimum of 3 feet of separation is required between the sand filter bottom and seasonally saturated soils. A 5-foot separation is recommended between the sand filter bottom and seasonally saturated soils.
- During construction, disturbed areas draining to the sand filter should be identified and stabilized as soon as possible as they may clog the filter bed. Flow should not be directed into the sand filter until after impervious area construction is completed and pervious areas have established, dense, healthy vegetation.



Design
Criteria

All sand filters (cont'd):

- Safety considerations must be considered and included in the design.
 - Mosquito breeding risks should be reduced for surface systems by ensuring that the structure dewateres within 72 hours.
 - Fencing may be desirable or required to limit entry. Measures that are more than 5 feet deep require OSHA safe construction health and safety guidelines.
- Site access for maintenance should also be considered in the design process.
- For sand filters located in sensitive areas (i.e., potential stormwater hotspots), additional treatment practices are recommended for partial treatment during the winter when the filter bed may be frozen.
- The filtration system must be designed to temporarily hold a capacity equal to or greater than 75% of the water quality volume (WQ_v) of the system prior to filtration.

Surface sand filters:

- The sedimentation chamber must have a capacity to hold 25% of the water quality volume (WQ_v), and have a ratio of 2:1 (H:V).
- Required space is a function of available head at the site for surface filters.
- Grass covers for surface filters should use grasses suited for withstanding frequent periods of inundation and drought.
- Protect underground sand beds from trash accumulation by placing a wide mesh geotextile screen on the sand bed surface. This screen may be rolled up, removed, cleaned and reinstalled during maintenance.

Perimeter sand filters:

- The sedimentation chamber should be sized to accommodate at least 50% of the calculated WQ_v.
- For perimeter sand filters with grates, the grates should be heavy so that the grates are not easily removed.
- The permanent pool depth in the sedimentation chamber should consider factors such as mosquito control and maintenance requirements.

Underground sand filters:

- Underground filters have little or no surface space requirements except for access. No building structures should be located above underground filters.
- Underground sand filters would require entry by individuals with confined space entry training.



Design

Criteria

Underdrain system:

- Sand filters must use an underdrain/collection system to carry flow to another conveyance element. This system should contain a minimum 8-inch perforated PVC pipe surrounded by a 12-inch thick gravel layer. Increasing the diameter of the underdrain makes freezing less likely, and provides a greater capacity to drain standing water from the system.

Design

Components

- **Pre-treatment** – Pre-treatment areas function to capture and remove coarse sediment particles from runoff prior to runoff entering the treatment component. Incorporation of pre-treatment helps to reduce required maintenance for the treatment component and reduces the potential for filter clogging. These pre-treatment areas vary in name depending on the sand filter type used. For sand filters located in sensitive areas (i.e., potential stormwater hotspots), additional treatment practices are recommended for partial treatment during the winter when the filter bed may be frozen. Pre-treatment component information specific to the sand filter type are presented in the following bullet sections:
 - **Surface Sand Filters** – The sedimentation chamber must have a capacity to hold 25% of the water quality volume (WQ_v).
 - The chamber must also have a ratio of 2:1 (H:V) and have a minimum length to width ratio of 2:1.
 - The chamber inlet and outlet structures should be located at opposite ends of the chamber.
 - The minimum wet pool volume required in the sedimentation chamber should be calculated using $V_w = A_s \times 3$ feet.
 - **Perimeter Sand Filters** - The sedimentation chamber should be sized to accommodate at least 50% of the calculated WQ_v.
 - **Underground Sand Filters** – Underground filters have little or no surface space requirements except for access.
 - No building structures may be located above the underground filters.
 - Underground sand filters would require entry by individuals with confined space entry training.
- **Treatment** – The treatment areas house the sand filters, which remove pollutants.
 - **General Requirements** –
 - Sloped areas immediately adjacent to the sand filter system should be no greater than 5:1 (H:V) nor less than 1% to promote positive flow toward the system.
 - The sand filter system surface slope should not exceed 1%, to promote even distribution of flow throughout the system.
 - The sand filter system should be designed such that it is drained within 48 hours from the peak water level in the system.



**Design
Components**

- The filtration system must be designed to temporarily hold a capacity equal to or greater than 75% of the water quality volume (WQv) of the system prior to filtration.
 - For sand filters located in sensitive areas (i.e., potential stormwater hotspots), additional treatment practices are recommended for partial treatment during the winter when the filter bed may be frozen.
 - Required space is a function of available head at the site for surface filters. Except where discussed below for specific filter types, the recommended elevation difference between the inflow and the outflow is between 4-6 feet.
 - Use Darcy's law to size the filter bed area. The permeability coefficients (k) for different filter materials are shown below:
 - (l) Sand - 3.5 ft/day
 - The filter media for all sand filters should include a minimum layer depth of 18 inches of clean, washed, medium sand (ASTM C-33 concrete sand).
 - **Surface Sand Filters** – Grass covers for surface filters should use grasses suited for withstanding frequent periods of inundation and drought.
 - **Perimeter Sand Filters** -. For perimeter sand filters, the elevation difference may be 2-3 feet. The grates should be heavy so that the grates are not easily removed.
 - **Underground Sand Filters** – Place filter beds for underground filters below the frost line to prevent the filtering medium from freezing during the winter.
- **Underdrain/Collection System** – Sand filters must use an underdrain/collection system to carry flow to another conveyance element. This type of underdrain system is recommended for tight impermeable soils where infiltration is limited. Otherwise, refer to the guidance for “hot spot” areas discussed below.
- For areas that are known as potential stormwater “hot-spots” (e.g., gas stations, transfer sites, and transportation depots), the underdrain system must also include an impervious liner designed to reduce or eliminate the possibility of ground water contamination. This type of facility should consider how to address accidental spills. For instance, the underdrain discharge point can be blocked and the objectionable materials maybe siphoned through an observation well and safely contained.
 - The underdrains should be equipped with a minimum 8-inch perforated PVC pipe surrounded by a 12-inch thick gravel layer. Increasing the pipe diameter decreases the potential for freezing. The porous gravel layer promotes drainage and is less susceptible to frost heaving than media with smaller particle size.
 - The gravel shall be washed and 1-1/2” in size or clean, washed aggregate at a diameter no greater than 3.5 inches and no less than 1.5 inches. The porous gravel layer prevents standing water in the system by promoting drainage.



**Design
Components**

- The minimum slope of the underdrain system is $\frac{1}{8}$ -inch per foot (1% slope)
- A minimum of 3 feet of separation is required between the bottom of the sand filter and seasonally saturated soils.
- A permeable filter fabric must be placed between the gravel layer and the filter bed material. The filter fabric does not need to extend to the side walls. The filter fabric may be installed horizontally above the gravel blanket, extending just 1-2 feet on either side of the underdrain pipe below.
- Do **not** wrap the under-drain with filter fabric.
- A permeable filter fabric must also be placed between the underdrain gravel layer (beneath the perforated pipe) and the native soil material under the filter system. Note that permeable fabric will allow potential infiltration into the native soil material beneath the filter system. For scenarios where this infiltration is not desirable, use an impermeable liner as described for “hot spot” land use areas.
- Pipe perforations must be sized approximately $\frac{3}{8}$ inch in diameter spaced at 6-inch intervals on center. At a minimum, 4 holes per row should be used, and pipe grade placement should be at least 0.5%. Pipes should be spaced no more than 10 feet on center.



**Design
Procedure**

Step 1 – Make a preliminary judgment as to whether site conditions are appropriate for the use of a sand filter system, and identify the sand filter type and function in the overall treatment system. This includes performing an initial suitability screening for the site.

- Consider basic issues for initial suitability screening, including:
 - Site drainage area
 - Site topography and slopes
 - Soil type and infiltration capacity
 - Depth to water table and bedrock
 - Site location/minimum setbacks
 - Presence of active karst features
 - % Impervious Area
 - Intermittent Flow
 - Sufficient Flow Elevation Difference
 - Proposed development use (Is development commercial, industrial, or institutional?)
- Determine how the sand filter system will fit into the overall stormwater treatment system.
 - Decide whether the sand filter system will be the only BMP to be employed, or if there are other BMPs addressing some of the treatment requirements.
 - Decide where on the site the sand filter system is most likely to be located.

Step 2 – Confirm design criteria, site constraints, and applicability.

- Determine the design criteria that will be used.
- Determine any constraints the site will place on the sand filter system such as:
 - High pervious area in the drainage area
 - Limited amount of surface area available for treatment
 - High water table
- Determine the TSS reduction provided, using the equations below for weighted TSS reduction, $TSS_{weighted}$, and TSS treatment train, TSS_{train} . The minimum TSS reduction required for the site is 80% and can be weighted for the site.

$$\%TSS_{weighted} = \frac{\sum_n^1 (TSS_1 A_1 + TSS_2 A_2 + \dots + TSS_n A_n)}{\sum_n^1 (A_1 + A_2 + \dots + A_n)}$$

Where runoff is treated by two or more BMPs in series, the TSS reduction provided is calculated with the following equation for a treatment train:

$$TSS_{train} = A + B - \frac{(A \times B)}{100}$$



City of Berea
Stormwater Manual Best Management Practices

Design Procedure

Where A is the TSS reduction provided by the first BMP and B is the TSS reduction provided by the next BMP.

Step 3 –Select a sand filter type based on the initial suitability screening, design criteria, site constraints and applicability. Perform field verification of site suitability.

- The field verification should be conducted by a qualified geotechnical professional.

Determine the depth to groundwater. A minimum of 3 feet of separation between the bottom of the sand filter system and seasonally saturated soils (or from bedrock) is required (5 feet of separation is recommended).

Step 4 – Compute runoff control volumes and peak flows.

- Calculate the Water Quality Volume (WQV).

$$WQ_v = [P R_v(A)]/12$$

Where:

P = 1.1 inches

RV = 0.05 + 0.009(I), where I is the percent impervious

cover A = the area of imperviousness, (acres)

- The volume of voids in the sand filter’s underdrain system may be subtracted from the WQ_v. The volume of voids should be estimated at 35% of the total volume of the underdrain system.
- Calculate the peak flow for the Water Quality Volume (Q_{wq}), 25 yr peak runoff rate (QP25), and the 100 yr peak runoff rate (QP100). Refer Appendix B for more information on QP25 and QP100.
 - Determine the peak flow for Water Quality Volume (Q_{wq}).

$$Q_{wq} = C \times IWQ \times A$$

Where:

Q_{wq} = the water quality volume peak flow, (cfs)

C = the runoff coefficient

IWQ = the rainfall intensity, 2.45 in/hr

A= the area of imperviousness, (acres)

The common reference used for runoff coefficients is Design and Construction of Sanitary and Storm Sewers, American Society of Civil Engineers and the Water Pollution Control Federation, 1969.

Note that designs for managing QP25 and QP100 must be consistent with the City-County Planning Commission requirements and are not addressed in this manual. Information about these requirements is contained in Section 2.4.7.



City of Berea
Stormwater Manual Best Management
Practices

Design
Procedure

Note: Steps 5-12 are iterative

Step 5 – Size flow diversion structure, if needed.

- A flow regulator or flow splitter should be used to divert WQV into the sand filter system.
- The most common approach used is setting a bypass weir within the diversion based on the elevation of the water quality volume within the system.
- Size low flow orifice, weir or other device to pass WQV.

STEP 6 – Size the filtration basin (sand filter) chamber..

- The filter area is sized using the following equation (based on Darcy’s Law):

$$A_f = (WQ_v) (d_f) / [(k) (h_f + d_f) (t_f)]$$

Where:

A_f = surface area of filter bed, (ft²)

WQ_v = Water Quality Volume, (ft³)

NOTE: The volume of voids in the sand filter’s underdrain system may be subtracted from the WQ_v. The volume of voids should be estimated at 35% of the total volume of the underdrain system.

d_f = filter bed depth, (ft) - minimum depth is 18 inches, maximum depth is

24 inches

k = coefficient of permeability of filter media, (ft/day) use 3.5 ft/day for sand

h_f = average height of water above filter bed, (ft)

t_f = design filter bed drain time, (days) - 2 days or 48 hours maximum

- Use these calculations to set the preliminary dimensions for the filtration basin chamber. See the Design Criteria for filter media specifications.

STEP 7 – Size the sedimentation chamber.

- Sedimentation chamber size is based on volume requirements, maximum ponding depth and the particle settling ability.
- **Surface sand filter:** The sedimentation chamber should be sized to at least 25% of the computed WQ_v and have a length-to-width ratio of 2:1. The Camp-Hazen equation is used to compute the required surface area:

$$A_s = - (Q_o/w) * \ln (1-E)$$

Where:

A_s = sedimentation basin surface area (ft²)

Q_o = rate of outflow = the WQ_v over a 24-hour period

w = particle settling velocity (ft/sec)

E = trap efficiency



Design Procedure

Assuming:

- E = 90% sediment trap efficiency (0.9)
- w = particle settling velocity (ft/sec) = 0.0004 ft/sec for imperviousness < 75%
- w = particle settling velocity (ft/sec) = 0.0033 ft/sec for imperviousness ≥ 75%
- average of 24 hour holding period

Then:

$$A_s = (0.066) (WQ_v) \text{ ft}^2 \text{ for } I < 75\%$$

$$A_s = (0.0081) (WQ_v) \text{ ft}^2 \text{ for } I \geq 75\%$$

Where:

I = percent impervious

Perimeter sand filter:

The sedimentation chamber should be sized to hold at least 50% of the computed WQ_v . Use same approach as for surface sand filter.

- Use Table PTP-01-1 to set the preliminary surface area for the sedimentation chamber (settling chamber). Select the filter type, drainage area imperviousness and the maximum ponding depth.

Table PTP-01- 1 Sedimentation Chamber (Settling Chamber) Surface Area

| Sand Filter | | Maximum Ponding Depth (feet) | |
|-----------------------|------|------------------------------|------------------------|
| | | <4 | 4-10 |
| Impervious | ≥75% | $(0.25*WQ_v)/D_{max}$ | $(0.25*WQ_v)/D_{max}$ |
| | <75% | $(0.25*WQ_v)/D_{max}$ | $(0.066*WQ_v)/D_{max}$ |
| Perimeter Sand Filter | | Maximum Ponding Depth (feet) | |
| | | <7.5 | 8-10 |
| Impervious | ≥75% | $(0.5*WQ_v)/D_{max}$ | $(0.5*WQ_v)/D_{max}$ |
| | <75% | $(0.5*WQ_v)/D_{max}$ | $(0.066*WQ_v)/D_{max}$ |

STEP 8 – Compute V_{min} (the minimum volume that can be stored within the filtration chamber).

$$V_{min} = 0.75 * WQ_v$$

STEP 9 – Compute storage volumes within the entire facility as well as the sedimentation chamber orifice size.

Surface sand filter:

$$V_{min} = 0.75 WQ_v = V_s + V_f + V_{f-temp}$$

- V_f = water volume within filter bed/gravel/pipe

$V_f = A_f * d_f * n$, where:

- n = porosity = 0.35 for filter material including gravel as specified in Design Criteria and Design Components



Design Procedure

- V_{f-temp} = temporary storage volume above the filter bed

$$V_{f-temp} = 2 * h_f * A_f$$

- V_s = volume within sediment chamber

$$V_s = V_{min} - V_f - V_{f-temp}$$

- h_s = height in sedimentation chamber

$$h_s = V_s / A_s$$

- Ensure that h_s and h_f fit the available head and that the other dimensions still fit. Make iterative changes as necessary in design until all site dimensions fit.
- Size the orifice that carries flow from the sedimentation chamber to the filter chamber so that V_s is released within 24 hours at an average release rate with $0.5 h_s$ as the average head.
- Design the outlet structure with perforations that allow for a safety factor of 10.
- Size distribution chamber to spread flow over filtration media – level spreader weir or orifices.

Perimeter sand filter:

- V_f = water volume within filter bed/gravel/pipe

$$V_f = A_f * d_f * n$$

Where: n = porosity = 0.35 for filter material including gravel as specified in Design Criteria and Design Components

- V_w = wet pool storage volume

$$V_w = A_s * \text{wet pool depth}$$

- Minimum wet pool depth = 2 feet

- V_{f-temp} = temporary storage

$$\text{volume } V_{f-temp} = V_{min} - (V_f + V_w)$$

- h_{temp} = temporary storage

$$\text{height } h_{temp} = V_{f-temp} / (A_f +$$



City of Berea Stormwater Manual Best Management Practices

Design Procedure

- Ensure $h_{temp} \geq 2 * h_f$, otherwise decrease h_f and re-compute. Ensure that the dimensions fit the available head and area. Change as necessary in design iterations until all site dimensions fit.
- Size distribution slots from sediment chamber to filter chamber. The elevation and size of these distribution slots should consider the desired permanent pool elevation as well as factors such as mosquito control and maintenance requirements. A minimum pool depth of 2 feet should be maintained in the sediment chamber.

STEP 10 – Design inlets, pre-treatment facilities, underdrain system and outlet structures according to Design Criteria and Design Components.

- Pre-treatment of runoff is provided by the sedimentation chamber. Surface sand filter inlets should be provided with energy dissipaters. Sedimentation chamber exit velocities must be non-erosive.
- The outlet pipe should connect the facility's underdrain system with the facility's discharge location. Outlet protection is not generally necessary due to the slow rate of filtration. The exceptions are that emergency overflows and spillways may require outlet protection.

Surface sand filters:

- The surface sand filter must include an emergency or bypass spillway that will safely pass flows that exceed the design storm flows.
- The emergency spillway location should be sited away from downstream buildings and structures that could be impacted by the spillway discharge.
- The surface sand filter inlets should include energy dissipaters.
- This spillway prevents the filter water levels from overtopping the embankment and causing structural damage.

STEP 11 – Compute the overflow weir sizes.

Surface sand filters:

- Size overflow weir at elevation h_s in sedimentation chamber (above perforated stand pipe) to handle surcharge of flow through filter system from 25-year storm.
- Plan inlet protection for overflow from sedimentation chamber.
- Size the overflow weir at elevation h_f in filtration chamber (above perforated stand pipe) to handle surcharge of flow through filter system from 25-year storm.

Perimeter sand filter:

- Size the overflow weir at the end of the sedimentation chamber to handle excess inflow, set at WQ_v elevation.

STEP 12 - Check volume, peak discharge rates and period of inundation against any applicable state, local and other requirements.

- Water quality volume (WQ_v) - If the filtration system does not meet the requirement to treat the WQ_v , the sand filter's storage volume must be increased or the excess part of the WQ_v must be treated with another BMP (either upstream or downstream).



City of Berea
Stormwater Manual Best Management Practices

Design Procedure

- The sand filter must be able to discharge through the filter media in no more than 48 hours. Any additional flows that cannot be filtered within 48 hours should be routed to bypass the system to a stabilized discharge location.
- If the sand filter does not meet the period of inundation requirements, one approach to meet the inundation requirement is to increase the filter surface area (decrease the height of water above the filter bed). Another approach is to add one or more additional BMPs that reduce the portion of the WQ_v treated by the sand filter, which also changes the water level range for the sand filter.
- The 48-hour window considers the following factors: wet-dry cycling between rain events, unsuitable mosquito breeding habitat, suitable conditions for vegetation (where applicable), aerobic conditions and storage for back-to-back precipitation events.

STEP 13 – Prepare Vegetation and Landscaping Plan

- All sites must include plan information that includes completing impervious area construction and establishing dense and healthy vegetation for pervious area before stormwater is introduced into the sand filter.
- For surface filters with vegetation and organic filters, a Vegetation and Landscaping Plan should be prepared. The landscaping plan should address how the filter surface will be stabilized and how vegetation will be established. The vegetative cover must be able to withstand frequent periods of inundation and drought.

STEP 14 – Prepare operations and maintenance plan

Prepare the sand filter’s operations and maintenance plan based on the guidance given in the Maintenance Section.

STEP 15 – Complete the Design Summary Table

| Design Parameter | Required Size | Actual Size |
|---------------------------|---------------|-------------|
| Sand Filter Type: | | |
| WQ _v : | | |
| A _f : | | |
| Filtration Basin (LxW) | | |
| A _s : | | |
| Sedimentation Basin (LxW) | | |



**City of Berea
Stormwater Manual Best Management Practices**

Example Design



Figure PTP-01- 18 Sand Filter Design Example Site Plan.

Proposed development of an undeveloped site into an office building and associated parking.

Table PTP-01- 2 Sand Filter Design Example Site Base information.

| | | |
|--|---|------------|
| <p>Base Data Site Area = 3.54 ac Total drainage = 5.0 ac Soils Type "C"</p> | <p>Hydrologic Data</p> | |
| | Pre | Post |
| <p>Pre-Development Impervious Area = 0 ac; or I = 0% Meadow (CN = 71)</p> | CN | 71 89 |
| <p>Post-Development Impervious Area = 1.72 ac; or I = 1.72/3.54 = 49% Open Space, Fair (CN = 79) Paved parking lots, roofs, driveways, etc. (CN =98)</p> | <p>WQ_v Depth = 1.1 in</p> | |
| | <p>Precipitation</p> | |
| | I _{wq} | 2.45 in/hr |
| | 2yr, 24hr | 3.54 in |
| | 25yr, 24hr | 5.88 in |
| | 100yr, 24hr | 7.43 in |



City of Berea Stormwater Manual Best Management Practices

Example Design

This example focuses on the design of perimeter sand filter facilities to meet the water quality treatment requirements of the site. Peak flow reduction is not addressed in this example other than quantification of preliminary storage volume and peak discharge requirements. In general, the primary function of sand filters is to provide water quality treatment and not large storm attenuation. As such, flows in excess of the water quality volume typically bypass the facility or pass through the facility. Where quantity control is required, the bypassed flows can be routed to conventional detention pond (or some other facility such as underground storage vaults).

Problem: Design a post-construction stormwater water quality treatment plan for this site. A dry detention pond will be constructed to meet the required detention standards and will provide 60% TSS reduction for the site. The total drainage area to the pond is 5 acres. Try designing one or more perimeter sand filter systems in or near the parking areas in addition to the dry detention pond to achieve the required 80% TSS reduction.

Step 1 – Make a preliminary judgment as to whether site conditions are appropriate for the use of a sand filter system, and identify the sand filter type and function in the overall treatment system. This includes performing an initial suitability screening for the site.

- Consider basic issues for initial suitability screening, including:
 - The site has type “C” soils
 - There are no minimum setbacks
 - There are active karst areas on the site. The sand filter systems will not be located close to the sinkhole.
 - The total drainage to the detention pond is 5 acres.
 - The site’s topography, slopes, flow elevation difference and depth to water table and bedrock will support installation of sand filter systems away from active karst areas.
 - The percentage of impervious area is 49%.
 - The proposed development is a commercial office building with associated parking.
- Determine how the sand filter system will fit into the overall stormwater treatment system.
- The proposed sand filter systems will be part of a treatment train for TSS removal. A dry detention pond will be constructed to meet the required detention standards and will provide 60% TSS reduction for the site. The perimeter sand filters provide 80% TSS reduction when used as a single BMP. Try 2 sand filters:
 - The desired sand filter systems are perimeter sand filters. These units may be located under parking areas.
 - Try 2 sand filters, as noted above.
 - Sand filter 1 – 1.02 acres drainage
 - Sand filter 2 – 0.7 acres drainage
 - The treated water quality volume will be collected by an underdrain system and routed to the dry pond located in the northwest corner of the site for water quantity control. Flows greater than the water quality volume will bypass the perimeter sand filter systems and be routed to the dry pond for water quantity control and final polishing prior to discharging.



Example Design

Figure PTP-01-19 Sand Filter Design Example Impervious Drainage Areas and Filter Locations.

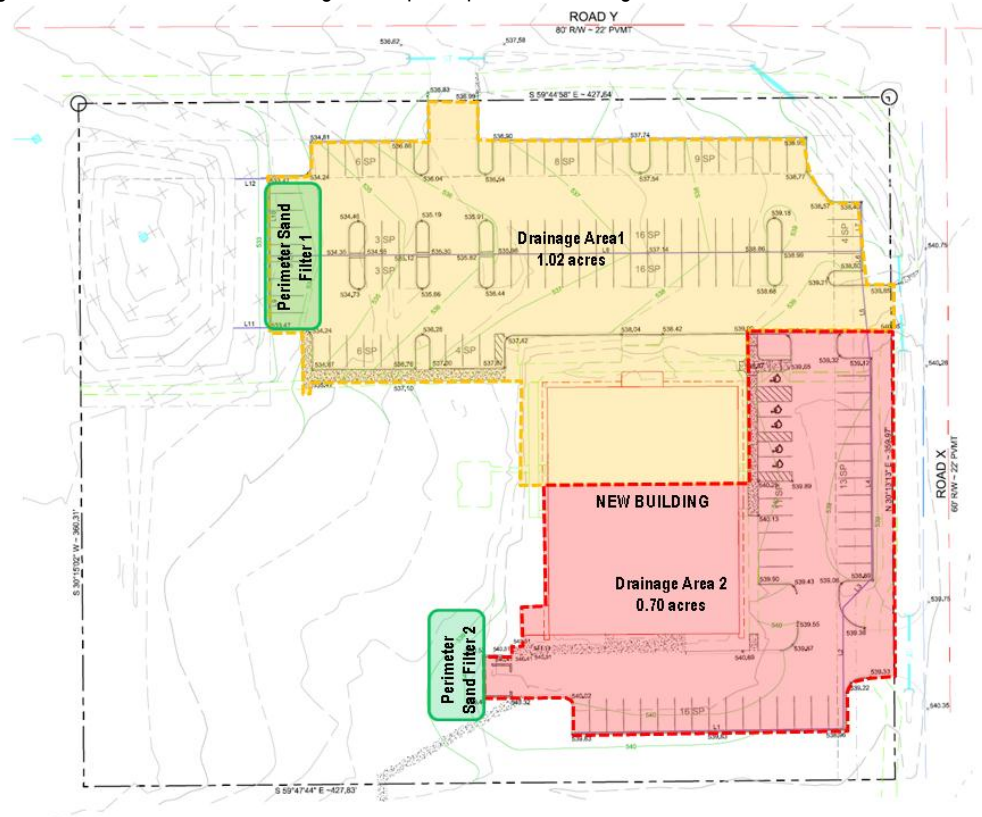

Step 2 – Confirm design criteria, site constraints, and applicability.

- The following minimum criteria will be used in the design.
 - The desired sand filter bed depth is 18 inches (1.5 feet).
 - Maximum 36 hour drain time from peak water level
 - Minimum 8-inch diameter underdrain enveloped in a 12-inch gravel layer
 - Minimum 3 foot separation from bottom to seasonally saturated soils
 - The percentage of pervious area and the percentage of impervious area in the contributing drainage area are nearly equal (49% impervious, 51% pervious).
 - The contributing drainage areas to each sand filter do not include large amounts of pervious area (i.e., drainage from pervious areas is routed around the contributing areas to the sand filters). This approach reduces the potential for clogging the sand filters.



City of Berea
Stormwater Manual Best Management Practices

Example Design

- **TSS removal** – The required TSS removal is a minimum of 80% reduction for average annual post-development load. All site areas drain toward the dry detention pond. Impervious site areas drain through the two perimeter sand filters en route to the dry detention pond. The total impervious area for this site is 1.72 acres. The %TSS removal is calculated using a treatment train for each of the impervious areas to show the combined effects of both the sand filters and the dry detention pond.

$$\%TSS = \frac{80 + 60 - (80 \times 60)}{100}$$

%TSS = 92% ✓

Therefore, the combination of two perimeter sand filters with the dry detention basin does meet the requirement for at least 80% TSS removal.

Step 3 – Select a sand filter type based on the initial suitability screening, design criteria, site constraints and applicability. Perform field verification of site suitability.

- The site geotechnical investigation showed that both the northwest and the south potential perimeter sand filter locations were suitable for installing sand filters.
- The soil borings indicated that the underlying soils in the vicinity of the sand filter locations had limited infiltration capacity and that the high water elevation was a minimum of 8 feet or more below the parking lot at both the northwest and south locations. This depth to the water table elevation is sufficient to maintain the minimum 3-foot separation between the bottom of the sand filter and the high water elevation.
- No impermeable layers/lenses or bedrock was encountered during the geotechnical field evaluation of the site.
- The site has a sinkhole in the location where the dry detention is proposed. The throat will be improved and used as the primary spillway for the detention pond.

Step 4 – Compute runoff control volumes and peak flows.

- Calculate the Water Quality Volume (WQ_v). This WQ_v calculation will be performed using each of the two contributing areas to allow individual sand filter sizing.

Sand Filter 1:

$$WQ_v = [(P R_v)(A)]/12$$

Where:

P = 1.1 inches

R_v = 0.05 + 0.009(I)

I = 49

R_v = 0.05 + 0.009(49) = 0.491

A₁ = 1.02 acres

$$WQ_{v1} = (1.1\text{in} \times 0.491 \times 1.02\text{ac})/12 = 0.046 \text{ acre-ft} = 2000 \text{ ft}^3$$



Example Design

FIRST ITERATION:

Step 5 – Size flow diversion structure, if needed.

- Since the perimeter filter system is a subsurface system, flows in excess of WQ_v will bypass the perimeter sand filter grates during higher runoff events. However, bypassing will not occur until the total volume, WQ_v , has been captured by the treatment mechanism of the sand filter. A separate drop inlet will be added beyond each perimeter sand filter system to convey runoff from these higher flow events to the dry detention pond once the perimeter sand filter reached maximum capacity.

STEP 6 – Size the filtration basin (sand filter) chamber.

- The filter area is sized using the following equation (based on Darcy’s Law):

$$A_f = (WQ_v) (d_f) / [(k) (h_f + d_f) (t_f)]$$

Where:

A_f = surface area of filter bed, (ft²)

NOTE: The volume of voids in the sand filter’s underdrain system may be subtracted from the WQ_v . The volume of voids should be estimated at 35% of the total volume of the underdrain system. For the first design iteration, the volume of voids for the underdrain system is not included. However, the underdrain system’s volume of voids will be subtracted from WQ_v in subsequent iterations.

d_f = filter bed depth, (ft) - minimum depth is 18 inches, maximum depth is 24 inches

k = 3.5, coefficient of permeability of filter media, (ft/day)

h_f = average height of water above filter bed, (ft)

t_f = design filter bed drain time, (days) - 2 days or 48 hours maximum

Sand Filter 1:

$$WQ_{v1} = 2000 \text{ ft}^3$$

$$d_f = 18 \text{ inches} = 1.5 \text{ feet}$$

$$k = 3.5 \text{ ft/day}$$

h_f = average height of water above filter bed, (ft)

Assume $h_{max} = 2$ feet for this site. Therefore, $h_f = \frac{1}{2} h_{max} = 1$ feet

$$t_f = 1.5 \text{ days}$$

$$A_{f1} = (2000 \text{ ft}^3) (1.5 \text{ feet}) / [(3.5 \text{ ft/day}) (1 \text{ foot} + 1.5 \text{ feet}) (1.5 \text{ days})] = 228.6 \text{ ft}^2$$

Round up to the nearest square foot to size for minimum surface area of filter bed of 229 ft².



City of Berea Stormwater Manual Best Management Practices

Example Design

Sand Filter 2:

$$WQ_{v2} = 1373 \text{ ft}^3$$

Assume $h_{\max} = 2$ feet for this site. Therefore, $h_f = \frac{1}{2} h_{\max} = 1$ feet

$$t_f = 1.5 \text{ days}$$

$$A_{f2} = (1373 \text{ ft}^3) (1.5 \text{ feet}) / [(3.5 \text{ ft/day}) (1 \text{ feet} + 1.5 \text{ feet}) (1.5 \text{ days})] = 156.9 \text{ ft}^2$$

Round up to the nearest square foot to size for minimum surface area of filter bed of 157 ft².

- Use these calculations to set the preliminary dimensions for the filtration basin chamber. See the Design Criteria for filter media specifications.

Sand Filter 1:

Set the filtration basin chamber at 46 ft x 5ft

Sizing took into consideration minimum surface area requirements and the site's configuration.

$$A_{r1} = 230 \text{ ft}^2 \checkmark$$

Sand Filter 2:

Set the filtration basin chamber at 20 ft x 8 ft

The location for Sand Filter 2 is more limited by site constraints such that the maximum filter length would be 20 feet.

$$A_{r2} = 160 \text{ ft}^2 \checkmark$$



Example Design

STEP 7 – Size the sedimentation chamber.

- For a perimeter sand filter, the sedimentation chamber should be sized to at least 50% of the computed WQ_v . The sedimentation chamber will be sized using an approach similar to that used for a surface sand filter.
- Table PTP 01-01 was used to set the preliminary surface area for the sedimentation chamber (settling chamber). The desired maximum ponding depth (D_{max}) used was 3 feet. The site's percentage of impervious area is 49%. A cross-section view for both sand filters is shown below.

Sand Filter 1:

$$A_{s1} = \text{Surface Area of Sedimentation Chamber} = (0.5 * WQ_{v1}) / D_{max} = (0.5 * 2000 \text{ ft}^3) / 3 \text{ feet}$$

$$A_{s1} = 334 \text{ ft}^2 \checkmark$$

- For the sedimentation chamber, the preliminary dimensions will use the same length (46 feet) used for the filter chamber's preliminary dimensions. This would require that the sedimentation chamber's width be at least 8 feet to achieve the surface area calculated above. Using the preliminary dimensions, A_{s1} becomes 46 feet x 8 feet = 368 ft^2 , and this value will be used for A_s in the subsequent calculations for the first iteration

Sand Filter 2:

$$A_{s2} = \text{Surface Area of Sedimentation Chamber} = (0.5 * WQ_{v2}) / D_{max} = (0.5 * 1373 \text{ ft}^3) / 3 \text{ feet}$$

$$A_{s2} = 229 \text{ ft}^2 \checkmark$$

- For the sedimentation chamber, the preliminary dimensions will use the same length (20 feet) used for the filter chamber's preliminary dimensions. This would require that the sedimentation chamber's width be at least 12 feet to achieve the surface area calculated above. Using the preliminary dimensions, A_{s2} becomes 20 feet x 12 feet = 240 ft^2 , and this value will be used for A_s in the subsequent calculations for the first iteration

STEP 8 – Compute V_{min} (the minimum volume that can be stored within the filtration chamber).

Sand Filter 1:

$$V_{min1} = 0.75 * WQ_{v1} = 0.75 * 2000 \text{ ft}^3 = 1500 \text{ ft}^3$$

Sand Filter 2:

$$V_{min2} = 0.75 * WQ_{v2} = 0.75 * 1373 \text{ ft}^3 = 1030 \text{ ft}^3$$



City of Berea
Stormwater Manual Best Management Practices

Example Design

Figure PTP-01-20 Sand Filter Design Example Cross Sectional View.

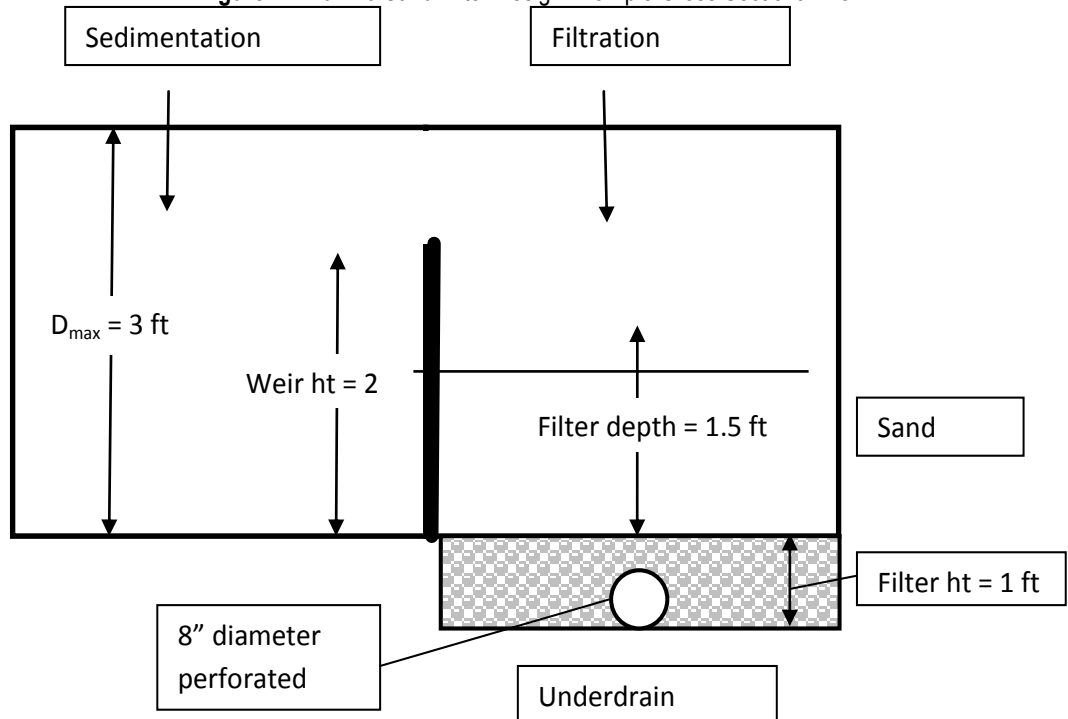

STEP 9 Compute storage volumes within the entire facility as well as the sedimentation chamber orifice size.

- Where: n = porosity = 0.35 for filter material including gravel as specified in Design Criteria and Design Components
- The filter layer depth (d_r) is the minimum depth of 1.5 ft.
- The minimum wet pool depth is 2 feet. For this design example, use the 2-foot minimum depth.

Sand Filter 1:

- Compute V_{f1} = water volume within filter bed/gravel/pipe = $A_{f1} * d_f * n$

$$V_{f1} = 230 \text{ ft}^2 * 1.5 \text{ ft} * 0.35 = 120.75 \text{ ft}^3$$

- Compute V_{w1} = wet pool storage volume = $A_{r1} * \text{wet pool depth}$

$$V_{w1} = 230 \text{ ft}^2 * 2 \text{ feet} = 460 \text{ ft}^3$$



City of Berea Stormwater Manual Best Management Practices

Example Design

- Compute V_{temp1} = temporary storage volume for Sand Filter 1 = $V_{\text{min1}} - (V_{\text{f1}} + V_{\text{w1}})$

$$V_{\text{temp1}} = 1500 \text{ ft}^3 - (120.75 \text{ ft}^3 + 460 \text{ ft}^3) = 919.25 \text{ ft}^3$$

- Compute h_{temp1} = temporary storage height for Sand Filter 1 = $V_{\text{temp1}} / (A_{\text{f1}} + A_{\text{s1}})$

$$h_{\text{temp1}} = 919.25 \text{ ft}^3 / (230 \text{ ft}^2 + 368 \text{ ft}^2) = 1.5 \text{ feet}$$

- Check that $h_{\text{temp1}} \geq 2 * h_{\text{f}}$; $2 * h_{\text{f}} = 2 * 1.5' = 3 \text{ ft}$. For Sand Filter 1, the design fits the chamber.
- The distribution slots from the sediment chamber to the filter chamber were assumed to be similar in function to broad-crested weirs that allow flow to exit the sediment chamber and enter the filter chamber once the sediment chamber's water level reaches the minimum wet pool depth of 2 feet. The sedimentation and filter chambers then continue to fill up to D_{max} elevation. The D_{max} elevation was set assuming that the sediment chamber should be sized to hold 50% of WQ_v . These slots would be sized to handle the desired weir flow between the two chambers without allowing the sedimentation chamber's water level to reach the higher bypass weir elevation before the required WQ_v is contained in the two filter chambers. (Note that the minimum wet pool elevation affects the permanent pool elevation in the sedimentation chamber, required maintenance for the sedimentation chamber, mosquito control and possible undesirable odors due to the permanent pool elevation.)

Sand Filter 2:

- Compute V_{f2} = water volume within filter bed/gravel/pipe = $A_{\text{f2}} * d_{\text{f}} * n$

$$V_{\text{f2}} = 160 \text{ ft}^2 * 1.5 \text{ ft} * 0.35 = 84 \text{ ft}^3$$

- Compute V_{w2} = wet pool storage volume = $A_{\text{r2}} * \text{wet pool depth}$

$$V_{\text{w2}} = 160 \text{ ft}^2 * 2 \text{ feet} = 320 \text{ ft}^3$$

- Compute V_{temp2} = temporary storage volume for Sand Filter 2 = $V_{\text{min2}} - (V_{\text{f2}} + V_{\text{w2}})$

$$V_{\text{temp2}} = 1030 \text{ ft}^3 - (84 \text{ ft}^3 + 320 \text{ ft}^3) = 626 \text{ ft}^3$$

- Compute h_{temp2} = temporary storage height for Sand Filter 2 = $V_{\text{temp2}} / (A_{\text{f2}} + A_{\text{s2}})$

$$h_{\text{temp2}} = 626 \text{ ft}^3 / (160 \text{ ft}^2 + 240 \text{ ft}^2) = 1.6 \text{ feet}$$

- Check that $h_{\text{temp2}} \geq 2 * h_{\text{f}} = 2 * 1.5 \text{ feet} = 3 \text{ ft}$.



City of Berea Stormwater Manual Best Management Practices

Example Design

- The distribution slots from the sediment chamber to the filter chamber were assumed to be similar in function to broad-crested weirs that allow flow to exit the sediment chamber and enter the filter chamber once the sediment chamber's water level reaches the minimum wet pool depth of 2 feet. The sedimentation and filter chambers then continue to fill up to D_{max} elevation. The D_{max} elevation was set assuming that the sediment chamber should be sized to hold 50% of WQ_v .

STEP 10 – Design inlets, pre-treatment facilities, underdrain system and outlet structures according to Design Criteria and Design Components.

- **Design inlets** - The inlets to the perimeter filter system are the slotted grates. These grates will be located in the parking area, and must be capable of handling vehicle traffic. For safety, these grates must also be heavy enough so that the grates are not easily removed.
- **Design pre-treatment facilities** – The contributing drainage area to the perimeter sand filter is almost entirely impervious and has low potential for sedimentation. Therefore, no pre-treatment facilities will be installed prior to the perimeter sand filter.
- **Design underdrain system** - Install a 12-inch (1-foot) thick gravel layer with a perforated 8-inch diameter pipe underdrain collection system. The underdrain gravel will be washed and 1½" diameter. The underdrain system will include a 1% slope.
- **Design outlet structures** – The outlet pipes for both sand filter underdrain systems will discharge into the dry detention pond located in the northwest corner of the site.

Sand Filter 1:

The parking lot elevation is at approximately 533 feet near the perimeter sand filter location. With the 3-foot maximum depth for the sedimentation chamber, set the outlet pipe's outlet invert elevation into the dry detention pond at 530 feet. No outlet protection will be required at this outlet pipe, as shear stress and velocities are non-erosive. A second overflow outlet pipe will discharge the overflow runoff collected by the drop inlet when flow conditions exceed the perimeter sand filter's capacity. The overflow outlet pipe will also discharge to the dry detention pond, and will require rock outlet protection as an energy dissipater. The outlet invert for overflow outlet pipe may be at a higher elevation than the sand filter's outlet pipe, but must be below 533 feet.



City of Berea Stormwater Manual Best Management Practices

Example Design

Sand Filter 2:

The parking lot elevation is at approximately 540 feet near the Sand Filter 2 location. With the 3-foot maximum depth for the sedimentation chamber, the outlet pipe's outlet invert elevation into the dry detention pond will be no higher than 537 feet. The discharge from Sand Filter 2 and any overflow runoff will be conveyed overland to the dry detention pond in the northwest corner of the site. The overland area between Sand Filter 2 and the dry detention pond will be well-vegetated to reduce the potential for erosion. For the underdrain outlet pipe, no outlet protection will be required. A second overflow outlet pipe will discharge the overflow runoff collected by the drop inlet when flow conditions exceed the perimeter sand filter's capacity. The overflow outlet pipe will also discharge into the overland areas that drain toward the dry detention pond. Due to the anticipated concentrated flows and velocities at the overflow pipe outlet, rock outlet protection will be installed as an energy dissipater. The approximate slope from the pipe outlets to the dry detention basin is approximately 3%.

STEP 11 – Compute the overflow weir sizes.

- For a perimeter sand filter, the overflow weir is the weir at the end of the sedimentation chamber and allows flows above the weir elevation to enter the filtration chamber.
- The D_{max} for the sedimentation chamber is 3 feet for both sand filters, and defines the maximum chamber heights.
- The overflow weir between the sedimentation chamber and the filtration chamber sets the permanent pool elevation for the sedimentation chamber. The weir elevations for both filters were set at 2 feet above the bottom elevation of the sedimentation chamber to maintain a permanent pool depth that would discourage mosquito breeding here.
- For both perimeter sand filter systems, water levels above the top of the inlet grate would be diverted to the drop inlet for overflow. This flow diversion would not occur until the sand filter had filled to capacity.

STEP 12 – Check volume, peak discharge rates and period of inundation against any applicable state, local and other requirements.

- **Volume** – Both perimeter sand filters were sized to treat the required WQ_v as required by the City.
- **Peak discharge rates** – The peak discharge rate check for the site is more applicable for water quantity control rather than water quality control. The main control for the peak discharge rate is the dry detention pond.
- **Period of inundation** – The underdrain systems for both sand filters were designed using a dewatering time of 36 hours, which is less than the 48-hour maximum.

ADDITIONAL ITERATIONS:

The preliminary designs for both sand filters did not assume that the void space in the underdrain system would count toward the required WQ_v used to size each filter. The preliminary design dimensions could be further refined by subtracting the volume of voids in the underdrain system from the required WQ_v used to size each filter. This refinement may reduce the required filter size as well as other variables such as filter cost. The assumed void space (porosity) for the underdrain filter systems as discussed in the Design Criteria and Design Components is 35% or 0.35.



**City of Berea
Stormwater Manual Best Management
Practices**

**Example
Design**

STEP 13 – Prepare Vegetation and Landscaping Plan

Prior to installing the sand filters, all pervious areas will be stabilized with grass. No additional landscaping requirements apply to the sand filter.

STEP 14 – Prepare operations and maintenance plan

Complete the sand filter operations and maintenance plan based on the guidance given in the Maintenance Section.



STEP 15 – Complete the Design Summary Table

| Design Parameter | Required Size | Actual Size |
|---------------------------|-------------------------|----------------------|
| Sand Filter Type: | Perimeter Sand Filter 1 | |
| WQ _v : | | 2000 ft ³ |
| A _r : | 228.6 ft ² | 230 ft ² |
| Filtration Basin (LxW) | | 46ft x 5ft |
| A _s : | 334 ft ² | 368 |
| Sedimentation Basin (LxW) | | 46ft x 8ft |

| Design Parameter | Required Size | Actual Size |
|---------------------------|-------------------------|----------------------|
| Sand Filter Type: | Perimeter Sand Filter 2 | |
| WQ _v : | | 1373 ft ³ |
| A _r : | 156.9 ft ² | 160 ft ² |
| Filtration Basin (LxW) | | 20 ft x 8 ft |
| A _s : | 229 ft ² | 240 ft ² |
| Sedimentation Basin (LxW) | | 20 ft x 12 ft |

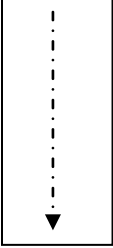

3.4 POST CONSTRUCTION STORMWATER CONTROL FACT SHEETS (PTP)

| Post Construction Stormwater Control Practices | 3.4.2 Open Channel Systems |
|--|---|
| <p>Symbol</p>  <p>TSS Reduction Wet Swale: 75% Dry Swale: 90%</p> |  |
| <p>Description Open channel systems are vegetated swales that are designed to capture, treat, and release stormwater runoff. Open channel systems consist of treatment via dry or wet cells created through the installation of check dams or berms. Wet swales (shown above) and dry swales are two types of open channel systems. Dry swales typically utilize a permeable soil layer, and wet swales typically have wetland plants. Open channel systems treat stormwater while also acting as a stormwater runoff conveyance system. They incorporate water quality features that typical drainage channels do not offer. Installation costs are less expensive than a curb and gutter system, although maintenance costs are typically higher.</p> <p>Open channel systems must be designed with limited longitudinal slopes to reduce runoff velocities and allow particulates to settle. Berms or check dams placed perpendicular to the flow path also aid in reducing velocities and promoting infiltration.</p> <p>Inlets to open channel systems can be enhanced through the use of the following options:</p> <ul style="list-style-type: none">➤ Riprap or other energy dissipaters➤ Pretreatment through a sediment forebay➤ Flow spreader for situations of direct and concentrated flow | |



City of Berea, KY Stormwater Best Management Practices

Applications Open channel systems are designed to manage stormwater runoff for water quality purposes. Open channel systems are typically suitable in the following applications:

- Residential subdivisions of low to moderate density (dry swales)
- Small impervious area in the contributing drainage area
- Along roads and highways (off right-of-way)
- Adjacent to parking lots
- Small drainage areas (less than 5 acres)
- Landscaped commercial areas (wet swales)
- As a pretreatment practice to other BMPs

Open Channel Variations



Figure PTP-02- 1 Dry Swale
Source, Stormwater Managers Resource Center

➤ **Dry Swales**

Dry swales are open channel systems that convey stormwater runoff through vegetation and a filter bed. Sizing for dry swales should allow the entire water quality volume to be filtered or infiltrated through the swale, such that there is no standing water between rain events. Dry swales are the preferred option in residential areas.

Dry swales are made up of an open conveyance channel with a filter bed of prepared soil that overlays an underdrain system. Flow is conveyed into the main channel of the swale where it is filtered by the soil bed. Runoff is then collected and passes into a perforated pipe and gravel underdrain system to the outlet.



Open Channel Variations

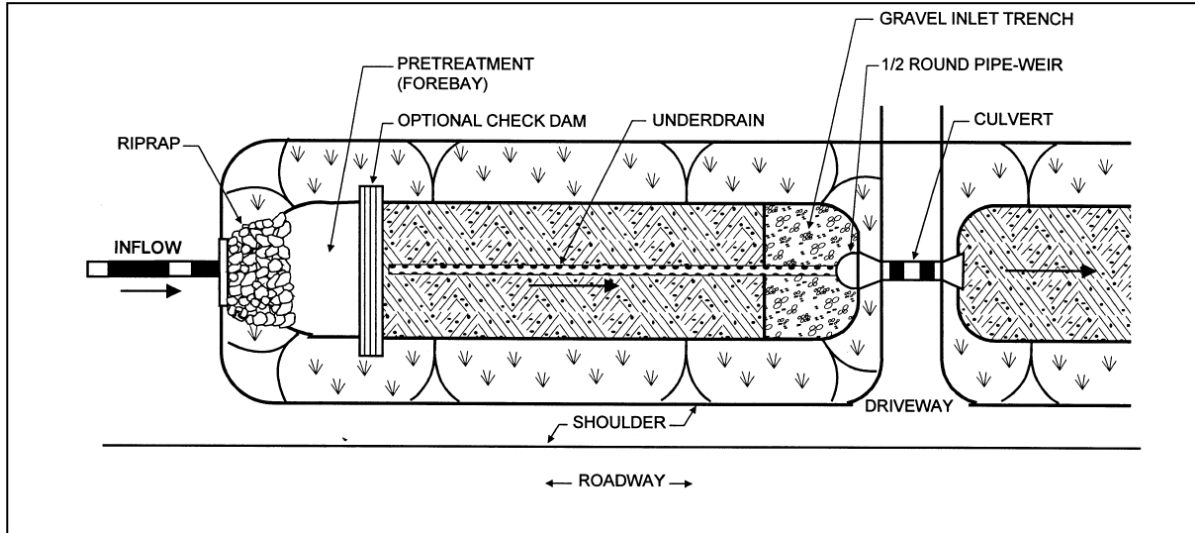

Figure PTP-02- 2 Dry Swale, Plan View
Source, Georgia Stormwater Management Manual

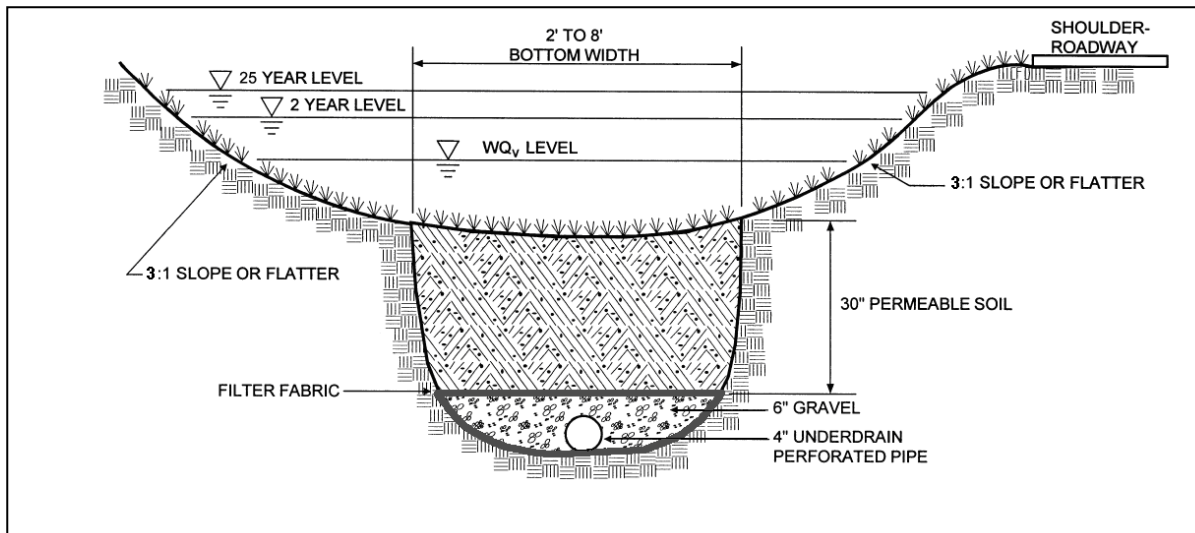

Figure PTP-02- 3 Dry Swale, Cross Sectional View
Source, Georgia Stormwater Management Manual



Open Channel Variations



Figure PTP-02- 4 Wet Swale
Source, Stormwater Managers Resource Center

➤ **Wet Swales**

Wet swales are also referred to as wetland channels. Like the dry swale, wet swales are vegetated channels that treat stormwater runoff. They differ in that wet swales are designed to retain water, imitating marshy conditions and supporting wetland vegetation. A high water table or soils that retain water are necessary to retain water in the system. In these regards, a wet swale is much like a wetland, with a shallow and linear design.

Wet swales are constructed by excavating the channel to the water table or to poorly drained soils. Check dams are installed to create wetland “cells”. These cells contain the runoff similar to a shallow wetland.



City of Berea, KY
Stormwater Best Management Practices

**Open
Channel
Variations**

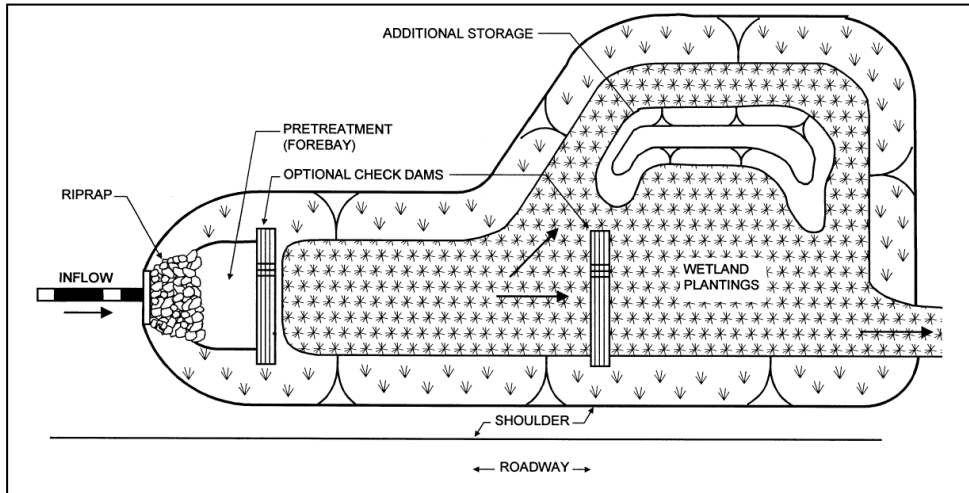

Figure PTP-02- 5 Wet Swale Plan View
Source, Georgia Stormwater Management Manual

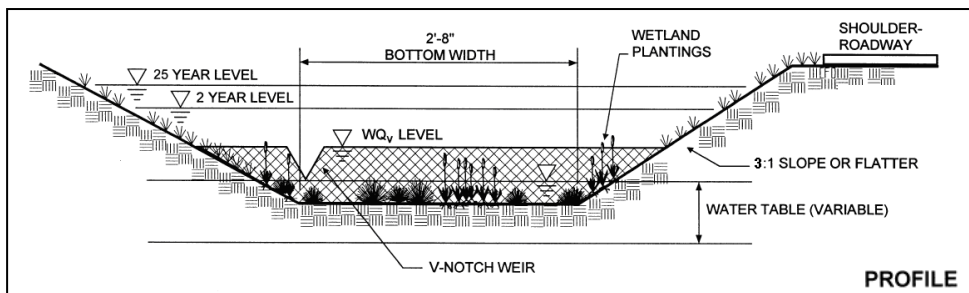

Figure PTP-02- 6 Wet Swale Profile
Source, Georgia Stormwater Management Manual



City of Berea, KY Stormwater Best Management Practices

Design Criteria

Design Criteria

- Limit the contributing drainage to a maximum of 5 acres. One-half (0.5) to two (2) acre drainage areas are preferred.
- Size assuming no losses to infiltration.
- Size channels to store the entire water quality volume with less than 18 inches of ponding.
- Design dry swales to dewater in 24 to 48 hours (24-hours preferred).
- Channel excavation should not result in soil compaction.
- Outlet structures for open channel systems should discharge into the storm drainage system or a stable outfall. For wet swales, incorporate outlet protection to prevent scour and downstream erosion.
- Integrate open channels into the site planning process, and design them to fit aesthetically into the design as attractive green spaces.
- Dry swales require 30 inches of permeable bed material.
- The bottom of dry swales should be at least three feet above the seasonably high water table. For wet swales the seasonably high water table may inundate the swale.
- Dry swales require an underdrain system.
- For wet swales, incorporate check dams and wetland plantings into the channel to form wetland cells. Flow direction can be achieved through the use of V-notch weirs in the check dams.
- The longitudinal slope must be between 1-4% with a channel bottom width of 2'-8'.
- Side slopes must be 3:1 or flatter.
- The channel must be designed to safely and non-erosively convey the 10-year storm event with a minimum of 6 inches of freeboard.

Design Components

- Pretreatment
 - Level Spreader – at locations where lateral flow enters to allow coarse sediment to settle and to evenly distribute flow across the full width of the open channel.
 - Forebay – at locations where concentrated flow enters to allow coarse sediment to settle. The forebay should be sized to contain 10% of the WQv.
 - Filter Strip – reduces velocity of runoff and filters particles in the stormwater. The length of the filter strip depends on the drainage area, imperviousness, and the buffer strip slope.
 - Street/Parking Lot Sweeping – may be used as pretreatment where spatial limitations make structural pretreatment measures infeasible.
- Treatment
 - Channel - the bottom width, depth, length, and slope should be sized to store WQv with less than 18 inches of ponding at the downstream end.
 - Longitudinal slopes must be between 1% and 4% (1-2% preferred). Slopes steeper than 2% may require 6- to 12-inch drop structures to limit the energy to within the recommended 1 to 2% slope range. Spacing between drops should not be closer than 50 feet. Energy dissipation is required below the drops.
 - Bottom width should range from 2 to 8 feet.
 - Side slopes should be no greater than 3:1 (4:1 recommended)
 - Must convey the 10-yr storm with 6 inches of freeboard



City of Berea, KY Stormwater Best Management Practices

Design Components

- Soil Layer (dry swale) –
 - The channel bed shall consist of a 30 inch permeable soil layer.
 - Soil media should have an infiltration rate of at least 0.5 feet per day (fpd) with a maximum of 1.5 fpd.
 - Soil media should have a high organic content to allow pollutant removal
- Underdrain System (dry swale) –
 - Underdrain should consist of an 8 inch diameter perforated PVC pipe, installed longitudinally in a 12 inch gravel layer.
 - Permeable filter fabric must be installed that encompasses the stone underdrain
 - Designed to draw down the WQv in 24-48 hours

Maintenance

Adequate access shall be provided to allow for inspection and maintenance.

- Grass heights should be maintained at heights of approximately 4 to 6 inches for dry swales
- Sediment should be removed from forebay and channel regularly and disposed of properly
- Measure shall be located in a drainage easement.



City of Berea, KY Stormwater Best Management Practices

Design Procedures

Step 1 – Make a preliminary judgment as to whether site conditions are appropriate for the use of an Open Channel System, and identify the function of open channels in the overall treatment system.

- Consider basic issues for initial suitability screening, including:
 - Site drainage area
 - Site topography and slopes
 - Local depth to ground water and bedrock
 - Site location/minimum setbacks
 - Presence of active karst features
- Determine how the open channel system will fit into the overall stormwater treatment system.
 - Decide whether the open channel system is the only BMP to be employed, or if there are other BMPs addressing some of the treatment requirements.
 - Decide where on the site the open channel system is most likely to be located.

Step 2 – Confirm design criteria, site constraints, and applicability.

- Determine the design criteria that will be used.
- Determine any constraints the site will place on the open channel system.
- Ensure that stormwater runoff from impervious surfaces is being treated to the 80%TSS reduction standard.
 - The equation for determining the weighted TSS reduction for a site with multiple outlet points is below.

$$\%TSS = \frac{\sum_n^1 (TSS_1 A_1 + TSS_2 A_2 + \dots + TSS_n A_n)}{\sum_n^1 (A_1 + A_2 + \dots + A_n)}$$

Where:

TSS_1 = TSS reduction by BMP providing treatment for A_1

A_1 = area 1, (acres)

TSS_2 = TSS reduction by BMP providing treatment for A_2

A_2 = area 2, (acres)

- Where one BMP discharges into another, the treatment train TSS reduction can be found by the following equation:

$$TSS_{train} = A + B - \frac{(A \times B)}{100}$$

Where:

TSS_{train} = total TSS reduction through successive BMPs

A = TSS reduction through first BMP

B = TSS reduction through second BMP



City of Berea, KY
Stormwater Best Management Practices

Design

Procedures

Step 3 – Calculate WQ_v .

- Calculate the Water Quality Volume (WQ_v). Channel practices are not designed for stormwater quantity design.
 - The required water quality treatment volume is 1.1 inches of runoff from the new impervious surfaces created by the project.
 - Determine Water Quality Volume (WQ_v).

$$WQ_v = [P R_v](A)]/12$$

Where:

P = is the average rainfall, (inches)

$R_v = 0.05 + 0.009(I)$, where I is the percent impervious cover

A = the area of imperviousness, (acres)

Step 4 – Determine pretreatment method.

- Level Spreader,
- Forebay,
- Filter Strip, or
- Street/Parking Lot Sweeping

Storage volume created for pre-treatment counts toward the total WQ_v requirement, and can be subtracted from the WQ_v for subsequent calculations.



Step 5 – Determine open channel dimensions.

Size bottom width, depth, length, and slope necessary to store WQ_v with less than 18 inches of ponding.

- Longitudinal slope cannot exceed 4% (1 to 2% recommended) or be flatter than 1%
- Bottom width should range from 2 to 8 feet
- Ensure that side slopes are no greater than 3:1 (4:1 recommended)

See Design Criteria for more details.

Step 6 – Compute number of check dams (or similar structures) required to detain WQ_v .

See Design Criteria for more details.

Step 7 – Calculate draw-down time.

- Dry swale channels are sized to store and filter the entire WQ_v and allow for full filtering through the permeable soil layer. The underdrain system in dry swales must be designed to draw down the WQ_v within 24-48 hrs.
- When designing the underdrain, infiltration of the in situ soils should not be considered. Zero drawdown through the in situ soils should be assumed. The underdrain system must be sized to drain the entire water quality volume (WQ_v) within 48hrs



City of Berea, KY
Stormwater Best Management Practices

Design Procedures

- The open channel surface area is computed using the following equation, for those systems that are designed with an underdrain:

$$A_f = (WQ_v \times d_f) / [k \times (h_f + d_f) \times t_f]$$

Where:

- A_f = surface area of the dry swale system, (ft²)
- WQ_v = water quality volume, (ft³)
- d_f = filter bed depth, (ft)
- k = coefficient of permeability of filter media, (ft/day) (0.5 ft/day is the recommended k for the permeable soil layer. This value is conservative to account for clogging associated with accumulated sediment.)
- h_f = average height of water above filter bed, (ft)
- t_f = design filter bed drain time, (days)
 (24- 48 hours is the required drawdown time, t_f , for dry swales)

- Wet swale channels are sized to store the WQ_v .

Step 8 – Design inlets, sediment forebay(s), and underdrain system (dry swale).
 See Design criteria for more details.

Step 9 – Prepare Vegetation and Landscaping Plan.

A landscaping plan for a dry or wet swale should be prepared to indicate how the enhanced swale system will be stabilized and established with vegetation. The appropriate grass species and wetland plants should be chosen based on the site location, soil type, and hydric conditions.

Step 10 – Complete the Design Summary Table.

| Design Parameter | Required Size | Actual Size |
|--------------------------|---------------|-------------|
| Open Channel Type | | |
| WQ_v | | |
| Channel Dimensions (WxL) | | |
| Slope | | |
| Check Dams or other | | |



Example Design



Proposed development of an undeveloped site into an office building and associated parking.

| | | | | | | | | | | | | | | | |
|--|---|------|-----|------|----|----|----|-----------------|------------|-----------|---------|------------|---------|-------------|---------|
| <p>Base Data Total Drainage Area = 5 ac Site Area = 3.54 ac Soils Type "C"</p> <p>Pre-Development Impervious Area = 0 ac; or I = 0% Meadow (CN = 71)</p> <p>Post-Development Impervious Area = 1.72 ac; or I = 1.72/3.54 = 49% Open Space, Fair (CN = 79) Paved parking lots, roofs, driveways, etc. (CN =98)</p> | <p>Hydrologic Data</p> <table border="0"> <tr> <td></td> <td>Pre</td> <td>Post</td> </tr> <tr> <td>CN</td> <td>71</td> <td>89</td> </tr> </table> <p>WQ_v Depth = 1.1 in</p> <p>Precipitation</p> <table border="0"> <tr> <td>l_{wq}</td> <td>2.45 in/hr</td> </tr> <tr> <td>2yr, 24hr</td> <td>3.54 in</td> </tr> <tr> <td>25yr, 24hr</td> <td>5.88 in</td> </tr> <tr> <td>100yr, 24hr</td> <td>7.43 in</td> </tr> </table> | | Pre | Post | CN | 71 | 89 | l _{wq} | 2.45 in/hr | 2yr, 24hr | 3.54 in | 25yr, 24hr | 5.88 in | 100yr, 24hr | 7.43 in |
| | Pre | Post | | | | | | | | | | | | | |
| CN | 71 | 89 | | | | | | | | | | | | | |
| l _{wq} | 2.45 in/hr | | | | | | | | | | | | | | |
| 2yr, 24hr | 3.54 in | | | | | | | | | | | | | | |
| 25yr, 24hr | 5.88 in | | | | | | | | | | | | | | |
| 100yr, 24hr | 7.43 in | | | | | | | | | | | | | | |



City of Berea, KY Stormwater Best Management Practices

Example Design

This example focuses on the design of a dry swale to meet the water quality treatment requirements of the site. Stormwater quantity design is not addressed in this example. In general the primary function of dry swales is to provide water quality treatment and not large storm attenuation. As such, flows in excess of the water quality volume are typically routed to bypass the facility. Where quantity control is required, the bypassed flows can be routed to conventional detention basins (or some other facility such as underground storage vaults).

Problem: Design a water quality treatment plan for this site. A dry detention pond will be constructed to meet the required detention standards and will provide 60% TSS reduction for the site (note that this design example does not address the design of the detention structure). The total drainage area to the pond is 5 ac. Try designing a dry swale to convey the stormwater from the parking area to the dry pond.

Step 1 Make a preliminary judgment as to whether site conditions are appropriate for the use of an Open Channel System, and identify the function of open channels in the overall treatment system.

- Consider basic issues for initial suitability screening, including:
 - The site has type “C” soils
 - There are no minimum setbacks
 - A sinkhole is located on the property where the dry detention facility will be constructed. The dry swale will not be located close to the sinkhole.
- Determine how the open channel system will fit into the overall stormwater treatment system.
 - A dry swale will be constructed in combination with a dry detention pond for water quality and quantity control on the site. Design of the dry detention pond can be found in Section 4.8.
 - See the figure further in the example for site layout. The site has 2 drainage basins, DA1 and DA2. DA1 drains to the dry swale and then discharges into the dry pond. DA2 flows only into the dry detention pond for treatment.
 - The WQ_v treated by the dry swale will be collected by an underdrain and routed to the dry pond located in the northwest corner of the site for water quantity control. Flows greater than the water quality volume will bypass the dry swale and be routed to the dry pond for water quantity control and final polishing prior to discharging.

Step 2 – Confirm design criteria, site constraints, and applicability.

- Determine the design criteria that will be used.
 - Maximum 6 in ponding depth
 - Maximum 48hr drain time from peak water level
 - Minimum 8 in underdrain enveloped in a 12 in gravel layer
 - Minimum 3 ft separation from bottom to seasonally saturated soils
 - 2% longitudinal slope
- Determine any constraints the site will place on the open channel system such as:
 - The dry swale will not be placed near an active sinkhole.
 - Due to topography and layout of the parking area only a portion of the WQ_v can be treated by the dry swale. The other portion of the WQ_v will enter the dry pond directly from the parking area.



City of Berea, KY
Stormwater Best Management Practices

Example Design

➤ Ensure that stormwater runoff from impervious surfaces is being treated to the 80% TSS reduction standard.

- DA1 = 1.03 acres and will discharge into the dry swale and dry pond.
- Determine the treatment train TSS reduction for DA1.
 After the water quality volume for 1.03 acres of the impervious area is treated by a dry swale it is then treated in the dry pond before leaving the site. Dry Swales have a 90% TSS reduction. Dry ponds have a 60% TSS reduction.

$$TSS_{train} = A + B - \frac{(A \times B)}{100}$$

$$TSS_{train} = 90 + 60 - \frac{(90 \times 60)}{100}$$

$$TSS_{train} = 96\%$$

- Dry swale and dry pond treatment train has a 96% TSS reduction $\geq 80\%$ TSS reduction ✓
- DA2 = 0.69 acres and will only be treated by the dry pond. Dry ponds have a 60% TSS reduction.
- Determine the weighted TSS reduction for the site.

$$\%TSS = \frac{\sum_n^1 (TSS_1 A_1 + TSS_2 A_2 + \dots + TSS_n A_n)}{\sum_n^1 (A_1 + A_2 + \dots + A_n)}$$

$$\%TSS = \frac{\sum_2^1 (96 \times 1.03 + 60 \times 0.69)}{\sum_n^1 (1.03 + 0.69)}$$

- $\%TSS = 81.5 \geq 80\%$ TSS reduction ✓

Step 3 – Compute runoff control volumes.

➤ Calculate the Water Quality Volume (WQV).

Water Quality Volume Treated By Dry Swale:

$$WQV = [P R_v(A)]/12$$

Where:

$$P = 1.1 \text{ inches}$$

$$R_v = 0.05 + 0.009(I)$$

$$I = 49$$

$$R_v = 0.05 + 0.009(49) = 0.491$$

$$A = 1.03 \text{ acres}$$

$$WQV = (1.1 \text{ in} \times 0.491 \times 1.03 \text{ ac})/12 = 0.046 \text{ acre-ft} = \mathbf{2004 \text{ ft}^3}$$



Example Design

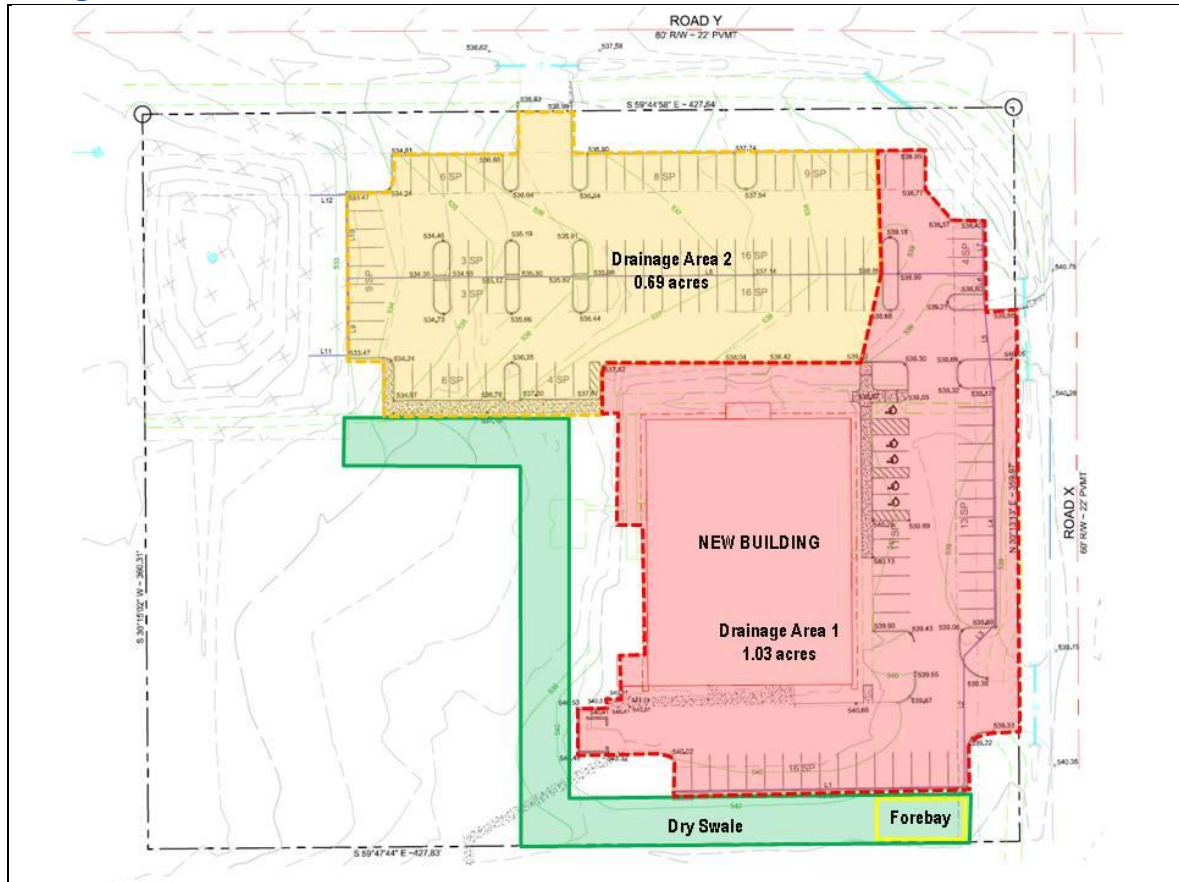

Step 4 – Determine pretreatment method.

- A forebay will be used as pretreatment for the WQ_v.

$$\text{Forebay Volume} = 0.10 (2004 \text{ ft}^3) = 200 \text{ ft}^3$$

- Use a 2 foot deep pea gravel drain at the head of the dry swale to provide erosion protection and to assist in the distribution of the inflow.
- Stormwater will be collected in the parking area and conveyed to the forebay of the dry swale. There will be no significant inflow to the dry swales along its length.

Step 5 – Determine open channel dimensions.

- Assume a trapezoidal channel with a maximum WQ_v depth of 18 inches (9 inch average depth).
- The dry swale has a length of 475 ft, and a slope of 1.1%.
- Assume 4 foot bottom width and 3:1 side slopes.

$$\text{Cross-sectional area} = 0.5 \times 0.75 \text{ ft} \times (4 \text{ ft} + 7 \text{ ft}) = 4.125 \text{ ft}^2$$

$$\text{Volume of Dry Swale} = 4.125 \text{ ft}^2 \times 475 \text{ ft} = 1959 \text{ ft}^3 > 2004 \text{ ft}^3 - 200 \text{ ft}^3 = 1804$$

ft^3 ✓ The WQ_v is reduced by the volume of the pretreatment forebay.



**City of Berea, KY
Stormwater Best Management Practices**

Example Design

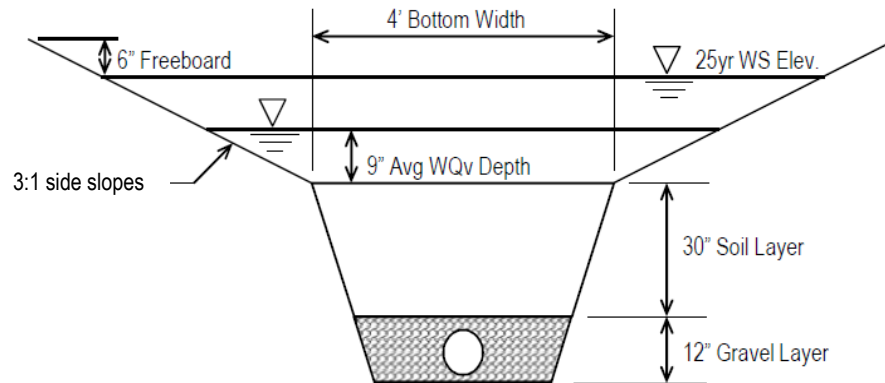

Step 6 – Compute number of check dams (or similar structures) required to detain WQ_v.

- The slope of the dry swale is 1.1% and the maximum depth of is 18 inches.

$$\text{Maximum check dam spacing} = 1.5 \text{ ft} / 1.1\% = 136 \text{ ft}$$

- Place 4 check dams spaced at 118 ft.

Step 7 – Calculate draw-down time.

Check channel geometry to ensure sizing for full drawdown through 8" underdrain.

$$A_f = (WQ_v \times d_f) / [k \times (h_f + d_f) \times t_f]$$

Where:

- A_f = surface area of the dry swale system, (ft²)
- WQ_v = available water quality volume, (ft³)
- d_f = filter bed depth, (ft)
- k = coefficient of permeability of filter media, (ft/day) (0.5 ft/day is the recommended k for the permeable soil layer. This value is conservative to account for clogging associated with accumulated sediment.)
- h_f = average height of water above filter bed, (ft)
- t_f = design filter bed drain time, (days)
(24- 48 hours is the required drawdown time, t_f , for dry swales)

$$A_f = (1959\text{ft}^3 \times 2.5\text{ft}) / [0.5\text{ft/day} \times (0.75\text{ft} + 2.5\text{ft}) \times 2\text{days}]$$

$$A_f = 1506.9 \text{ ft}^2$$

$$\text{Surface area available} = 475' \times 4' = 1900\text{ft}^2 \checkmark$$



**City of Berea, KY
Stormwater Best Management Practices**

Example Design

Step 8 – Design inlets, sediment forebay(s), and underdrain system (dry swale).

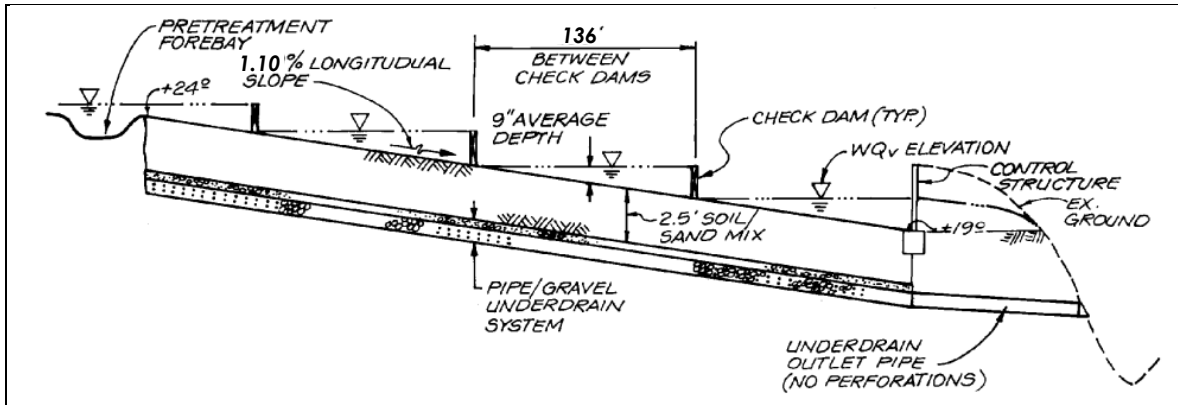

Step 9 – Prepare Vegetation and Landscaping Plan.

- Prepare vegetation and landscaping management plan based on the guidance given in the Landscaping Section.



Step 10 – Complete the Design Summary Table.

| Design Parameter | Required Size | Actual Size |
|--------------------------|------------------------|--|
| Open Channel Type | Dry Swale | |
| WQ _v | 2004 ft ³ | Forebay- 200 ft ³ ; Swale - 1959 ft ³ = 2159 ft ³ |
| Channel Dimensions (WxL) | 1506.9 ft ³ | 1900 ft ³ (475' x 4') |
| Slope | 1.1% | 1.1% |
| Check Dams or other | 4 @ 118ft | 4 @ 118ft |



**City of Berea, KY
Stormwater Best Management Practices**

3.4 POST CONSTRUCTION STORMWATER CONTROL FACT SHEETS (PTP)

| Post Construction Stormwater Control Practices | 3.4.3 Wet Ponds |
|---|--|
|  <p>Symbol</p>  |  |
| <p>Description</p> | <p>Wet ponds are detention ponds containing a permanent pool (or micropool) that allows the treatment of stormwater runoff, while also contributing to the aesthetic value. Wet ponds enhance water quality through settling and biological uptake, and offer a control for sediment, heavy metals, and floatables. They also may provide benefits in reducing impacts due to nutrients, oxygen demanding substances, oil and grease, and bacteria and viruses.</p> <p>The different types of wet ponds consist of the following components: a sediment forebay, a permanent pool, runoff control volume storage, and a shallow littoral zone, or aquatic bench, along the edge of the permanent pool. Other design considerations include an emergency spillway, maintenance access and landscaping.</p> <p>The five types of wet ponds addressed in this fact sheet include the following:</p> <ul style="list-style-type: none">➤ Wet ponds;➤ Wet extended detention ponds;➤ Micropool extended detention ponds;➤ Pocket ponds; and➤ Multiple pond systems. |



City of Berea, KY Stormwater Best Management Practices

Applications

Wet ponds are well-suited for several stormwater water quality benefits, including the following items:

- Areas where high particulate control is needed
- Suitable for large, regional tributaries with sufficient drainage area and/or hydrology to support a permanent pool.
 - Minimum contributing drainage area is 25 acres for wet ponds, wet ED ponds and multiple ponds
 - Minimum contributing drainage area is 10 acres for a micropool extended detention pond (must check that hydrology is capable of supporting water levels)
 - Minimum contributing drainage area is 5 acres for pocket ponds (must check that hydrology is capable of supporting water levels).
- Provides multiple benefits for passive recreation such as bird watching, and wildlife habitat
- Capable of controlling both stormwater quantity and quality issues

Wet ponds also have features that limit where this practice may be used.

- Typically, wet ponds are not feasible for dense or urban land uses due to large land requirements and areas with steep or unstable slopes.
- These ponds have the potential for nuisance insects or odor.
- There are possible safety concerns related to the structure and to maintaining a permanent pool of water.
- Wet ponds may cause increased water temperature, including the potential for downstream thermal impact.



City of Berea, KY Stormwater Best Management Practices

Wet Pond Variations

This practice includes five variations of wet ponds. Each of these types is discussed briefly, and design information specific to a type is also included in the fact sheet.

➤ Wet Ponds



Figure PTP-03- 1 Wet Pond.

Source, *Stormwater Managers Resource Center*

Wet ponds maintain a permanent pool to treat incoming stormwater, and require a contributing drainage area of 25 acres or greater. Treatment occurs through settlement of suspended particles and uptake of dissolved contaminants by aquatic plants between storm events. Wet ponds are constructed with two storage areas: a permanent pool, or “dead,” storage area based on the water quality volume calculation; and a temporary, or “live,” storage area provided above the permanent pool to accommodate larger flows and control erosion. During storm events, runoff displaces the water existing in the permanent pool.

Wet ponds provide for the controlled release of Q_{P25} and Q_{P100} through the spillway outlets. The WQ_v is maintained within the pond’s permanent pool (i.e., there is no spillway opening included to control the release of WQ_v). See Figures PTP-03-3 and PTP-03-4 for schematics of a typical wet pond.



City of Berea, KY
Stormwater Best Management Practices

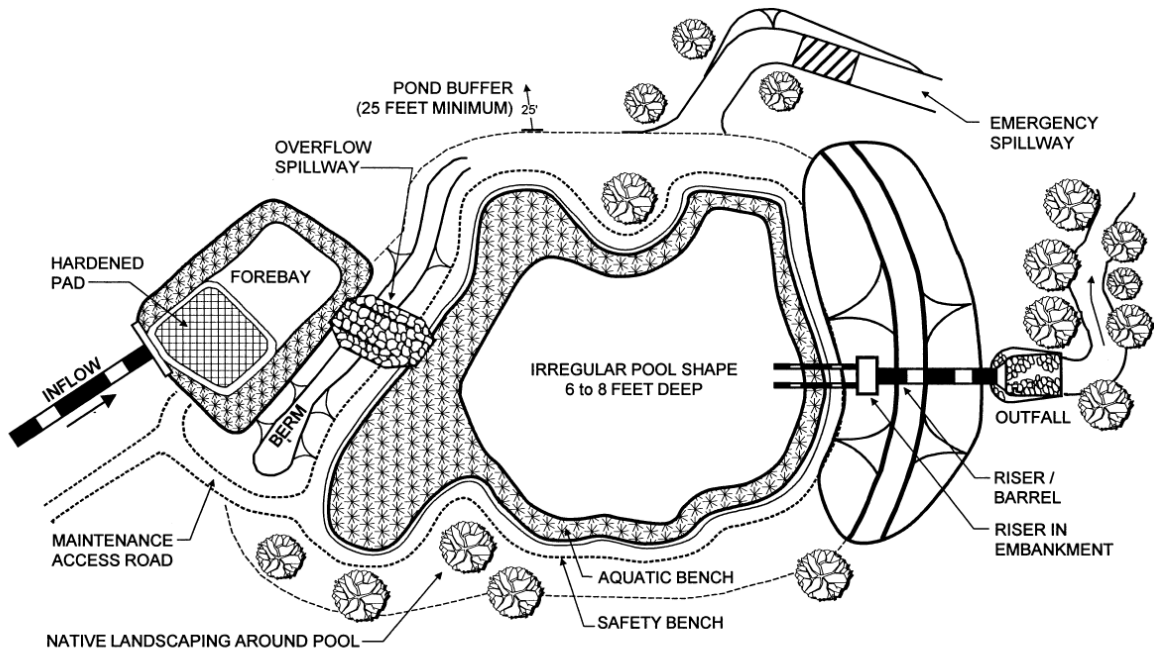

Figure PTP-03- 2 Plan View of Wet Pond
 Source, Georgia Stormwater Management Manual

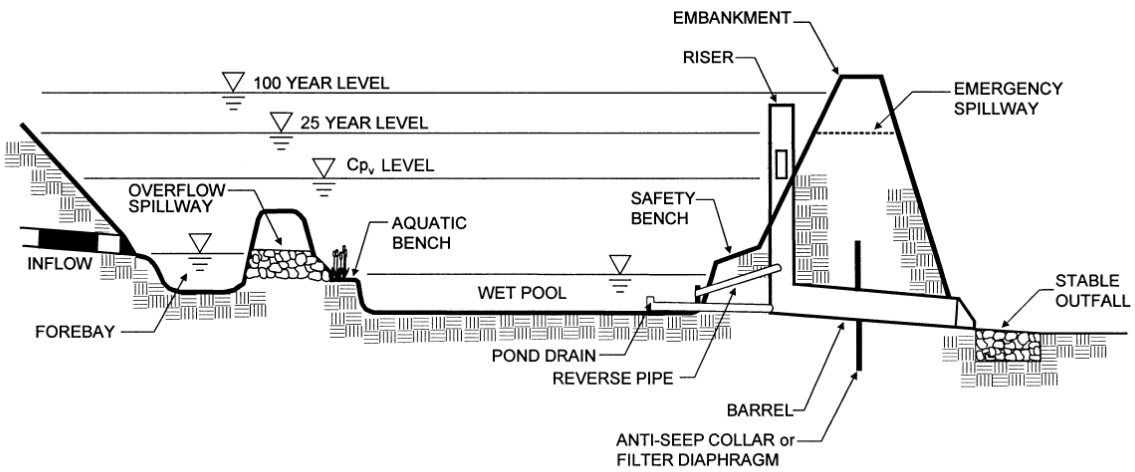

Figure PTP-03- 3 Profile View of Wet Pond.
 Source, Georgia Stormwater Management Manual



City of Berea, KY Stormwater Best Management Practices

Wet Pond Variations

➤ Wet Extended Detention Pond



Figure PTP-03- 4 Wet Extended Detention Pond.

Source, *Stormwater Managers Resource Center*

A wet extended detention (ED) pond is a wet pond where the basin is designed to hold the water quality volume divided evenly between the permanent pool and the extended detention area. This wet pond type requires a minimum of 25 acres of contributing drainage area. During a rain event, water is held in the extended detention area and released over a 24 hour period. Wet ED ponds typically have smaller land area requirements compared to wet ponds. See PTP-03-03 and PTP-03-04 for schematics of a typical wet ED pond.

The wet ED pond is similar to the wet pond in that both pond types provide for the controlled release of Q_{P25} and Q_{P100} through the spillway outlets. However, the wet ED pond also includes a spillway outlet at the top of the permanent pool to allow the controlled release of 50% of WQ_v . The permanent pool will be set to hold 50% of WQ_v , with the remainder of WQ_v released through the spillway outlet at the top of the permanent pool. Figures PTP-03-6 and PTP-03-7 show schematics for wet ED ponds.



**City of Berea, KY
Stormwater Best Management Practices**

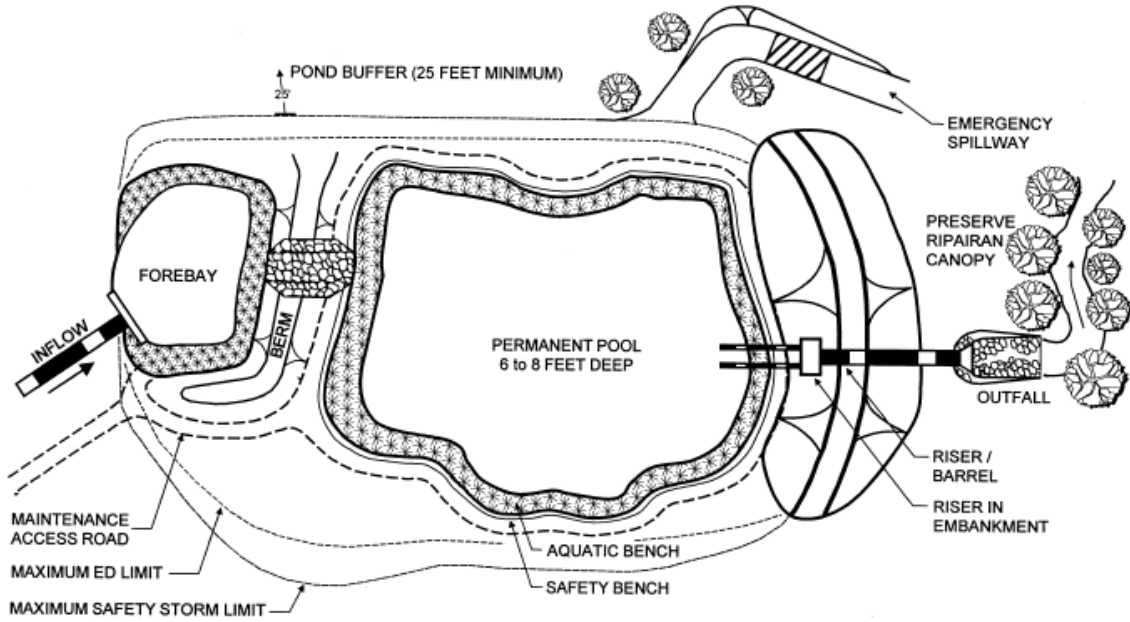

Figure PTP-03- 5 Cross-Section View of Wet Extended Detention Pond.

Source, Minnesota Stormwater Management Manual

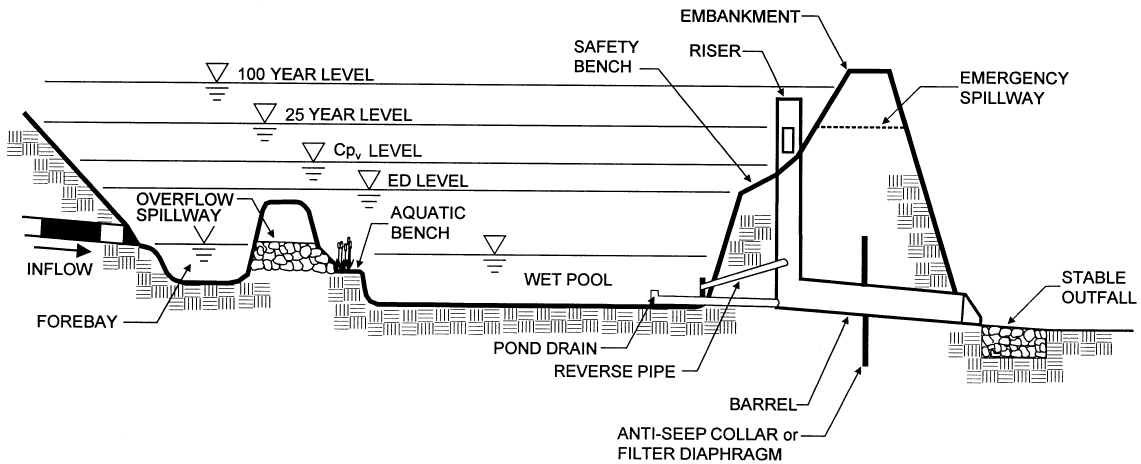

Figure PTP-03- 6 Profile View of Wet Extended Detention Pond.

Source, Georgia Stormwater Management Manual



City of Berea, KY Stormwater Best Management Practices

Micropool Extended Detention Pond



Figure PTP-03- 7 Micropool Extended Detention Pond.
Source, Stormwater Managers Resource Center

A micropool extended detention pond is a basin where a small micropool is permanently maintained at the outlet. The smaller micropool near the pond outlet helps prevent resuspension. The outlet structure is designed to detain the water quality volume for 24 hours and prevents resuspension of sediment particles and clogging of the low flow orifice.

Larger stormwater ponds provide more pollutant removal efficiency than micropool extended detention ponds. However, micropools are ideal for areas where large open stormwater ponds cannot be used or may be undesirable, such as where there are potential thermal impacts to receiving streams, safety concerns in residential areas, or where the contributing drainage area is smaller than what is needed to support a larger wet pond type. See PTP-03-9 and PTP-03-10 for schematics of a micropool ED pond.



City of Berea, KY
Stormwater Best Management Practices

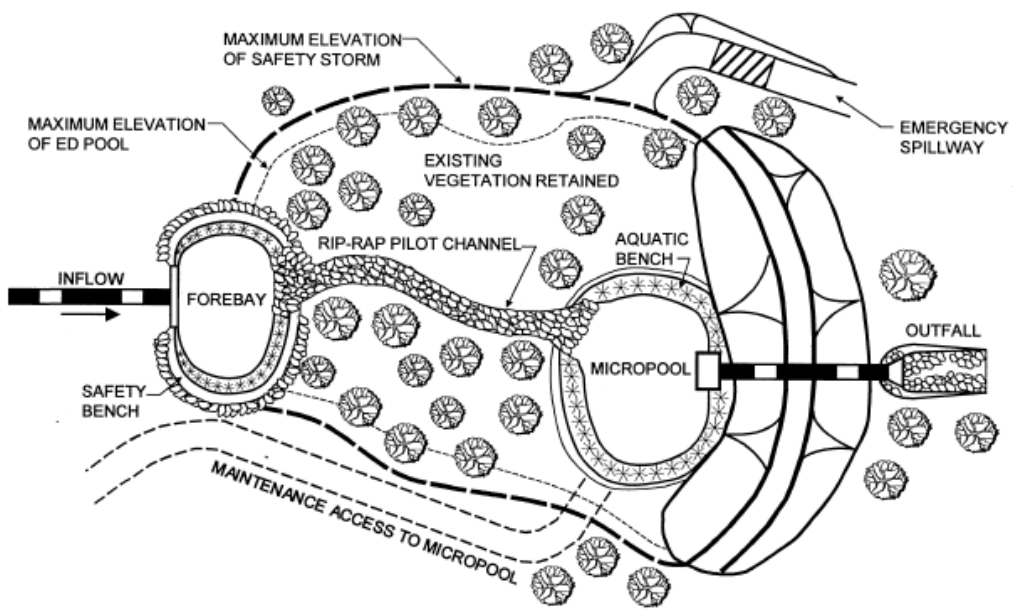

Figure PTP-03- 8 Plan View of Micropool Extended Detention Pond.
Source: Georgia Stormwater Management Manual

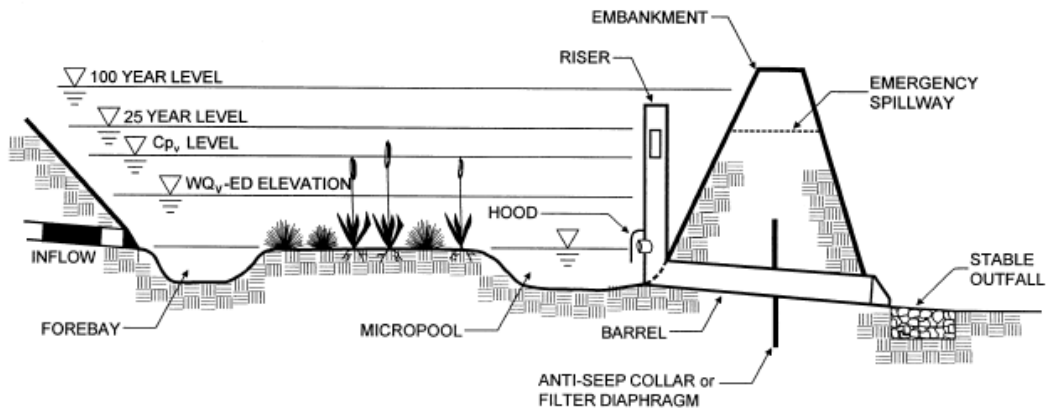

Figure PTP-03- 9 Profile View of Micropool Extended Detention Pond.
Source: Georgia Stormwater Management Manual



City of Berea, KY Stormwater Best Management Practices

Pocket Ponds



Figure PTP-03- 10 Pocket Pond.

Source, Stormwater Managers Resource Center

Pocket ponds are small wet ponds that have smaller contributing drainage areas than other wet pond types. The minimum recommended contributing drainage is 10 acres. These ponds often have little or no baseflow for sustaining water elevations during dry weather, and the permanent pool water elevations rely on a locally high water table or intercepting groundwater. Due to the smaller contributing drainage areas, the pocket pond design should include water balance calculations to assess whether the site's hydrology can sustain a wet pond, including consideration of drought conditions. For land uses where the area draining to the pond may contaminate drinking water supplies, interception of groundwater as a part of stormwater treatment should be avoided (including installation of pocket ponds).

Even though pocket ponds may be well-suited for use for smaller sites where larger wet pond types cannot be used, pocket ponds do have limitations that must be considered in the design. Pocket ponds can be more prone to clogging due to the small size and fluctuating water levels. These fluctuating water levels may also cause other nuisance conditions such as odor and insect habitat when the permanent pool level is diminished.

Pocket ponds should include similar components to those used for other wet pond types even though the pond size will be smaller. The permanent pool for pocket ponds is similar to the micropool for the micropool ED ponds. This permanent pool (micropool) is maintained at the outlet. The outlet structure is designed to detain the water quality volume for 24 hours and prevents resuspension of sediment particles and clogging of the low flow orifice. See Figures PTP-03-12 and PTP-03-13 for pocket pond schematics.



City of Berea, KY
Stormwater Best Management Practices

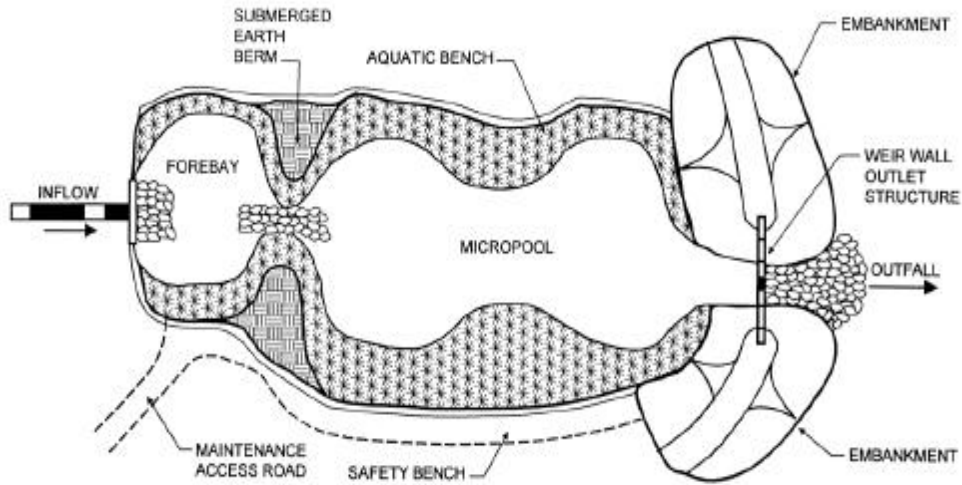

Figure PTP-03- 11 Plan View of Pocket Pond.
Source: Maryland Stormwater Design Manual

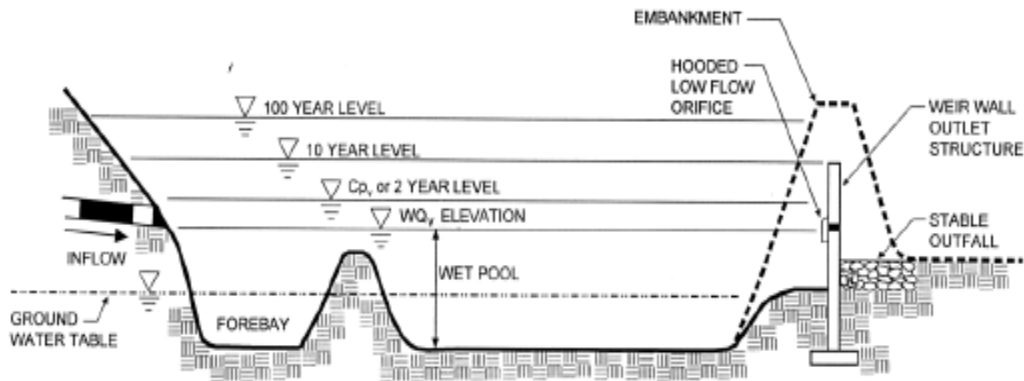

Figure PTP-03- 12 Profile View of Pocket Pond.
Source: Maryland Stormwater Design Manual



City of Berea, KY Stormwater Best Management Practices

Multiple Ponds



Figure PTP-03- 13 Multiple Ponds.

Source, Stormwater Managers Resource Center

A multiple pond system combines one or more wet pond types so that flow passes through the wet ponds in succession. This system increases sediment and pollutant removal from the incoming stormwater. The use of a forebay prior to the first pond can be critical to allowing heavier materials to settle out in the forebay and reducing required maintenance in the wet ponds. Two drawbacks for this multiple pond system would be the required space for multiple ponds and the need to inspect and maintain more than one structure. Using more than one pond must also consider how the permanent pools will be sustained in all wet ponds given the contributing drainage area and water balance. Figures PTP-03-15 and PTP-03-16 show schematics for a two-cell multiple pond system.



City of Berea, KY
Stormwater Best Management Practices

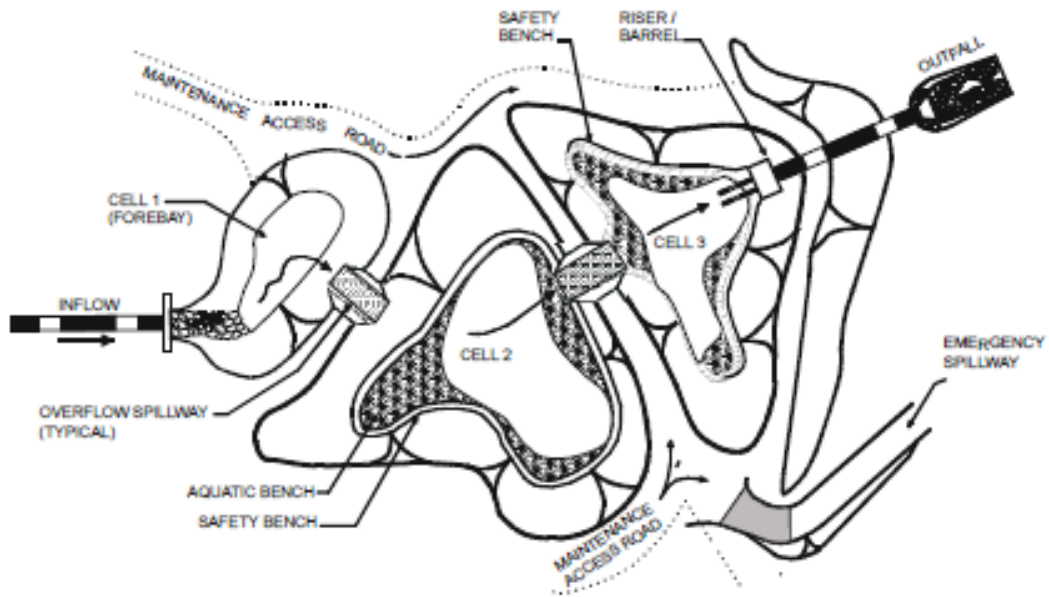

Figure PTP-03- 14 Plan View of Multiple Pond System.
Source: Maryland Stormwater Design Manual

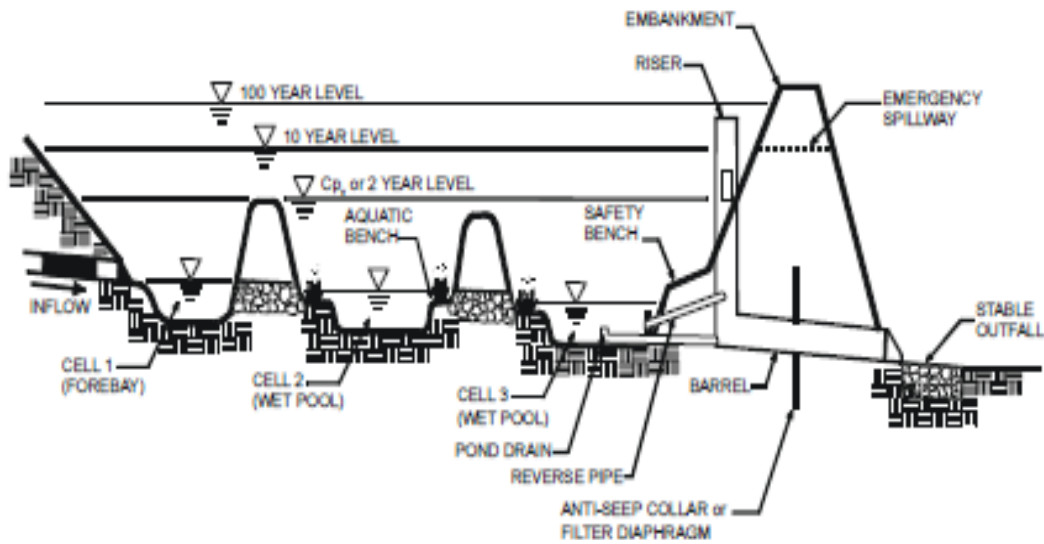

Figure PTP-03- 15 Profile View of Multiple Pond System
Source: Maryland Stormwater Design Manual



City of Berea, KY Stormwater Best Management Practices

Maintenance

Maintenance Plan

A site-specific maintenance plan describing maintenance responsibilities should be developed. that addresses the following items:

- Maintenance access for appropriate equipment, vehicles, and personnel
- Vegetation maintenance schedule that includes mowing multiple times per year
- Inspection checklist
- Maintenance agreement between the facility owner and the City with these items:
 - Sediment removal from sedimentation chamber when sediment depth is $\frac{1}{2}$ of the total depth to the outlet, or is greater than 1.5 feet (whichever is less)
 - Clean and/or repair sediment chamber outlet devices if drawdown times exceed 48 hours 36 hours
 - Trash and debris should be removed as necessary
- Properly dispose of any material generated during maintenance activities.

Monthly to Quarterly or After Major Storms (>1")

Check that the maintenance access is free and clear.

- Inspect low flow orifices and all pipes for clogging.
- Check the pond area for debris, bare soil areas and undesirable vegetation.
 - The minimum mowing requirements for mown slopes will be a spring mowing and a fall mowing.
 - Remove debris.
 - Repair undercut, eroded and bare soil areas.
- Look for damaged safety measures or other dangerous items.

Semi-Annual to Annual

- Ensure that the pond's mechanical components (if any) are functional. Repair broken mechanical components if needed.
- Remove invasive vegetation.
- Monitor and record sediment accumulation.
- Pond vegetation needs to be trimmed or harvested as appropriate.

1-3 Years

- Inspect riser, barrel and embankment for damage. Make any needed repairs.
- Inspect all pipes.
- Monitor sediment deposition in the pond and in the forebay. Remove sediment from the forebay and the pond when needed.



City of Berea, KY Stormwater Best Management Practices

Maintenance **5-25 Years**

- Use remote television inspection of the reverse slope pipes, underdrains or other hard-to-access piping. If needed, replace or repair pipes.

Embankment

The pond embankment and/or riser will require inspection by a qualified professional (e.g., structural engineer, geotechnical engineer, etc.) who has experience in the construction, inspection and repair of these features.



City of Berea, KY Stormwater Best Management Practices

Inspection Checklist

All appropriate items should be checked on the inspection checklist. If an applicable item does not meet the condition on the checklist

Monthly

- Maintenance access is free and clear
- Low flow orifice(s) and pipes are free from clogging.
- Pond areas are free of debris.
- Pond areas do not have any bare soil areas.
- Pond areas do not include any undesirable vegetation (i.e., woody vegetation near the embankment, etc.).
- Check water depth in pond to see if water level has dropped below the permanent pool (look for a fully visible low flow outlet).
 - If the pond water depth is below the permanent pool level, inspector should work to determine why water level has dropped below the permanent pool level (drought conditions or problems with pond).
 - Where low permanent pool levels may produce nuisance insect or odor conditions, the owner should work toward counteracting these conditions until the permanent pool level is restored.
- There are no damaged safety measures or other dangerous items at the pond.

Semi-Annual to Annual

- The pond's mechanical components (if any) are functional.
- The pond's vegetation has been harvested as appropriate.

1-3 Years

- The riser, barrel and embankment were inspected for damage and do not require repairs.
- All pipes were inspected and do not require repairs or replacement.
- The sediment deposition in the pond and in the forebay was checked, and, if needed, sediment was removed from these areas.

5-25 Years

- Use remote television inspection of the reverse slope pipes, underdrains or other hard-to-access piping. If needed, replace or repair pipes.



City of Berea, KY Stormwater Best Management Practices

Design Criteria **General Design**

- A minimum separation distance between the pond and the groundwater table and/or an impervious liner may be required for ponds where source water protection is required or for contributing drainage areas designated as “hot spot” landuses.
- The maximum depth of the pond should not exceed 10 feet.
- For karst areas, it is recommended that ponds use an impermeable liner and include a minimum three foot separation from the barotic rock layer.
- A landscaping plan must address how the pond and the surrounding areas will be stabilized and how vegetation will be established. This plan should include maintenance actions and schedules for the vegetation.

Pre-treatment

- Facilities that receive stormwater from contributing areas with over 50% impervious surface or that are a potential source of oil and grease contamination (hotspots) must include a baffle, skimmer, and grease trap to prevent these substances from being discharged from the facility.
- Require pre-treatment measures such as other water quality BMPs and/or forebay(s). For areas receiving drainage from potential “hot spot” areas, the pre-treatment measures may require an impermeable liner and/or other separation to keep stormwater separated from groundwater.
- The forebay depth should be 4-6 feet deep.
- A sediment forebay sized to 10% of the pond area 0.1 inches per impervious acre of contributing drainage should be provided for all wet ponds
- Direct vehicle/equipment access should be required for forebays to allow for sediment removal and maintenance.
- The forebay may be separated from the remainder of the pond by one of several means: an earthen berm, a concrete weir, gabion baskets, a lateral sill with rooted wetland vegetation, two ponds in series, differential pool depth, rock-filled gabions or retaining wall, or a horizontal rock filter placed laterally across the pond.
- If appropriate, a baffle box or water quality inlet(s) can be used in lieu of a forebay.
- The bottom of the forebay may be hardened using concrete, asphalt or grouted riprap to make sediment removal easier.

Inlet and Outlet Structures

- All extended detention wet ponds and pocket ponds must have a low flow orifice capable of releasing the 50% of WQ_v in the temporary storage area over at least 24 hours. The remaining 50% of WQ_v is in the pond’s permanent pool.
- The water quality protection orifice must meet the following criteria:
 - The minimum diameter for the water quality protection orifice without internal orifice protection is 3 inches.



City of Berea, KY Stormwater Best Management Practices

- The orifice should be protected from clogging by an acceptable external trash rack.
 - The orifice diameter may be reduced to 1 inch if internal orifice protection is used (e.g., an overperforated vertical stand pipe with 0.5-inch orifices or slots that are protected by wirecloth and a stone filtering jacket).
 - Adjustable gate valves may also be used to achieve this equivalent diameter.
- The minimum diameter for the water quality protection orifice without internal orifice protection is 3 inches. The orifice should be protected from clogging by an acceptable external trash rack. The orifice diameter may be reduced to 1 inch if internal orifice protection is used (e.g., an over perforated vertical stand pipe with 0.5-inch orifices or slots that are protected by wire cloth and a stone filtering jacket). Note that a 3 inch diameter orifice or larger is preferred. Adjustable gate valves may also be used to achieve this equivalent diameter.
 - All wet pond types must also include an outlet structure that is sized for QP25 control (based upon hydrologic routing calculations) and can consist of a weir, orifice, outlet pipe, combination outlet, or other acceptable control structure. Small outlets that will be subject to clogging or are difficult to maintain are not acceptable.
 - An emergency spillway is to be included in the stormwater pond design to safely pass the extreme flood flow (QP100). The spillway prevents pond water levels from overtopping the embankment and causing structural damage. The emergency spillway must be designed to State of Kentucky guidelines for dam safety and must be located so that downstream structures will not be impacted by spillway discharges.
 - Inflow channels are to be stabilized with flared riprap aprons, or the equivalent.
 - Pond outlets must be designed to prevent discharge of floating debris.
 - Burying all pipes below the frost line can prevent frost heave and pipe freezing.
 - The outflow riser should be located so that short-circuiting between inflow points and riser does not occur.
 - Riprap, plunge pools or pads, or other energy dissipators are to be placed at the end of the outlet to prevent scouring and erosion. Large facility outlets may also require an anti-vortex device.

Permanent Pool

- The permanent pool's contours and shape should be irregular to compliment natural landscaping.
- The permanent pool may be excavated into bedrock for a wet pond
- The maximum permanent pool depth is generally less than 8 feet. Deeper depths may allow thermal stratification and anaerobic conditions to occur, causing odor problems if no artificial mixing or aerators are used.



City of Berea, KY Stormwater Best Management Practices

Design Criteria

- Greater depths near the outlet may allow water to cool and minimize thermal impacts to receiving streams.
- Minimum depth of the permanent pool should be 3 to 4 feet.

Embankment

- Vegetated embankments shall be less than 20 feet in height and shall have side slopes no steeper than 2:1 (horizontal to vertical) although 3:1 is preferred. Riprap-protected embankments shall be no steeper than 2:1. Geotechnical slope stability analysis is recommended for embankments greater than 10 feet in height and is mandatory for embankment slopes steeper than those given above. All embankments must be designed to State of Kentucky guidelines for dam safety.
- Seepage control or anti-seep collars should be provided for all outlet pipes.
- A minimum of 1 foot of freeboard must be provided for earthen embankments.
- Earthen embankment slopes should be vegetated to avoid erosion. Drought tolerant groundcover species should be used if irrigation cannot occur during the summer.

Maintenance and Safety

- Adequate maintenance access such as a maintenance access bench must be provided for all wet ponds. The access bench is a shallow slope area adjacent to the pond that will be used for equipment access.
- The forebay of the pond should include a fixed vertical sediment depth marker securely installed in the forebay. This marker will be used as an indicator for when sediment removal is needed in the forebay. Sediment removal should occur for forebay areas every 2-7 years or after 50% of the total forebay storage capacity is filled with sediment.
- The riser should be planned for future maintenance, lessening the clogging potential, planning access for inspections and maintenance, and safety from improper access by children and/or vandals.
- Public safety must be considered in every aspect of the pond design.
- Dam safety regulations must be strictly followed in pond design and maintenance to ensure that downstream property and structures are adequately protected.
- OSHA safety procedures must be followed for maintenance activities in enclosed areas, such as outlet structures.
- All wet ponds must include a drain and written procedures for draining the pond.

Multiple Pond Systems

- Performance is enhanced by using multiple treatment cells, longer flowpaths and high surface area to volume ratios.
- For separating multiple ponds, a berm or simple weir is preferred rather than using pipes because pipes have higher freezing potential.



City of Berea, KY Stormwater Best Management Practices

Design Components

Pre-Treatment

- Wet ponds require pre-treatment measures such as other water quality BMPs and/or forebay(s). For pre-treatment areas receiving drainage from potential “hot spot” areas, the pre-treatment measures may require an impermeable liner and/or other separation to keep stormwater separated from groundwater.
- A sediment forebay sized to 0.1 inches per impervious acre of contributing drainage should be provided for wet ponds that are in a treatment train with off-line water quality treatment structural controls. This forebay may be a small pool separated from the pond area by barriers such as earthen berms, concrete weirs or gabion baskets.
- Direct vehicle/equipment access should be required for forebays to allow for sediment removal and maintenance.
- The bottom of the forebay may be hardened using concrete, asphalt or grouted riprap to make sediment removal easier.
- The forebay outlets should include non-erosive conditions as flows move from the forebay to the pond.
- Channels used to convey runoff to the pond should be stabilized to reduce the sediment loads.
- The forebay of the pond should include a fixed vertical sediment depth marker securely installed in the forebay. This marker will be used as an indicator for when sediment removal is needed in the forebay. Sediment removal should occur for forebay areas every 2-7 years or after 50% of the total forebay storage capacity is filled with sediment.
- Removed sediment from pond areas that do not receive runoff from confirmed hotspots is generally not considered toxic or hazardous material, and can be safely disposed by land application or land filling. For sediment from runoff from hotspot areas, sediment testing may be necessary prior to disposal.

Inlet and Outlet Structures

- For extended detention ponds and pocket ponds, the low flow orifice must be capable of releasing 50% of WQ_v over at least 24 hours.
- For a wet pond, the outlet structure is sized for QP25 control (based upon hydrologic routing calculations) and can consist of a weir, orifice, outlet pipe, combination outlet, or other acceptable control structure that is not easily clogged.
- The water quality protection orifice should have a minimum diameter of 3 inches and should be adequately protected from clogging by an acceptable external trash rack. The orifice diameter may be reduced to 1 inch if internal orifice protection is used (e.g., an overperforated vertical stand pipe with 0.5-inch orifices or slots that are protected by wirecloth and a stone filtering jacket). Adjustable gate valves can also be used to achieve this equivalent diameter.



City of Berea, KY Stormwater Best Management Practices

Design Components

- The two most common outlet problems that occur are: 1) the outlet capacity is too great, resulting in partial filling of the pond, shorter drawdown time, and reduced pollutant removal; and 2) the outlet clogs because it is not adequately protected against trash and debris.
To avoid these problems, two alternative outlet types are recommended for use: 1) V-notch weir; and 2) perforated riser. The V-notch weir will not clog as easily and should be designed to extend at least 12 inches below the normal pool. The perforated riser allows flow to enter at varying depths, providing internal flow control at varying depths and treatment volumes. The number of perforations per row is a function of the outlet sizing for the pond.
- An emergency spillway may be required in wet pond designs to safely pass the extreme flood flow. The spillway prevents pond water levels from overtopping the embankment and causing structural damage. The emergency spillway must be designed to State of Kentucky guidelines for dam safety and must be located so that downstream structures will not be impacted by spillway discharges.
- Inflow channels are to be stabilized with flared riprap aprons, or the equivalent.
- The principal spillway opening should not permit entry by small children, and endwalls above pipe outfalls greater than 48 inches in diameter should be fenced to prevent a hazard.
- Pond outlets must be designed to prevent discharge of floating debris. The recommended approach is to equip the principal spillway openings with removable trash racks to prevent clogging by large debris and to restrict riser access for safety. U.
S. EPA guidance for controlling floatables suggests that openings in the range of 1.5 inches are both cost-efficient and effective in removing floatables and large solids.
- The riser should be planned for future maintenance, lessening the clogging potential, planning access for inspections and maintenance, and safety from improper access by children and/or vandals.
- OSHA safety procedures must be followed for maintenance activities in enclosed areas, such as outlet structures.
- The recommended approach for limiting riser access is to install lockable manhole covers and manhole steps within easy reach of valves and other controls. These measures will allow maintenance access and help prevent unauthorized access.
- For spillway outlets, flared pipe sections that discharge at or near the downslope invert or a step-pool arrangement are recommended rather than headwalls at the spillway outlet.
- Burying all pipes below the frost line can prevent frost heave and pipe freezing.
- A riser or an alternative method may be used for the pond's principal spillway.
 - For perforated risers, the minimum opening diameter should be ½ inch and the minimum pipe diameter is 8 inches.



City of Berea, KY Stormwater Best Management Practices

Design Components

- The low flow orifice for the riser must be adequately protected from clogging. This protection may be an acceptable external trash rack (recommended minimum orifice diameter of 3 inches) or a smaller orifice diameter may be used along with internal orifice protection (recommended minimum diameter of 1 inch).
- One example alternative method would be to use a broad crested, rectangular, V-notch or proportional weir, protected by a half-round CMP.
- The outflow riser should be located so that short-circuiting between inflow points and the riser does not occur.
- Where standard weirs are used, the minimum slot width is 3 inches. This is particularly important for tall slots.
- The pond must include an emergency spillway to pass storm events in excess of the pond's hydraulic design. The emergency spillway must be stabilized to prevent erosion, must comply with state dam safety requirements and must be located so that downstream structures will not be impacted by spillway discharges. If the emergency spillway crosses the maintenance access for the pond, materials meeting the appropriate load requirements must be selected.
- Riprap, plunge pools or pads, or other energy dissipators are to be placed at the end of the outlet to prevent scouring and erosion. If the pond discharges to a channel with dry weather flow, care should be taken to minimize tree clearing along the downstream channel, and to reestablish a forested riparian zone in the shortest possible distance.
- For outlets, it is recommended that a stilling pond or outlet protection be used to reduce outflow velocities to non-erosive velocities (3.5 to 5.0 fps).

Pond

- Wet ponds require a minimum contributing drainage area and may also require water balance calculations to confirm that a wet pond can be supported at the location.
 - Minimum contributing drainage area is 25 acres for wet ponds, wet ED ponds and multiple ponds
 - Minimum contributing drainage area is 10 acres for a micropool extended detention pond (must check that hydrology is capable of supporting water levels)
 - Minimum contributing drainage area is 5 acres for pocket ponds (must check that hydrology is capable of supporting water levels).
- Side slopes should be 6:1 (H:V) or flatter to provide a littoral shelf and safety bench from the side of the facility out to a point 2 to 3 feet below the permanent pool elevation. Side slopes above the littoral zone should be no steeper than 4:1 (H:V). Side slopes below the littoral zone can be 2:1 (H:V) to maximize permanent pool volumes where needed. A short (1.0 ft) drop-off can be constructed at the edge of the pond to control the potential breeding of mosquitoes.



City of Berea, KY Stormwater Best Management Practices

Design Components

- For outlets, it is recommended that a stilling pond or outlet protection be used to reduce outflow velocities to non-erosive velocities (3.5 to 5.0 fps).
- Dam safety regulations must be strictly followed in pond design and maintenance to ensure that downstream property and structures are adequately protected.
- Public safety must be considered in every aspect of the pond design.
- The minimum length to width ratio for the pond is 1.5:1.
- It is recommended that the pond's footprint cover approximately 1-3% of the contributing drainage area.
- Adequate maintenance access must be provided for all wet pond types. One approach for this is to incorporate an access bench (a shallow slope area adjacent to the pond) that will be used for equipment access.
 - The recommended access bench width is 10 feet (minimum 8 feet).
 - The maximum access bench cross-slope should be 0.06:1 (V:H) or 6%.
 - Use a maximum bench slope of 0.15:1 (V:H).
 - The bench should be appropriately stabilized for vehicle and equipment access.
 - This bench may also consider extending to other areas such as forebays, inlet and outlet, and should also consider the need for vehicle turn around space.
 - Access benches are not needed for ponds with side slopes that are 1:4 (V:H) or flatter.
 - The recommended maintenance access will connect with a maintenance right-of-way or easement (if needed) that will extend from the pond to a public or a private road.
- A minimum separation distance between the pond and the groundwater table and/or an impervious liner may be required for ponds where source water protection is required or for contributing drainage areas designated as "hot spots".
- A site-specific geotechnical investigation should be conducted.
- Side slopes should not exceed 1V:3H.
- The slopes immediately adjacent to the pond should be less than 25% but greater than 0.5-1% to maintain positive drainage toward the pond.
- Wet ponds are sized to store all of WQ_v in the permanent pool and to temporarily store the volume of runoff required to provide overbank flood (QP_{25}) protection (i.e., reduce the post-development peak flow of the 25-year storm event to the pre-development rate), and control the peak flow for the 100-year storm (QP_{100}) if required.
- Wet ED ponds, micropool ED ponds and pocket ponds are designed to store 50% of WQ_v in the permanent pool and the remainder of WQ_v in temporary storage for at least 24 hours. These ponds can also provide additional storage volume for normal detention (peak flow reduction) for QP_{25} and QP_{100} . Routing calculations must be used to demonstrate adequate storage volume.



City of Berea, KY Stormwater Best Management Practices

Design Components

- The maximum depth of the pond should not exceed 10 feet.
- The elevation difference from the site inflow to outflow is recommended to be 6-10 feet. However, lower heads may also work for smaller sites.
- The recommended pond side slopes would be 1:3 (V:H).
- Construction inspections are needed to confirm that the pond is being built by the approved design and specifications. Use a detailed inspection checklist that includes sign-offs by qualified individuals at critical construction stages to check that the contractor's plan interpretation is acceptable to the project's designer.
- Areas above the normal high water elevations of the pond should be sloped toward the pond to allow drainage and to prevent standing water. Carefully finish grading to avoid creation of upland surface depressions that may retain runoff. The pond bottom should be graded toward the outlet to prevent standing water conditions. A low flow or pilot channel across the pond bottom from the inlet to the outlet (often constructed with riprap) helps convey low flows and prevent standing water conditions.
- For karst areas, it is recommended that ponds use an impermeable liner and include a minimum three foot separation from the barotic rock layer. Liner options include a layer of 6-12 inches of clay soil including bentonite (minimum 15% passing the #200 sieve and a maximum permeability of 1×10^{-5} cm/sec), a 30 mL polyliner or another approved engineering design.
- A landscaping plan should describe how the pond and surrounding areas will be stabilized, how vegetation will be established, how these areas will be maintained and maintenance schedules.
 - Rooted wetland vegetation should be planted along the pond's perimeter.
 - Keep in mind that vegetation planted in the extended detention zone should be able to withstand both wet and dry conditions.
- All wet ponds must include a drain and written procedures for draining the pond.

Embankment

- Vegetated embankments shall be less than 20 feet in height and shall have side slopes no steeper than 2:1 (horizontal to vertical) although 3:1 is preferred. Riprap-protected embankments shall be no steeper than 2:1. Geotechnical slope stability analysis is recommended for embankments greater than 10 feet in height and is mandatory for embankment slopes steeper than those given above. All embankments must be designed to State of Kentucky guidelines for dam safety.
- Seepage control or anti-seep collars should be provided for all outlet pipes.
- A minimum of 1 foot of freeboard must be provided, measured from the top of the water surface elevation for the extreme flood, to the lowest point of the dam embankment not counting the emergency spillway.
- For earthen embankments, suitable soils must be used to construct the embankment.
- Woody vegetation should not be planted or allowed to grow within 15 feet of the embankment toe and within 25 feet of the inlet and outlet structures.



City of Berea, KY Stormwater Best Management Practices

Design Components

Multiple Pond Systems

- Performance is enhanced by using multiple treatment cells, longer flowpaths and high surface area to volume ratios.
- For separating multiple ponds, a berm or simple weir is preferred rather than using pipes because pipes have higher freezing potential.

Design Procedure

Step 1 – Make a preliminary judgment as to whether site conditions are appropriate for the use of a type of wet pond, and identify the function of the pond in the overall treatment system. This includes performing an initial suitability screening for the site.

- Consider basic issues for initial suitability screening, including:
 - Site drainage area
 - Site topography and slopes
 - Soil characteristics
 - Depth to water table and bedrock
 - Presence of active karst features and/or wetlands
 - Post-development landuse (Is it a potential “hot spot” landuse?)
- Determine how the type of wet pond will fit into the overall stormwater treatment system.
 - Keep in mind that other water quality BMPs may be used upslope of the pond that may reduce the required pond size.
 - Decide where on the site the pond is most likely to be located.

Step 2 – Confirm design criteria, site constraints and applicability.

- Determine the design criteria that will be used.
 - Local construction and stormwater requirements
 - State stream construction permitting (if in a floodplain area)
 - State dam safety guidance (for ponds with embankments)
 - Any other criteria or restrictions that apply
- Determine any constraints the site will place on the pond such as:
 - Available contributing drainage area
 - Limited amount of space and surface area available for treatment
 - High water table
 - Active karst areas



City of Berea, KY Stormwater Best Management Practices

Design Procedure

- Determine the TSS reduction provided, using the equations below for weighted TSS reduction, $TSS_{weighted}$, and TSS treatment train, TSS_{train} . The minimum TSS reduction required for the site is 80% and can be weighted for the site.

$$\%TSS_{weighted} = \frac{\sum_n^1 (TSS_1 A_1 + TSS_2 A_2 + \dots + TSS_n A_n)}{\sum_n^1 (A_1 + A_2 + \dots + A_n)}$$

Where runoff is treated by two or more BMPs in series, the TSS reduction provided is calculated with the following equation for a treatment train:

$$TSS_{train} = A + B - \frac{(A \times B)}{100}$$

Where A is the TSS reduction provided by the first BMP and B is the TSS reduction provided by the next BMP.

Step 3 – Confirm site suitability, including field verification of site suitability.

- The field verification should be conducted by a qualified geotechnical professional.
- The recommended minimum is one soil boring per acre with a minimum of three soil borings or pits dug at the same location as the proposed pond. The borings or pits will be used to verify soil types and to determine the depth to groundwater and bedrock.
- The recommended minimum depth of the soil borings or pits is five feet below the bottom elevation of the proposed pond.
- Perform water balance calculations, if needed. A water balance is recommended where there is a need to document sufficient inflows to support a wet pond type. The water balance considers the site's ability to maintain a constant permanent pool during prolonged dry weather conditions. Use the following steps to perform water balance calculations:
 - Check maximum drawdown during periods of high evaporation and during an extended period of no appreciable rainfall to ensure that wetland vegetation will survive.
 - The change in storage within a pond = inflows – outflows.
 - Potential inflows: runoff, baseflow and rainfall (ground water and surface water).
 - Potential outflows: Infiltration, surface overflow and evapotranspiration.
 - For some wet pond types, some assumptions can help simplify the water balance since only the permanent pool volume is being evaluated. . The validity of these assumptions need to be verified for each design and wet pond type.
 - Assume no inflow from baseflow,



City of Berea, KY Stormwater Best Management Practices

Design Procedure

- Assume no outflow losses for infiltration
- Assume no outflow losses for surface overflows
- In equation format, the water balance based on the contributing drainage area is as follows:

Where:

ΔSP = change in pond storage, inches

RO = runoff, inches

B = baseflow, inches

RF = rainfall, inches

I = infiltration, inches

SO = surface overflow, inches

ET = evapotranspiration, inches

- For testing a site's suitability for a wet pond type, the critical issue is maintaining a minimum permanent pool depth to avoid nuisance conditions such as insect conditions or odor. The water balance equation may be modified to calculate the required design depth for the permanent pool by considering 30-day summer drought conditions. In equation format, the 30-day water balance based on the contributing drainage area is as follows:

Where:

DP = Average design depth of the permanent pool, inches

ETS = Summer evapotranspiration amount, inches

IS = Summer infiltration amount, inches

RES = Pond's water reservoir for a factor of safety (assume 24 inches)

BS = Summer baseflow amount, inches



City of Berea, KY Stormwater Best Management Practices

Design Procedure

Step 4 – Compute runoff control volumes, permanent pool volume and peak flows. Refer to Section 2.4.7 for more information on these values.

- Calculate the Permanent Pool Volume (V_{PP}).

Where:

V_{PP} = Permanent Pool Volume, acre-feet

A_W = total watershed area draining to the pond, acres

- Calculate the Water Quality Volume (WQ_V).

$$WQ_V = [P R_v(A)]/12$$

Where:

P = is the average rainfall, (inches)

R_v = $0.05 + 0.009(I)$, where I is the percent impervious cover

A = the area of imperviousness, (acres)

- Calculate the Peak Flow for the 25 year storm (QP_{25}).
- Calculate the Peak Flow for the 100 year storm (QP_{100}).
If the pond will be used as the only BMP for rate control for larger storms, the pond should be designed to treat the entirety of each of these runoff control volumes. If other BMPs will be used to control portions of these runoff control volumes, the portion handled by other BMPs may be subtracted from the appropriate volumes to determine the volumes to be controlled in the pond.

Note: Steps 5 – 12 may be iterative to achieve a pond design that meets the required performance and the site constraints.

Step 5 – Determine the pond location and preliminary geometry.

- Use the following steps to develop the preliminary grading plan for the pond.
 - Locate the pond at the site's lowest elevation area that is not in a jurisdictional wetland or active karst area. Provide space around the pond for maintenance access (minimum width of 8 feet, recommended minimum width of 10 feet).
 - Establish a primary outlet elevation (normal water level) and/or a pond bottom elevation.
 - Provide storage for the permanent pool below the primary outlet elevation in the main pond area.



City of Berea, KY Stormwater Best Management Practices

Design Procedure

- The permanent pool should include an aquatic bench extending into the pool and an access bench extending out of the pool.
 - Provide storage based on the water quality volume (WQV), volume for the Peak Flow (VP25) and volume for the Extreme Flood Peak Flow (VP100). The pond must be able to contain the first two volumes, and must be designed to pass the extreme flood peak flow.
 - Considering the desired pond footprint during the WQV, VP25 and VP100 design storms, allocate storage volume above the riser bottom orifice for WQV, VP25 and VP100, respectively. While developing the grading plan, consider the desired (or required) length to width ratio and side slopes based on the Design Criteria and Design Components information.
 - Once the preliminary grading plan has been developed, determining the associated stage-storage relationship for water surface elevations through the maximum expected levels.
- Use the average end area method to calculate the approximate storage at a given stage (elevation). The area within each of the closed contour lines on the pond's grading plan is measured. The average area is calculated between two adjacent contours. The average areas are then multiplied by the elevation difference to calculate the approximate volume between the two contours.

$$\text{Volume} = \frac{A_1 + A_2}{2} (E_2 - E_1)$$

Where:

V₁₋₂ = the volume between contour 1 and contour 2 (acre-feet)

A₁ and A₂ = the areas within closed contours 1 and 2, respectively (acres)

E₁ and E₂ = the elevations of contours 1 and 2, respectively (feet)

The cumulative pond volume above the bottom of the pond can be calculated by adding the incremental volumes. The stages (elevations) and the corresponding storages can be used to develop a stage-storage-discharge table as the outlet structures are designed. This is an iterative process that may require revising the preliminary grading plan and recalculating the stage-storage relationship until all of the items in Design Criteria and Design Components are satisfied.



City of Berea, KY Stormwater Best Management Practices

Design Procedure

STEP 6 – Determine the pre-treatment volume for the sediment forebay.

- Where there are no adequate upstream treatment BMPs, a sediment forebay or a similarly performing treatment system is recommended at each inlet to the pond that conveys 10% or more of the total design inflow.
- The recommended forebay volume is 10% of the WQ_v with a depth of 4-6 feet. More shallow depths increase the potential for sediment resuspension in the forebay.
- Both the storage volume of the forebay and the storage volumes for other water quality BMPs upstream in the treatment train count toward the required water quality volume, and may be subtracted from the total water quality volume required.

STEP 7 – Size and design the outlet structures.

- The pond must include the following outlet stages in the pond design. It is possible to design one device to meet all required stages.
- The assumed water quality volume (low flow) outlet is an orifice at the bottom of the riser designed to release WQ_v with an average detention time of 24 hours. After designing the low flow orifice, the design should be checked to verify that the release rate is no greater than 5.66 cfs/acre of pond surface area.
- The following outlet equations are based on assumptions about the outlet structure type that will be used to control flows at various stages. If a different structure type is selected, the designer must use specific equations for structure type to determine the stage-discharge relationships. However, the general design approach will remain the same even if a different outlet structure type is used for the pond calculations.
- The average release rate of WQ_v (QWQ_{avg}) is calculated using the following equation:

Where:

t_{WQ} = the intended WQ_v detention time
(seconds) WQ_v = water quality volume (cubic
feet)

QWQ_{avg} = average release rate of WQ_v (cfs)

- From the stage-storage table, find the elevation associated with WQ_v . Calculate the approximate average head (in feet) on the water quality outlet (hwq_{avg}) using the following equation:



City of Berea, KY Stormwater Best Management Practices

Design Procedure

Where:

EWQ = the WQv pool elevation (feet)

EPermPool = the permanent pool elevation (feet) at the invert of the water quality orifice.

- Calculate the required orifice cross-sectional area indirectly by using the orifice equation.

$$\sqrt{2g}$$

Where:

C = the orifice coefficient (0.6 is typically used, but not apply for all cases) AWQ = the orifice area (square feet)

g = gravitational acceleration (32.2 feet/s²)

- Calculate the control for the 25-year, 24-hour runoff peak flow (Qp25). The calculation procedures will be similar to those used for the low flow orifice except that any higher outflow openings (i.e., perforated riser openings, weir, orifices, etc.) would be included as well. The combined outflow from all openings must be such that the post-development Qp25 does not exceed the pre-development Qp25.
- The combined outflow from the low flow orifice and any higher outflow openings is calculated by adding together the discharges from each structures associated with a given head value and a specified pond water surface elevation.
- Calculate the required control for water quantity management. See Section 2.4.7. At minimum, Qp100 must be able to be safely passed through the pond with 1-2 feet of freeboard below the top of the embankment. Check with local officials and/or state dam safety personnel to determine whether Qp100 may be passed using only a principal spillway, or if a combination of a principal spillway and emergency spillway will be required. If an emergency spillway is required, the spillway type is often a broad-crested weir or similar structure that is not easily obstructed. The combined outflow through all spillway openings is calculated by adding together the discharges for each opening associated with a given head value and a specified water surface elevation.
- Using the determined opening and spillway information, incorporate the outlet structures into the pond design. Keep in mind that the spillway design must also consider using measures such as removable trash racks to prevent the discharge of floating debris.

STEP 8 – Design the spillways and embankments.

- All spillway and embankment design must meet any applicable state and/or local criteria.
- The emergency spillway must be stabilized.



City of Berea, KY Stormwater Best Management Practices

Design Procedure

- The embankments must be overfilled by at least 5% to allow for settling.
- The minimum embankment width is 6 feet. A wider embankment width may be preferred for maintenance access.
- All embankments must be adequately stabilized with appropriate non-woody vegetation or other measures.
- The embankment and spillway side slopes should be no steeper than 1:3 (V:H).
- Using the determined opening and spillway information, incorporate the outlet structures into the pond design. Keep in mind that the spillway design must also consider using measures such as removable trash racks to prevent the discharge of floating debris.

STEP 9 – Design the inlets.

- If inflow inlet pipes are used, it is recommended that the pipes be buried below the frost line.
- Inlet design should consider preventing or reducing scour by including riprap or flow diffusion devices such as plunge pools or berms.

STEP 10 – Design the sediment forebay.

- The sediment forebay size was determined in Step 6.
- The bottom of the forebay may be hardened using concrete, asphalt or grouted riprap to make sediment removal easier.
- The forebay outlets should include non-erosive conditions as flows move from the forebay to the pond.
- The forebay of the pond should include a fixed vertical sediment depth marker securely installed in the forebay. This marker will be used as an indicator for when sediment removal is needed in the forebay. Sediment removal should occur for forebay areas every 2-7 years or after 50% of the total forebay storage capacity is filled with sediment.

STEP 11 – Design the maintenance access and safety features.

- Maintenance access and safety features should meet the requirements included in the Design Criteria and Design Component sections.
- Any additional safety features or signage should be added as appropriate.
- Dam safety regulations must be strictly followed in pond design and maintenance to ensure that downstream property and structures are adequately protected.
- OSHA safety procedures must be followed for maintenance activities in enclosed areas, such as outlet structures.

STEP 12 – Check the expected pond performance against regulatory requirements.

- The pond design should be re-checked to confirm that the pond meets the flow control requirements.



City of Berea, KY Stormwater Best Management Practices

Design Procedure

- The average detention time for WQ_v is 12 hours. The release rate for WQ_v should not exceed 5.66 cfs per acre of pond area.
- Post-development Q_{P25} is no more than the pre-development Q_{P25}.
- If required, post-development Q_{p100} is no greater than the pre-development Q_{p100}.
- If required, the post-development Q_{p100} must be able to be safely passed through the pond while maintaining 1-2 feet of freeboard below the top of the embankment.
- Any other requirements for state dam safety.
- The % TSS removal for the treatment train (upstream water quality BMPs and pond) must be 80% or greater.

STEP 13 – Prepare the vegetation and landscaping plan.

The vegetation and landscaping plan should include soil preparation information, vegetation type and vegetation maintenance. The plan should include information about where woody vegetation is not appropriate (i.e., embankment areas, near spillways where access may be affected, etc.). The plan should also include information about reapplying stabilization measures to areas where vegetation growth is sparse.

STEP 14 – Prepare the operation and maintenance plan.

The operation and maintenance plan should include maintenance information and inspection checklists similar to those discussed in this practice's fact sheet.

STEP 15 – Complete the Design Summary Table.

| Design Parameter | Required Size | Actual Size |
|---------------------------|---------------|-------------|
| Pond Type | | |
| WQ _v | | |
| WQ _v Elevation | | |
| Forebay | | |
| Outlet | | |



**City of Berea, KY
Stormwater Best Management Practices**

3.4 POST CONSTRUCTION STORMWATER CONTROL FACT SHEETS (PTP)

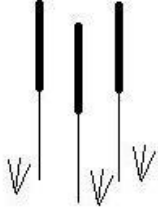
| Post Construction Stormwater Control Practices | 3.4.4 Constructed Wetlands |
|--|--|
|  <p>Symbol</p> <div data-bbox="240 789 412 898" style="border: 2px solid black; padding: 5px; display: inline-block;"> <p>SW</p> </div> |  |
| <p>Description</p> <p>Constructed wetlands are constructed basins that have a pool of water throughout the year (or at a minimum, throughout the wet season). They differ from wet ponds primarily in being shallower and having greater vegetation coverage. They are considered among the most effective stormwater practices in terms of pollutant removal and offer additional benefits in terms of aesthetics, groundwater interaction, and wildlife and vegetative habitat. As stormwater runoff flows through the wetlands, treatment is achieved through settling of particulates in the wetland system and uptake of nutrients and other constituents in the water by vegetation, soil, and biota.</p> <p>Constructed wetlands are best suited to removing contaminants other than sediment from flow. If sediment loads are high, pretreatment is required. Pretreatment options include the use of sediment forebays, filter strips, and construction of a pond upstream of the wetland to remove sediment. The choice of a particular pretreatment option depends on site and hydrologic conditions.</p> <p>A constructed wetland may consist of:</p> <ul style="list-style-type: none"> ➤ Shallow marsh areas of varying depths with wetland vegetation ➤ Permanent micropool at the outlet ➤ Overlying zone in which runoff volumes are stored ➤ A sediment forebay at the inflow(s) ➤ Emergency spillway ➤ Maintenance access ➤ Safety bench ➤ Wetland buffer ➤ Indigenous wetland vegetation and landscaping | |



City of Berea, KY Stormwater Best Management Practices

Applications

- Constructed wetlands are recommended for the following locations:
 - Small outfalls with soil conditions that will support the establishment and growth of wetland vegetation.
 - Large industrial and commercial sites with enough space and soil conditions favorable towards the establishment and growth of wetland vegetation.
 - Adjacent to greenways, parks, and recreational areas or other locations amenable towards the promotion of wetland vegetation.
 - Residential subdivisions of low to moderate density.

- Constructed wetlands are **not** recommended for the following locations:
 - Areas with high sediment loads
 - Where sufficient land is not available of the wetland
 - On sites where wetland hydrology cannot be maintained

Low and high visibility sites are conducive towards the establishment of constructed wetlands, so long as the problem of stagnant or standing water is minimized.

Constructed wetlands are typically installed at the downstream end of the treatment train. Constructed wetland size and outflow regulation requirements can be significantly reduced with the use of additional upstream BMPs. However, when a constructed wetland is constructed, it is likely to be the only management practice employed at a site, and therefore must be designed to provide adequate water quality and water quantity treatment for all regulated storms.



City of Berea, KY Stormwater Best Management Practices

Constructed Wetland Variations



Figure PTP-03- 1 Shallow Wetland

Source, *Stormwater Managers Resource Center*

➤ **Shallow Wetland**

The shallow wetland requires a minimum drainage area of 25 acres. The design requires different areas of shallow and relatively deeper marshes with the deeper portions located at the sediment forebay at the inlet and at the micropool at the outlet. Due to the high surface area to volume ratio, a large amount of land is required to meet the necessary water quality volume.



City of Berea, KY
Stormwater Best Management Practices

**Constructed
Wetland
Variations**

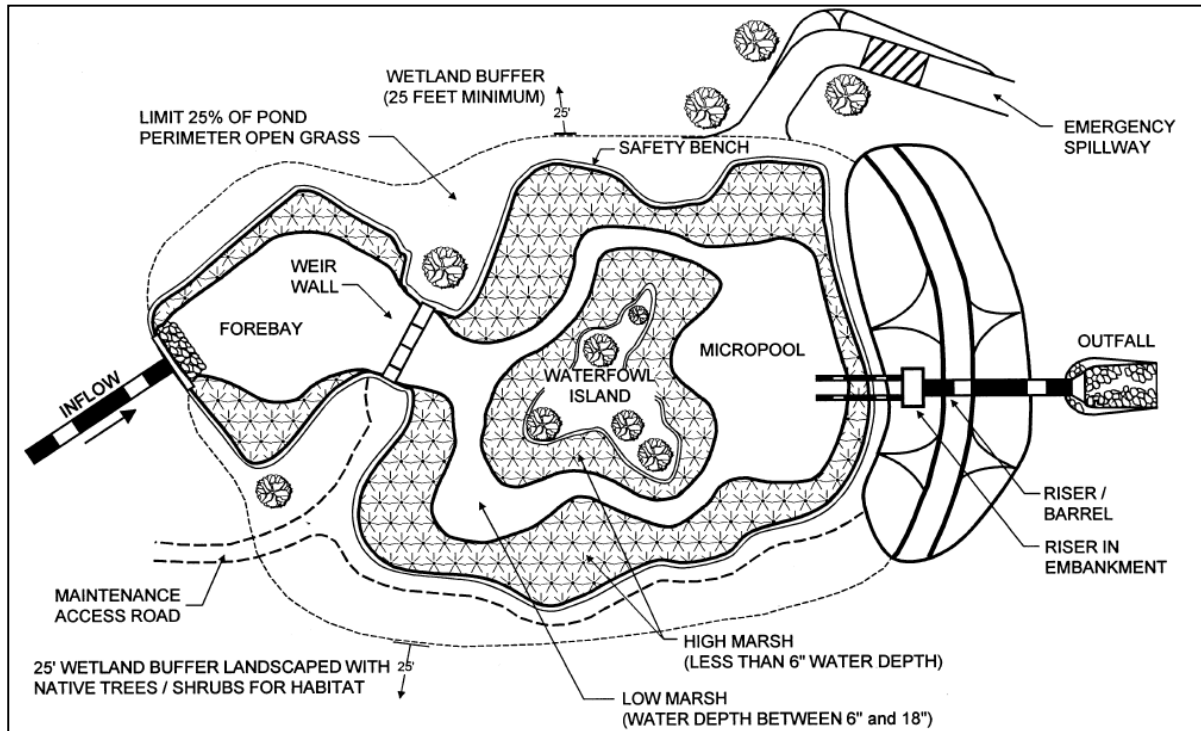

Figure PTP-03- 2 Shallow Wetland
Source, Georgia Stormwater Management Manual

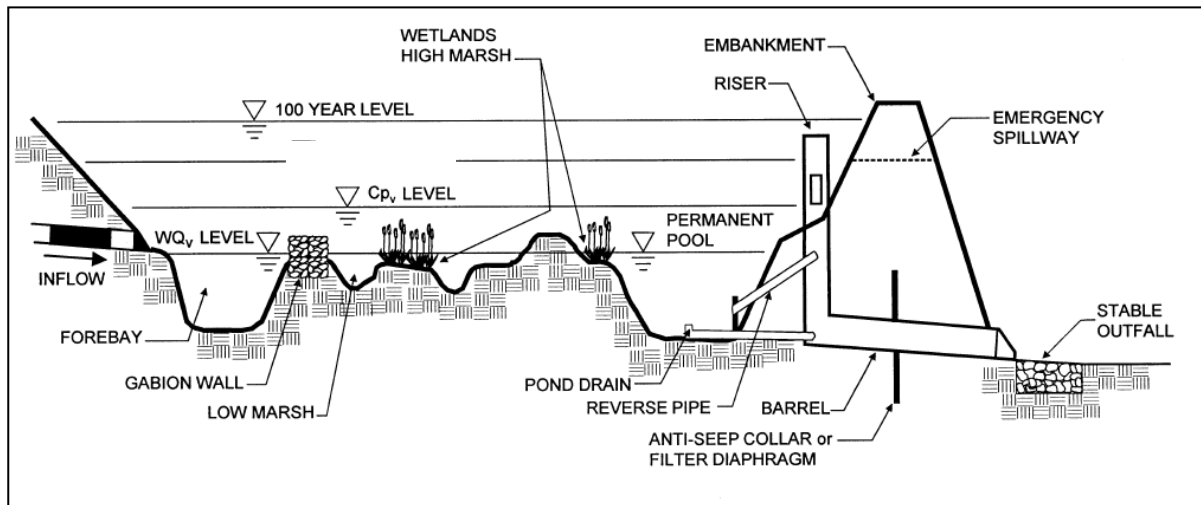

Figure PTP-03- 3 Shallow Wetland
Source, Georgia Stormwater Management Manual



City of Berea, KY Stormwater Best Management Practices

Constructed Wetland Variations



Copyright 2000 Center for Watershed Protection

Figure PTP-03- 4 Pocket Wetland

Source, Stormwater Managers Resource Center

➤ **Pocket Wetland**

The pocket wetland should be used for smaller drainage areas between 5 and 10 acres. The base of the wetland connects to groundwater to maintain a permanent pool, and is typically used in situations where there is not enough drainage area available to maintain a permanent pool. However, the pollutant removal efficiencies for this option are reduced due to the active connection with the water table.



**City of Berea, KY
Stormwater Best Management Practices**

**Constructed
Wetland
Variations**

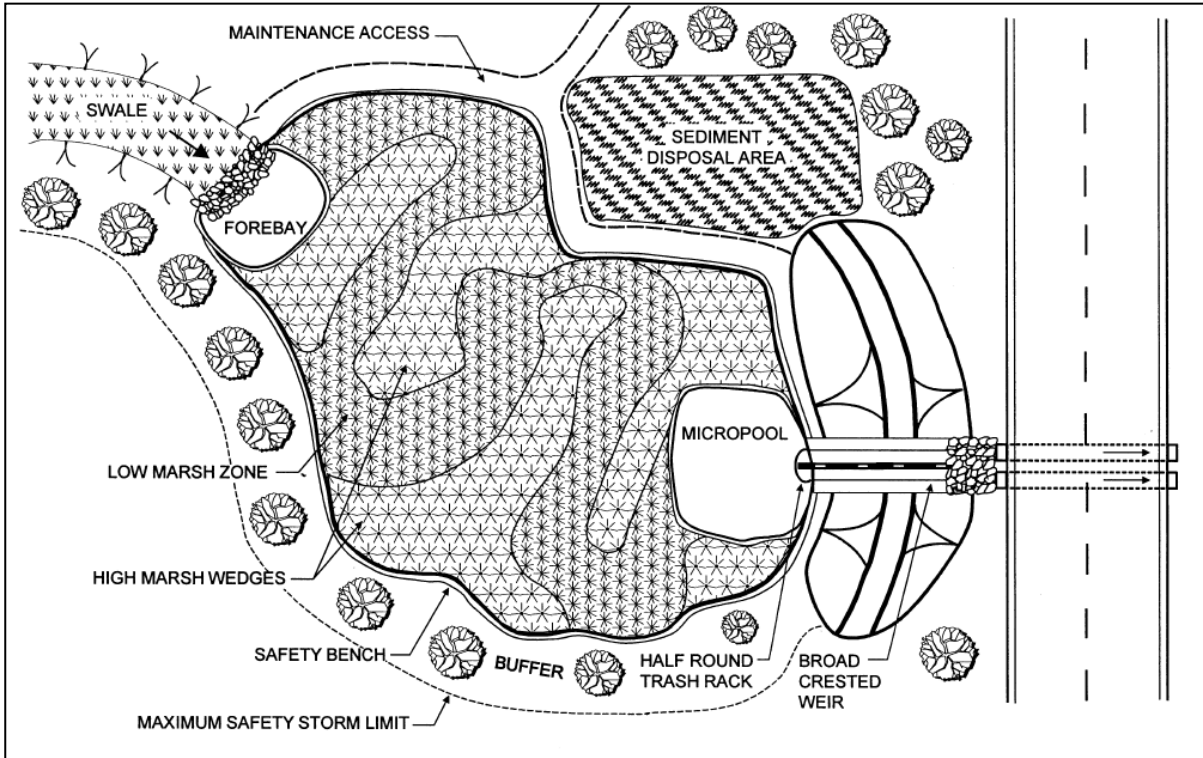

Figure PTP-03- 5 Pocket Wetland
Source, Georgia Stormwater Management Manual

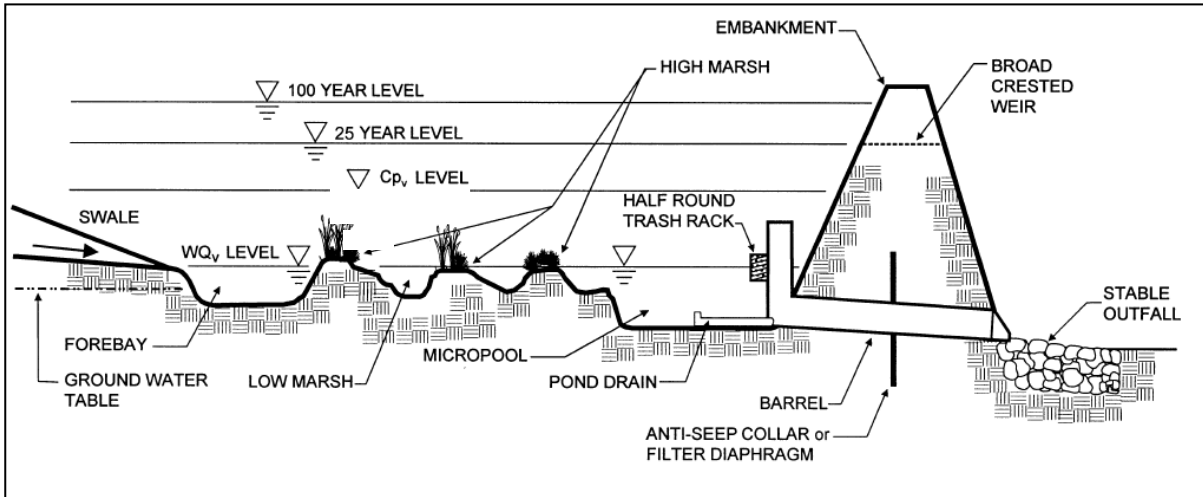

Figure PTP-03- 6 Pocket Wetland
Source, Georgia Stormwater Management Manual



City of Berea, KY Stormwater Best Management Practices

Constructed Wetland Variations



Copyright 2000, Center for Watershed Protection

Figure PTP-03-7 Extended Detention Shallow Wetland

Source, *Stormwater Managers Resource Center*

➤ **Extended Detention (ED) Shallow Wetland**

The extended detention shallow wetland requires a minimum drainage area of 25 acres. The design incorporates additional water quality treatment detention above the surface of the shallow wetland design. The additional storage is typically designed to dewater in a period of 24 hours so that vegetation is not damaged. This design can accommodate sites with limited space by treating in smaller footprint than the shallow wetland. Water quality treatment may be reduced as residence time and contact time with vegetation is also likely to diminish. Landscaping in the extended detention area should incorporate plants tolerant of wet and drought conditions.



City of Berea, KY
Stormwater Best Management Practices

**Constructed
Wetland
Variations**

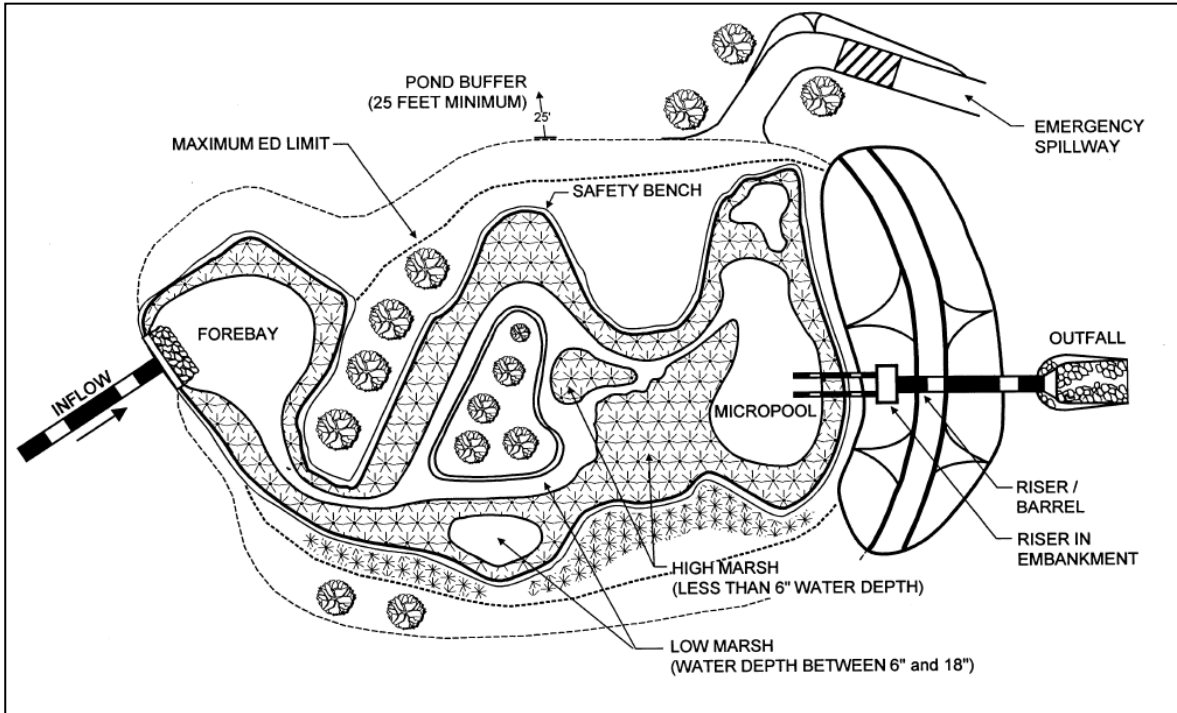

Figure PTP-03- 8 Extended Detention Shallow Wetland
Source, *Georgia Stormwater Management Manual*

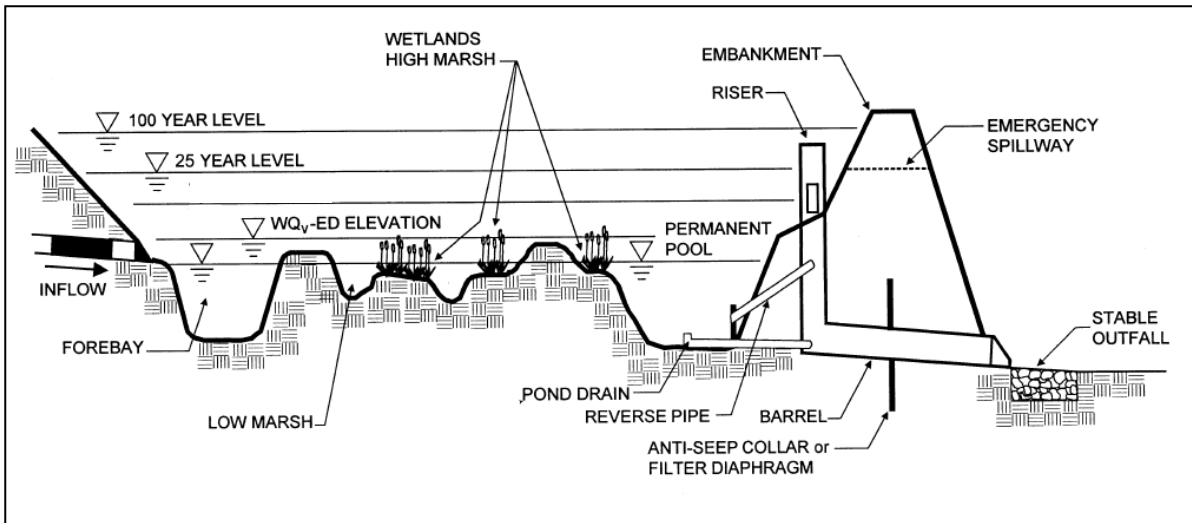

Figure PTP-03- 9 Extended Detention Shallow Wetland
Source, *Georgia Stormwater Management Manual*



City of Berea, KY Stormwater Best Management Practices

Constructed Wetland Variations



Figure PTP-03- 10 Pond/Wetland System

This aerial photo shows a long, narrow pond design connected to the shallow wetland.

Source, *Center for Watershed Protection* [_____](#)

➤ **Pond/Wetland System**

The pond/wetland system requires a minimum drainage area of 25 acres. The design incorporated a wet pond and shallow marsh in order to achieve water quality and quantity goals. Stormwater flows first through the wet pond and then into the shallow wetland. The pond diffuses flows and allows entrained sediment particles to drop out before entering the wetland cell. Similarly to the ED shallow wetland, pond/wetland systems reduce the amount of surface area required compared to a shallow wetland. This is accomplished by the larger storage capacity and increased depth of the pond.



**City of Berea, KY
Stormwater Best Management Practices**

**Constructed
Wetland
Variations**

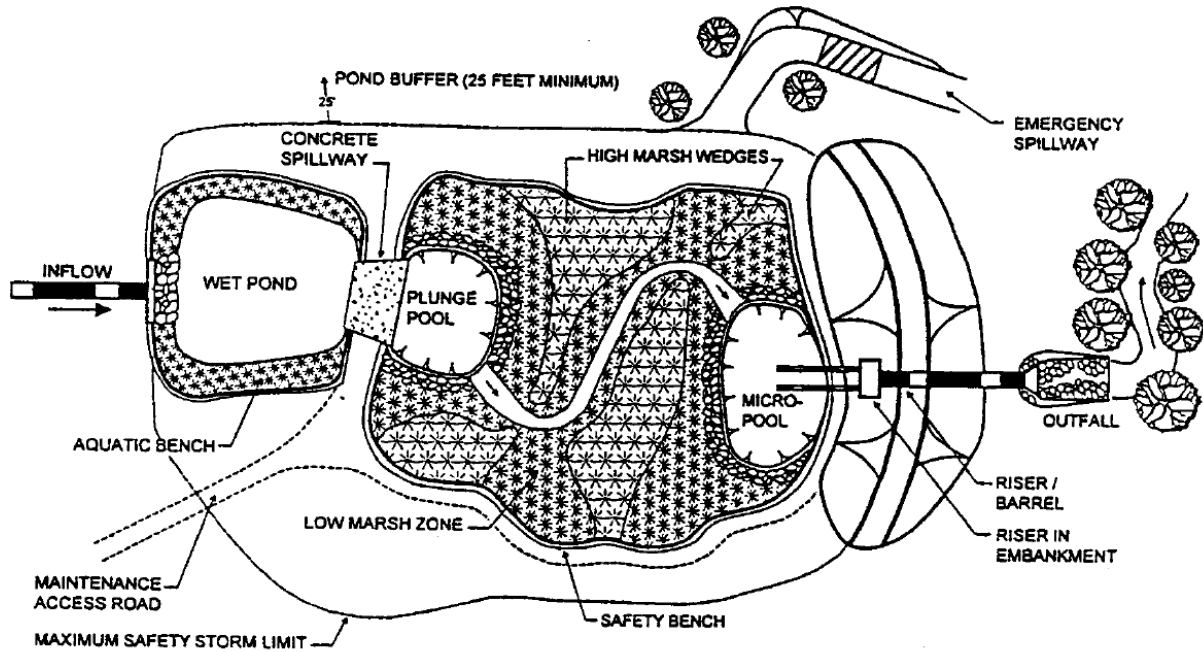

Figure PTP-03- 11 Pond/Wetland System
Source, *Georgia Stormwater Management Manual*

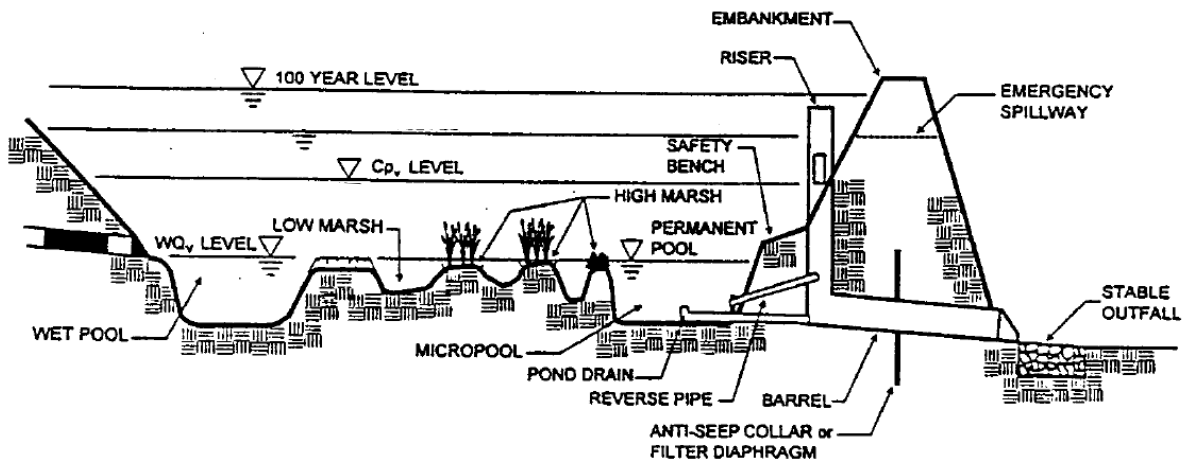

Figure PTP-03- 12 Pond/Wetland System
Source, *Georgia Stormwater Management Manual*



City of Berea, KY Stormwater Best Management Practices

Maintenance

Regular inspections and maintenance are critical to the effective operation of constructed wetlands. Maintenance responsibility for a wetland facility and its buffer should be vested with a responsible authority by means of a legally binding and enforceable maintenance agreement that is executed as a condition of plan approval.

One time Activity

- Replace wetland vegetation to maintain at least 50% surface area coverage in wetland plants after the second growing season.

Monthly to Quarterly or After Major Storms (>1")

- Repair undercut or eroded areas
- Clean and remove debris and trash from inlet and outlet structures.
- Mow side slopes (minimum Spring and Fall).

Semi-Annual to Annual

- Clean and remove debris and trash from wetland.
- Remove invasive vegetation.
- Harvest wetland plants. Remove any harvested vegetation from the wetland.
- Monitor wetland vegetation and perform replacement planting as needed.
- Repair broken mechanical components, if needed.

Every 1 to 3 years

- Repair Pipe and Riser, if needed.
- Forebay maintenance and sediment removal, when needed.

2 to 7 years or after 50% of forebay capacity has been diminished

- Forebay maintenance and sediment removal, when needed.

5 to 25 years or after 25% of wetland volume has been lost

- Remove sediment from main wetland.
- Replace Pipe, if needed.



City of Berea, KY Stormwater Best Management Practices

Inspection Checklist

One time Activity

- Ensure that at least 50% of wetland plants survive.
- Check for invasive wetland plants.

Monthly to Quarterly or After Major Storms (>1")

- Inspect low flow orifices and other pipes for clogging.
- Check the permanent pool area for floating debris, undesirable vegetation.
- Investigate the shoreline erosion.
- Monitor wetland plant composition and health.
- Look for broken signs, locks and other dangerous items.

Semi-Annual to Annual

- Monitor wetland plant composition and health.
- Identify invasive plants.
- Assure mechanical components are functional.

Every 1 to 3 years

- All routine inspection items above.
- Inspect riser, barrel, and embankment for damage
- Inspect all pipes.
- Monitor sediment deposition in facility and forebay.

2 to 7 years or after 50% of forebay capacity has been diminished

- Monitor sediment deposition in facility and forebay.

5 to 25 years or after 25% of wetland volume has been lost

- Remote television inspection of reverse slope pipes, underdrains, and other hard to access piping.



City of Berea, KY Stormwater Best Management Practices

- Design Criteria**
- Constructed wetlands cannot be located within navigable water of the United States without obtaining a Section 404 permit under the Clean Water Act, and any other applicable State permit. Therefore, a 404 permit may be required for this practice.
 - The surface area of a constructed wetland should be about 2% to 4% of the area that drains to them.
 - Constructed wetlands require setbacks from property lines, private wells, and septic system tanks and leach fields.
 - Pretreatment is required for constructed wetlands. Sediment forebays are the typical pretreatment measure.
 - Outlets of inflow channels are to be stabilized with flared riprap aprons, or the equivalent. Inlet pipes to the constructed wetland can be partially submerged.
 - In general, wetland designs are unique for each site and application. However, there are a number of geometric ratios and limiting depths for the design of a constructed wetland that must be observed for adequate pollutant removal, ease of maintenance, the support of wetland vegetation, and improved safety. Table PTP-03-01 provides the recommended physical specifications and geometry for the various constructed wetland design variants.

Table PTP-03- 1 Recommended Design Criteria for Constructed Wetlands
(Modified from Massachusetts DEP, 1997, Schueler, 1992)

| Design Criteria | Shallow Wetland | ED Shallow Wetland | Pond/Wetland | Pocket Wetland |
|--|---|---|---|---------------------------|
| Length:Width (min) | 2:1 | 2:1 | 2:1 | 2:1 |
| Extended Detention (ED) | No | Yes | Optional | Optional |
| Allocation of Permanent Pool and WQ _v Volume (pool/marsh/ED) in % | 25/75/0 | 25/25/50 | 70/30/0 | 25/75/0 |
| Allocation of Surface Area (deepwater/low marsh/high marsh/semi-wet) | 20/35/40/5 | 10/35/45/10 | 45/25/25/5 (includes pond surface area) | 10/45/40/5 |
| Forebay | Required | Required | Required | Optional |
| Micropool | Required | Required | Required | Required |
| Outlet Configuration | Reverse-slope pipe or hooded broad-crested weir | Reverse-slope pipe or hooded broad-crested weir | Reverse-slope pipe or hooded broad-crested weir | Hooded broad-crested weir |

- The required permanent pool volume is 0.5 inches of runoff from the watershed area draining to the wetland.
- Maximum depth of any permanent pool areas should generally not exceed 6 feet.
- The contours of the wetland should be irregular to provide a more natural landscaping effect.



City of Berea, KY Stormwater Best Management Practices

Design Criteria (cont.)

- An emergency spillway shall be included in the constructed wetland design to safely pass flows that exceed the design storm flows.
- A maintenance right of way or drainage easement must be provided to the wetland facility from a public or private road. The practice, as well as all access roads and components of the wetland, must be located in the drainage easement.
- Safety features should be incorporated into the constructed wetland design.

Design Components

- Site Considerations:
 - **Physiographic Factors** - local terrain design constraints
 - Low Relief – Providing wetland drain can be problematic
 - High Relief – Embankment heights restricted per Kentucky Division of Water
 - Karst – Requires poly or clay liner to sustain a permanent pool of water and protect aquifers; limits on ponding depth; geotechnical tests may be required
 - **Soils** – Hydrologic group “A” soils and some group “B” soils may require liner (not relevant for pocket wetland)
 - **Location and Siting** – the following minimum setback are required for constructed wetlands:
 - From a property line – 10 feet
 - From a private well – 100 feet; if well is down gradient from a hotspot land use (ex: gas station) then the minimum setback is 250 feet
 - From a septic system tank/leach field – 50 feet
- Pre-treatment
 - **Sediment Forebay** – a sediment forebay is designed to remove incoming sediment from the stormwater flow prior to dispersal into the wetland.
 - The forebay should consist of a separate cell, formed by an acceptable barrier.
 - A forebay shall be provided at each inlet, unless the inlet provides less than 10% of the total design storm inflow to the wetland facility.
 - The forebay should be sized to contain 10% of the computed wetland permanent pool volume in a pool 4 to 6 feet deep. The forebay storage volume counts toward the total permanent pool volume requirement and may be subtracted from the permanent pool volume for subsequent calculations.



City of Berea, KY Stormwater Best Management Practices

Design Components

- Exit velocities from the forebay must be nonerosive.
- A fixed vertical sediment depth marker should be installed in the forebay to measure sediment deposition over time.
- The bottom of the forebay may be hardened (e.g., using concrete, paver blocks, etc.) to make sediment removal easier.
- **Wetland Buffer** – a buffer works by filtering runoff, trapping sediment, absorbing nutrients, and attenuating high flows. The buffer should be a minimum of 25 feet.
- Treatment
 - **Permanent Pool** – the permanent pool is sized according to the entire area draining to the wetland. The total volume of the permanent pool is 0.5 inches of runoff per acre of drainage area.
 - **Flow Path** – a minimum dry weather flow path of 2:1 (length to width) is required from inflow to outlet across the constructed wetland and should ideally be greater than 3:1. This path may be achieved by constructing internal dikes or berms, using marsh plantings, and by using multiple cells. Finger dikes are commonly used in surface flow systems to create serpentine configurations and prevent short-circuiting. Microtopography (contours along the bottom of a wetland or marsh that provide a variety of conditions for different species needs and increases the surface area to volume ratio) is encouraged to enhance wetland diversity.
 - **Shallow Marsh Areas** – the constructed wetland should be designed with the recommended proportion of “depth zones.” Each of the three wetland design variants has depth zone allocations which are given as a percentage of the constructed wetland surface area. Target allocations are found in Table PTP-03-01.
 - Deepwater zone – From 1.5 to 6 feet deep. Includes the outlet micropool and deepwater channels through the wetland facility. This zone supports little emergent wetland vegetation, but may support submerged or floating vegetation.
 - Low marsh zone – From 6 to 18 inches below the normal permanent pool or water surface elevation. This zone is suitable for the growth of several emergent wetland plant species.
 - High marsh zone – From 6 inches below the pool to the normal pool elevation. This zone will support a greater density and diversity of wetland species than the low marsh zone. The high marsh zone should have a higher surface area to volume ratio than the low marsh zone.
 - Semi-wet zone – Those areas above the permanent pool that are inundated during larger storm events. This zone supports a number of species that can survive flooding.
 - **Micropool** – a 4- to 6-foot deep micropool must be included in the design at the outlet to prevent the outlet from clogging and resuspension of sediments.



City of Berea, KY Stormwater Best Management Practices

Design Components

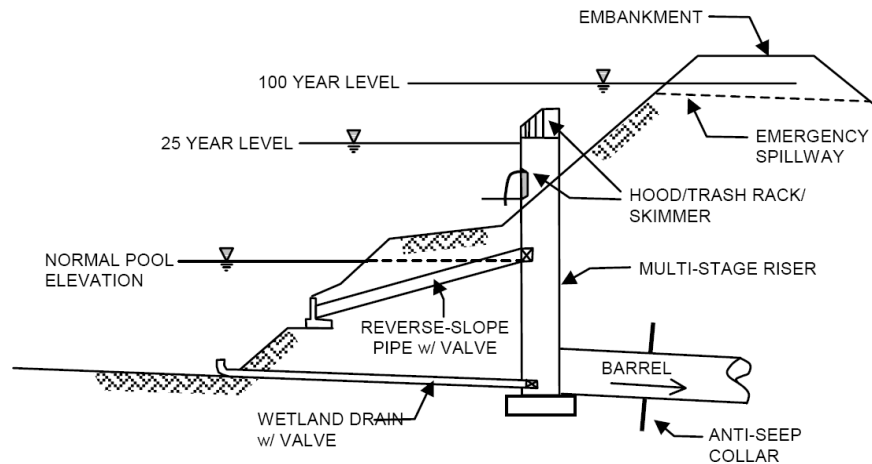

Figure PTP-03- 13 Typical Wetland Facility Outlet Structure
Source: Georgia Stormwater Management Manual

- **Outlet Structures** – Flow control from a constructed wetland is typically accomplished with the use of a concrete or corrugated metal riser and barrel. The riser is a vertical pipe or inlet structure that is attached to the base of the micropool with a watertight connection. The outlet barrel is a horizontal pipe attached to the riser that conveys flow under the embankment (see Figure PTP-04-09). The riser should be located within the embankment for maintenance access, safety and aesthetics. A number of outlets at varying depths in the riser provide internal flow control for routing of the water quality volume (WQ_v), 25 year storm flow (Q₂₅), and 100 year storm flow (Q₁₀₀). Note that the Q₁₀₀ should be routed through the emergency spillway. The number of orifices on the principle spillway can vary and is usually a function of the wetland design.
 - **Shallow Wetlands, Pocket Wetlands & Pond/Wetland Systems**
 - An off-line shallow or pocket wetland providing only water quality treatment can use a simple overflow weir as the outlet structure.
 - For an on-line shallow/pocket wetland the riser configuration is typically comprised of a peak flow outlet, and extreme flood outlet (often a slot or weir).
 - The 25-yr (QP₂₅) peak flow passes through openings or slots protected by trash racks further up on the riser.
 - Alternative hydraulic control methods to an orifice can be used and include the use of a broad-crested rectangular, V-notch, or proportional weir or an outlet pipe protected by a hood that extends at least 12 inches below the permanent pool.



City of Berea, KY Stormwater Best Management Practices

Design Components

- Extended Detention Shallow Wetland
 - For an extended detention shallow wetland the riser configuration is typically comprised of an extended detention outlet (usually an orifice), peak flow outlet, and extreme flood outlet (often a slot or weir).
 - The extended detention outlet is sized to pass the extended detention water quality volume in 24 hours. This volume is surcharged on top of the permanent pool. The preferred design is a reverse slope pipe attached to the riser, with its inlet submerged 1 foot below the elevation of the permanent pool to prevent floatables from clogging the pipe and to avoid discharging warmer water at the surface of the pond.
 - The QP25 passes through openings or slots protected by trash racks further up on the riser.
 - Alternative hydraulic control methods to an orifice can be used and include the use of a broad-crested rectangular, V-notch, or proportional weir, or an outlet pipe protected by a hood that extends at least 12 inches below the normal pool.
- After entering the riser, flow is conveyed through the barrel and is discharged downstream.
 - Anti-seep collars should be installed on the outlet barrel to reduce the potential for embankment failure.
 - Riprap, plunge pools or pads, or other energy dissipaters are to be placed at the outlet of the barrel to prevent scouring and erosion. If a wetland facility daylights to a channel with dry weather flow, care should be taken to minimize tree clearing along the downstream channel, and to reestablish a forested riparian zone in the shortest possible distance.
- The wetland facility must have a bottom drain pipe located in the micropool with an adjustable valve that can completely or partially dewater the wetland within 24 hours.
 - The wetland drain should be sized one pipe size greater than the calculated design diameter. The drain valve is typically a hand wheel activated knife or gate valve. Valve controls shall be located inside of the riser at a point where they will not normally be inundated and can be operated in a safe manner.



City of Berea, KY Stormwater Best Management Practices

Design Components

- **Detention Zone** – the detention zone is the overlying area in which runoff volumes are stored above the permanent pool elevation.
 - The volume of the extended detention must not comprise more than 50% of the total WQ_v .
 - The maximum water surface elevation for extended detention must not extend more than 3 feet above the permanent pool.
 - Storage for larger storm events can be provided above the maximum WQ_v elevation (normal pool or extended detention) within the wetland.
- **Safety Bench** – the perimeter of all deep pool areas (4 feet or greater in depth) should be surrounded by safety and aquatic benches similar to those for stormwater ponds.
- **Emergency spillway**
 - An emergency spillway is to be included in the constructed wetland design to safely pass the 100 year storm, Q_{100} . The spillway prevents the wetland's water levels from overtopping the embankment and causing structural damage. The emergency spillway must be located so that downstream structures will not be impacted by spillway discharges.
 - A minimum of 1 foot of freeboard should be provided, measured from the top of the water surface elevation for the extreme flood to the lowest point of the dam embankment, not counting the emergency spillway.
- **Landscaping** – Indigenous wetland vegetation and landscaping.
 - Vegetation should consist of native species suitable in wetland soil beds, including the following species:
 - Barnyard Grass (*Echinochloa Crusgalli*)
 - Switch Grass (*Panicum Virgatum*)
 - Swamp Milkweed (*Asclepias incarnate*)
 - Giant Cane (*Arundinaria gigantean*)
 - Jewelweed (*Impatiens capensis*)
 - River Oat (*Chasmanthium latifolia*)
 - Deertongue (*Panicum clandestinum*)
 - Boneset (*Eupatorium perfoliatum*)



City of Berea, KY Stormwater Best Management Practices

Design Components

- Safety Features
 - Fencing of wetlands is not generally desirable, but may be required by the City where deemed necessary. A preferred method is to manage the contours of deep pool areas through the inclusion of a safety bench (see above) to eliminate drop-offs and reduce the potential for accidental drowning.
 - The principal spillway opening should not permit access by small children, and endwalls above pipe outfalls greater than 48 inches in diameter should be fenced to prevent a hazard.
- Maintenance Access
 - A maintenance right of way or easement must be provided to the wetland facility from a public or private road.
 - The maintenance access should be at least 12 feet wide, having a maximum slope of no more than 15%, and be appropriately stabilized to withstand maintenance equipment and vehicles.
 - The maintenance access must extend to the forebay, safety bench, riser, and outlet and, to the extent feasible, be designed to allow vehicles to turn around.
 - Access to the riser is to be provided by lockable manhole covers, and manhole steps within easy reach of valves and other controls.



City of Berea, KY Stormwater Best Management Practices

Design Procedures

Step 1 – Make a preliminary judgment as to whether site conditions are appropriate for the use of a constructed wetland, and identify the function of the wetland in the overall treatment system.

- Consider basic issues for initial suitability screening, including:
 - Site drainage area
 - Soils
 - Slopes
 - Space required for wetland
 - Depth of water table
 - Minimum head
 - Receiving waters
- Determine how the wetland will fit into the overall stormwater treatment system.
 - Are other BMPs to be used in concert with the constructed wetland?

○ Will a pond be part of the wetland design and if so, where?
Step 2 – Confirm design criteria, site constraints, and applicability.

- Determine the design criteria that will be used.
- Determine any constraints the site will place on the constructed wetland such as a limited amount of surface area available for treatment
- Determine the TSS reduction provided, using the equations below for weighted TSS reduction, $TSS_{weighted}$, and TSS treatment train, TSS_{train} . The minimum TSS reduction required for the site is 80%.
 - The equation for determining the weighted TSS reduction for a site with multiple outlet points is below.

$$\%TSS_{weighted} = \frac{\sum_n^1 (TSS_1 A_1 + TSS_2 A_2 + \dots + TSS_n A_n)}{\sum_n^1 (A_1 + A_2 + \dots + A_n)}$$

Where TSS_1 is the TSS reduction for the BMP treating area 1, A_1 in acres; TSS_2 is the TSS reduction for the BMP treating area 2, A_2 in acres; etc.

- Where runoff is treated by two or more BMPs in series, the TSS reduction provided is calculated with the following equation for a treatment train:

$$TSS_{train} = A + B - \frac{(A \times B)}{100}$$

Where A is the TSS reduction provided by the first BMP and B is the TSS reduction provided by the next BMP.



City of Berea, KY Stormwater Best Management Practices

Design Procedures

Step 3 – Perform field verification of site suitability.

- If the initial evaluation indicates that a wetland would be a good BMP for the site, it is recommended that a sufficient number of soil borings be taken to ensure that wetland conditions (hydrologic and vegetative) can be maintained after construction. The number of borings will vary depending on size of the site, parent material and design complexity. For example, a design that requires compacted earth material to form a dike will likely require more borings than one without this feature.
- It is recommended that the minimum depth of the soil borings be five feet below the bottom elevation of the proposed bioretention system.
- The field verification should be conducted by a qualified geotechnical professional.

Step 4 – Compute runoff control volumes and permanent pool volume.

- Calculate the Permanent Pool Volume, Water Quality Volume (WQ_v), Q₂₅, and Q₁₀₀. Refer to Appendix B for more information on detention and stormwater quantity management requirements.
 - The required water quality treatment volume is 1.1 inches of runoff from the new impervious surfaces created from the project.
 - The storage volume of other BMPs used upstream of the constructed wetland in the treatment train counts toward the total WQ_v requirement and may be subtracted from it.
 - Determine Water Quality Volume (WQ_v).

$$WQ_v = [P R_v(A)]/12$$

Where:

P = is the average rainfall, (inches)

R_v = 0.05 + 0.009(I), where I is the percent impervious

cover A = the area of imperviousness, (acres)

- Calculate the Permanent Pool Volume.
 - The required permanent pool volume is 0.5 inches of runoff from the drainage area to the wetland.
 - Determine Permanent Pool Volume.

$$V = [(0.5)/A]/12$$

Where:

V = is the permanent pool volume, (acre-ft)

A = total watershed area draining to the wetland,
(acres)



City of Berea, KY Stormwater Best Management Practices

Design Procedures

Step 5 – Perform water balance calculations to ensure sufficient inflows to maintain a constant wetland pool and sustain wetland vegetation during prolonged dry weather conditions.

- Check maximum drawdown during periods of high evaporation and during an extended period of no appreciable rainfall to ensure that wetland vegetation will survive.
- The water balance calculation for a constructed wetland can be expressed as follows:

Where:

V = wetland water volume for the permanent pool (ac-ft)

P = precipitation (ft)

A = area of water surface (ac)

R_o = runoff (ac-ft)

O_f = overflow (ac-ft)

Where $R_v = 0.05 + 0.009(I)$

This wetland water balance is conservative and simplified, assuming the following:

- Assume that the change in volume, ΔV , is zero, meaning the water level in the wetland doesn't change significantly over time.
- There is no inflow from baseflow. This simplification will not apply for wetlands constructed in or intercepting a stream.
- There are no losses from infiltration. An impermeable liner must be used, as a significant portion of the City has karst features, making the maintenance of a permanent pool and wetland areas difficult without the liner.
- There is no loss due to evaporation or evapotranspiration.
- For most designs, the overflow rate, O_f, is zero.

Step 6 – Determine pretreatment volume.

A sediment forebay is provided at each inlet, unless the inlet provides less than 10% of the total design storm inflow to the constructed wetland. The forebay should be sized to contain 10% of the computed wetland permanent pool volume in a pool 4 to 6 feet deep. The forebay storage volume counts toward the total permanent pool volume requirement and may be subtracted from the permanent pool volume for subsequent calculations.

Step 7 – Allocate the remaining permanent pool and WQ_v volumes among marsh, micropool, and ED volumes.

Taking into consideration that 10% of the required permanent pool volume has already been allocated to the sediment forebay; the remaining required volume may be allocated between marsh, micropool, and ED volumes using the recommended criteria from Table PTP-03-01.



City of Berea, KY Stormwater Best Management Practices

Design Procedures

Step 8 – Determine wetland location and preliminary geometry, including distribution of wetland depth zones.

- This step involves initially laying out the wetland design and determining the distribution of wetland surface area among the various depth zones (deepwater, high marsh, low marsh, and semi-wet). A stage-storage relationship should be developed to describe the storage requirements and to set the elevation of the permanent pool, the extended detention volume (if applicable), the Q25, and Q100.
- Things to consider as part of the wetland layout include:
 - Provide maintenance access (12' width for trucks/machinery)
 - Use minimum length to width ratios from Table PTP-03-01

Use allocation of surface area from Table PTP-03-01

Step 9 – Compute extended detention orifice release rate and size.

ED Shallow Wetland: Based on the elevations established in Step 8 for the extended detention portion of the water quality volume, the extended detention orifice is sized to release this volume in 24 hours. The extended detention orifice should have a minimum diameter of 3 inches, and should be adequately protected from clogging by an acceptable external trash rack. A reverse slope pipe attached to the riser, with its inlet submerged one foot below the elevation of the permanent pool, is a recommended design. Adjustable gate valves can also be used to achieve this equivalent diameter.

Step 10 – Calculate Q25 release rate and water surface elevation.

Set up a stage-storage-discharge relationship for the control structure for the water quality and extended detention orifice(s) and the peak flow for the 25-year storm.

Step 11 – Design embankment(s) and spillway(s).

Size emergency spillway, calculate the Q100 water surface elevation, set top of embankment elevation, and analyze safe passage of the Q100.

Step 12 – Investigate potential pond/wetland hazard classification.

The design and construction of stormwater management ponds and wetlands are required to follow the latest version of the State of Kentucky dam safety rules.



Step 13 – Design inlets, sediment forebay(s), outlet structures, maintenance access, and safety features. See Design Components Section.

Step 14 – Prepare Vegetation and Landscaping Plan.

A landscaping plan for the wetland facility and its buffer should be prepared to indicate how aquatic and terrestrial areas will be stabilized and established with vegetation.



3.4 POST CONSTRUCTION STORMWATER CONTROL FACT SHEETS (PTP)

| Post Construction Stormwater Control Practices | 3.4.5 Infiltration Systems |
|---|---|
| <p data-bbox="228 436 305 604"> IS </p> <p data-bbox="228 646 321 678">Symbol</p> <p data-bbox="215 743 360 852"></p> <p data-bbox="188 968 407 995">TSS Reduction: 90%</p> |  |
| <p data-bbox="198 1209 367 1247">Description</p> <p data-bbox="404 1209 1390 1470">Infiltration systems are depressions with no outlet used to detain stormwater for a short period of time until it percolates into the groundwater table. Runoff flows into the system, is stored in the voids between stones and is slowly infiltrated through soil layers. As the stormwater penetrates the underlying soil, chemical, biological, and physical processes remove pollutants. Infiltration systems also provide groundwater recharge and preserve baseflow in nearby streams. Two types of infiltration systems that will be addressed here include: infiltration trenches and infiltration basins.</p> | |



City of Berea, KY Stormwater Best Management Practices

Applications

Infiltration systems can be used to manage stormwater runoff from urban areas, where they can be used to treat sheet flow from impervious areas. Infiltration systems are typically suitable for the following applications:

- Small drainage areas
- Impervious area runoff
- Offline systems
- Areas where removal of suspended solids, pathogens, metals, and nutrients is needed
- Areas determined appropriate by karst & geotechnical evaluations

Infiltration systems may fail due to improper siting, design, construction and/or maintenance. Infiltration systems are **not** suitable for the following applications:

- As an independent treatment mechanism
- Sites with steep slopes
- Sites where runoff from hot spot landuses that could contribute to groundwater contamination
- Sites that may cause water problems to downgrade properties.
- Sites with high sediment or pollutant loads
- Sites with high pesticide or pathogen levels
- Manufacturing or industrial sites
- Sites with combined sewer overflows are not suitable applications for this BMP

Infiltration systems should only be applied to stabilized drainage areas, as heavy sediment loads from construction areas will clog and disable the infiltration media. Likewise, they should not be used in areas where stormwater has the potential for high silt or clay content. High amounts of organic debris may also cause clogging for infiltration systems.

Infiltration systems should typically be designed for off-line use to capture the first flush of runoff. A diversion structure such as a flow splitter or weir may be necessary to separate and route the first flush to the infiltration system for water quality control, and route the remaining stormwater to a water quantity management device downstream. Infiltration systems are most effective when turbulent flow is minimized and the flow is spread uniformly across the filter media.



**Infiltration
Systems
Variations**

Infiltration Trench



Figure PTP-05- 1 Infiltration Trench

Source, Stormwater Managers Resource Center [_____](#)

An infiltration trench is a shallow excavated trench that is backfilled with a coarse stone aggregate allowing temporary storage of runoff in the void space of the material. Discharge of this stored runoff occurs through infiltration into the surrounding naturally permeable soil. An infiltration trench is ideal for linear applications, and is most effective when preceded by a pretreatment measure, such as a swale. Since these practices cannot be designed for stormwater quantity control, another measure must be included in the treatment train such as a stormwater pond.

For an infiltration trench, runoff is conveyed from the pretreatment practice into the trench where it is stored in the voids between pea gravel. Treatment occurs as water seeps through the soil. This practice requires verification of soil permeability and contributes to groundwater recharge. If used without proper pretreatment devices, the longevity of this practice may be less than 5 years. Therefore, infiltration trenches should not be constructed as an independent treatment mechanism. This practice is also not appropriate to serve hotspot landuse applications due to the propensity for groundwater contamination.



Infiltration Systems Variations

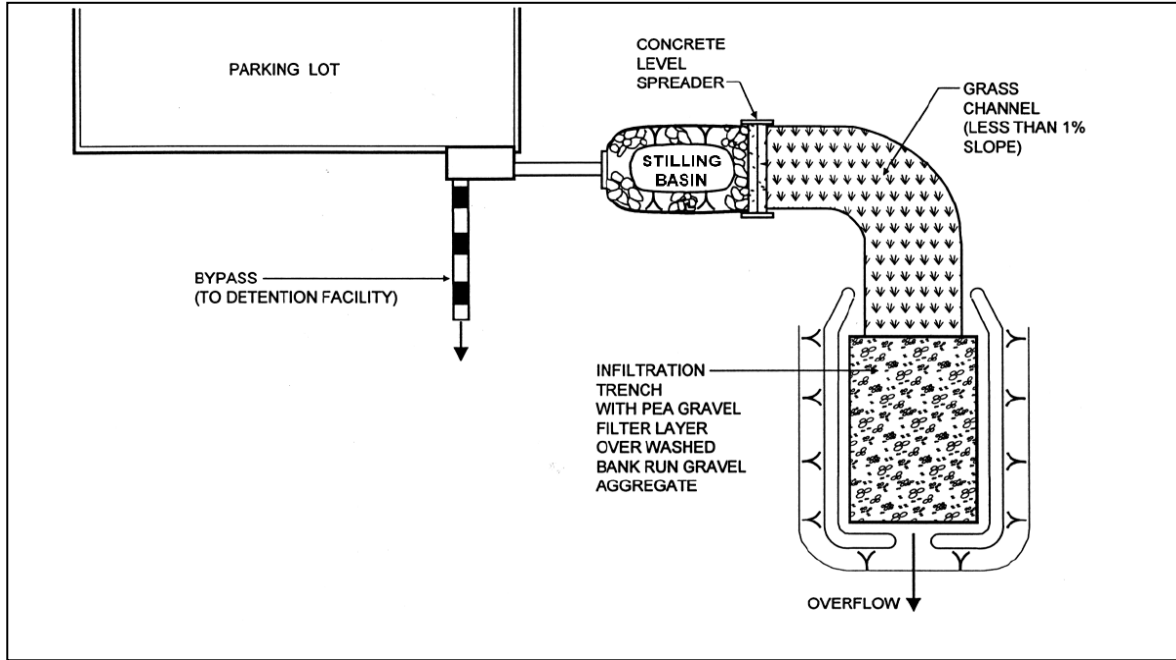

Figure PTP-05- 2 Infiltration Trench
Source: Maryland Stormwater Design Manual

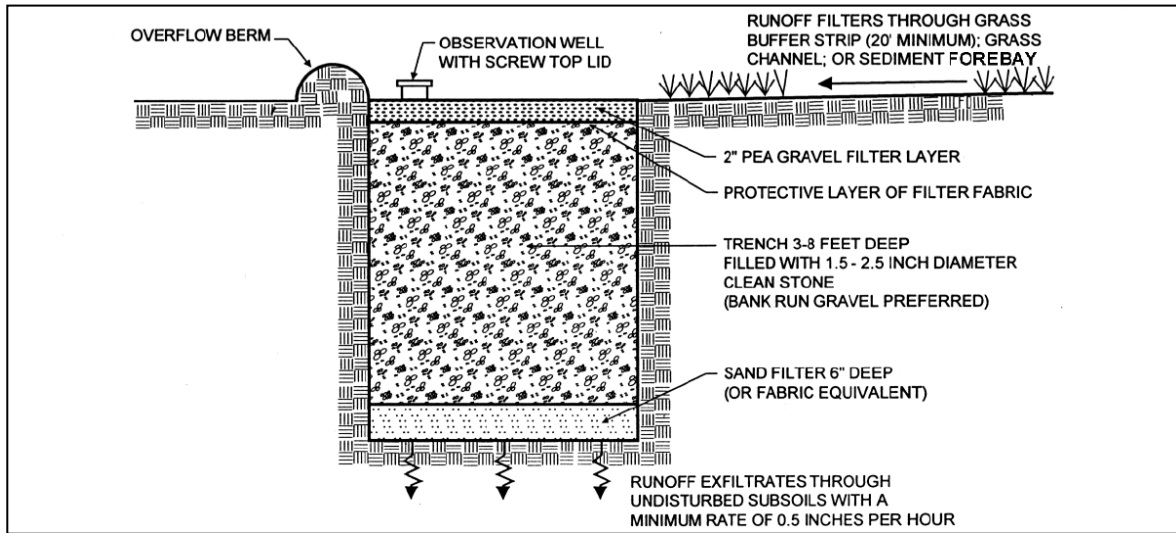

Figure PTP-05- 3 Infiltration Trench
Source: Maryland Stormwater Design Manual



**Infiltration
Systems
Variations**

Infiltration Basin



Figure PTP-05- 4 Infiltration Basin

Source, Stormwater Managers Resource Center [_____](#)

An infiltration basin is a natural or constructed impoundment that captures, temporarily stores and infiltrates the design volume of water over several days. In the case of a constructed basin, the impoundment is created by excavation or embankment. Like the infiltration trench, this practice is most effective when coupled with pretreatment practices such as grass filter strips or grass channels. This practice requires verification of soil permeability and has high maintenance requirements to prevent clogging. Although this practice does not utilize an outlet, a backup underdrain pipe is incorporated to relieve ponded water that has not infiltrated over long periods of time. Drawbacks to the use of infiltration basins are a high failure rate, and frequent maintenance to maintain soil permeability.



Infiltration Systems Variations

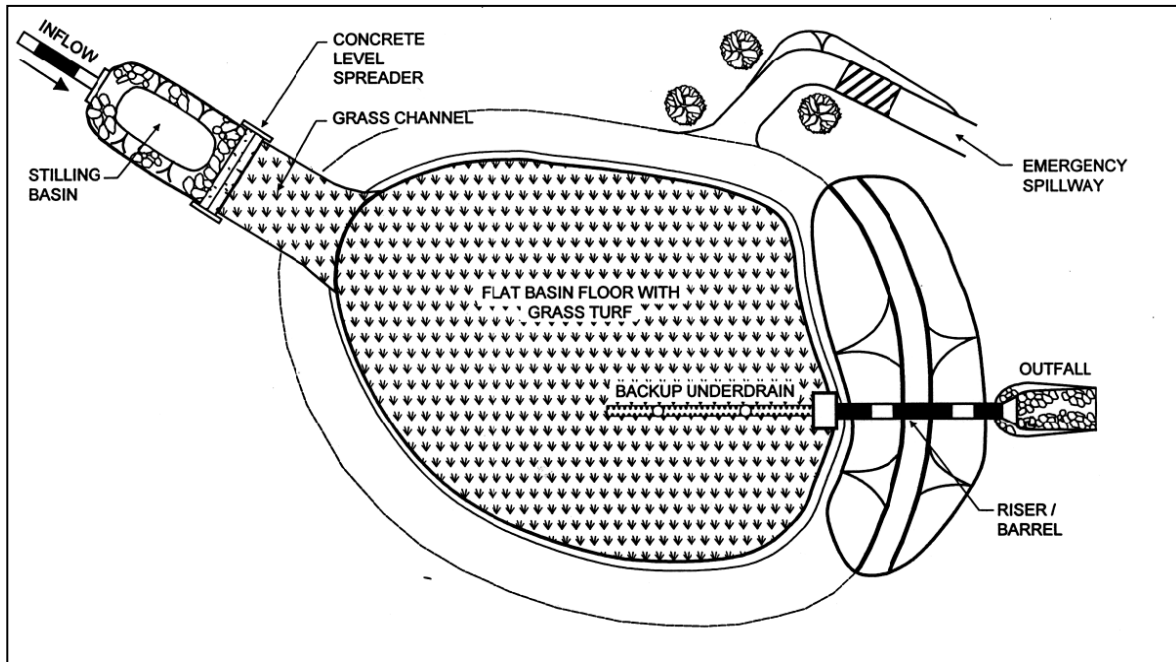

Figure PTP-05-5 Infiltration Basin
Source: Maryland Stormwater Design Manual

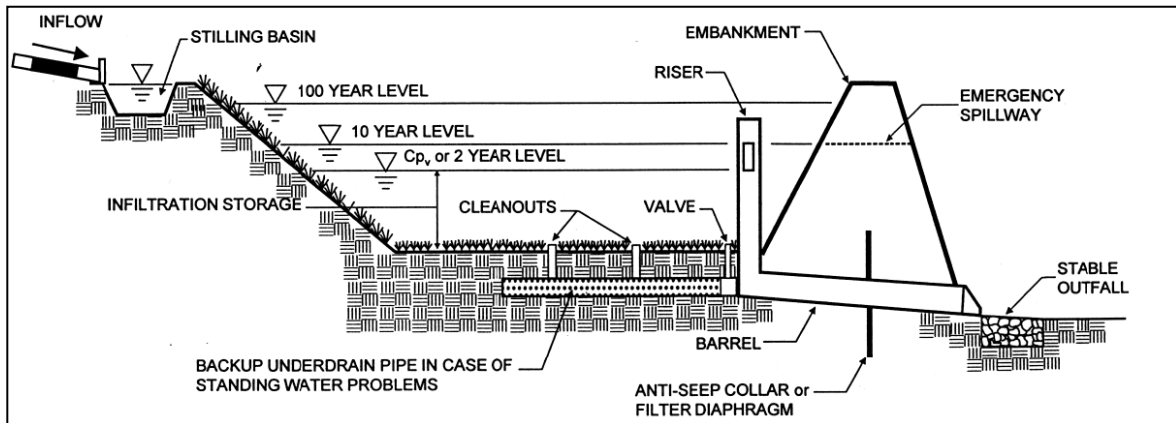

Figure PTP-05-6 Infiltration Basin
Source: Maryland Stormwater Design Manual



City of Berea, KY Stormwater Best Management Practices

Maintenance

When not properly maintained, infiltration systems have a high failure rate. Maintenance and inspections should be conducted regularly to ensure the long term functionality of the system. An observation well should be installed in trenches to determine how quickly it drains after a storm event and to observe sediment buildup.

As-Needed

- Replace pea gravel/topsoil and top surface filter fabric (when clogged).
- Mow grass filter strips and remove grass clippings.

Monthly

- Ensure that contributing area, practice and inlets are clear of debris.
- Ensure that the contributing area is stabilized.
- Remove sediment and oil/grease from pretreatment devices and outflow structures.
- Repair under cut and eroded areas at inflow and outflow structures.

Semi-Annual

- Check observation wells following 3 days of dry weather (failure to infiltrate within this time indicates clogging).
- Inspect pretreatment devices and diversion structures for sediment buildup and structural damage.
- Remove trees that start to grow in the vicinity of the infiltration system.

Annual

- Disc or aerate basin bottom. De-thatch basin bottom.

Every 5-Years

- Scrape basin bottom and remove sediment. Restore original cross-section and infiltration rate. Seed or sod to restore ground cover.
- If bypass capability is available, utilize to provide an extended dry period. This may allow the system to regain the infiltration rate in the short term.

Upon Failure

- Total rehabilitation of the system to maintain storage capacity.
- Excavate trench walls to expose clean soil.



City of Berea, KY Stormwater Best Management Practices

Design Criteria

- The size of the drainage area typically dictates the type of infiltration system. Infiltration trenches have a maximum drainage area of 5 acres. Infiltration basins can work with drainage areas between 5 and 10 acres.
- Sloped areas immediately adjacent to the bioretention system should be no greater than 15%.
- Both types of infiltration systems provide a 90% TSS reduction.
- Pretreatment by other BMPs is required for infiltration systems.
- The sides of infiltration trenches should be lined with a filter fabric that prevents soil piping but has greater permeability than the underlying soil.
- Sheet flow should enter the infiltration system perpendicular to its main axis, and channel flow should enter parallel to the main axis of the direction of flow.
- Underlying soils must be suitable for infiltration.
- Infiltration systems should be constructed with a minimum of 4 feet distance between its base and the seasonally high water table or bedrock to allow for infiltration to occur.
- If a site overlies karst geology, additional geotechnical investigation must be undertaken. The potential for groundwater contamination and sinkhole collapse must be evaluated.
- A porosity value “n” ($n=V_v/V_t$) of 0.40 should be used in the design of stone reservoirs for infiltration systems.
- Design infiltration systems to fully de-water the entire WQ_v within 48 hours after the storm event.
- A conveyance system shall be included in the design of all infiltration systems in order to ensure that excess flow is discharged at non-erosive velocities.
- A dense and vigorous vegetative cover should be established over the contributing pervious drainage area before runoff can be accepted into an infiltration system. Infiltration systems should not be constructed until the contributing drainage area has been completely stabilized.
- Infiltration systems should not be used for a sediment control device during the construction phase.
- Infiltration systems cannot be covered by an impermeable surface.
- Direct access should be provided to all infiltration practices for maintenance and rehabilitation.



City of Berea, KY Stormwater Best Management Practices

Design Components

- **Site** – Infiltration systems may fail due to improper siting, design, construction and/or maintenance.
 - Soils
 - To be suitable for infiltration, underlying soils should have an infiltration rate of 0.52 inches per hour or greater. Initially, soil infiltration rates can be determined from NRCS soil textural classification and subsequently confirmed by field geotechnical tests.
 - The recommended geotechnical testing is one test hole per 5000 square feet, with a minimum of two borings per facility (taken within the proposed limits of the facility).
 - Soils should have a clay content of less than 20% and a silt/clay content of less than 40%.
 - Infiltration systems should not be located in fill soils.
 - Setbacks
 - 50 feet (horizontally) from 20% or greater slopes
 - 100 feet (horizontally) from any water supply well
 - 10 feet down gradient from dry wells
 - 25 feet down gradient from structures
- **Pretreatment** – to ensure the long term effectiveness of infiltration systems, preventative measures should be taken to minimize clogging. Pretreatment is generally most effective when multiple BMPs are placed in series.
 - Before entering an infiltration system, stormwater should first enter a pretreatment practice sized to treat a minimum of 25% of the WQ_v .
 - If the infiltration rate of the underlying soils in the infiltration system treatment area exceeds 2 inches per hour, a pretreatment practice capable of treating a minimum of 50% of the WQ_v should be used.
 - If the infiltration rate of the underlying soils in the infiltration system treatment area exceeds 5 inches per hour a pretreatment practice capable of treating 100% of the WQ_v should be used.
 - To prevent clogging and preserve the long term integrity of the infiltration system treatment area infiltration rate, the following pretreatment BMPs/techniques should be used (at least three per trench and two per basin):
 - Grass filter strips/Grass channel
 - Swale
 - Plunge pool
 - Forebay
 - Bottom sand layer
 - Upper sand layer (6" minimum) with filter fabric at the sand/gravel interface
 - Use of washed bank run gravel as aggregate



City of Berea, KY Stormwater Best Management Practices

Design Components

- To protect groundwater from possible contamination, runoff from designated hotspot land uses or activities should not be infiltrated without proper pretreatment to remove hydrocarbons, trace metals, or toxicants.
- Exit velocities from pretreatment systems should be non-erosive and flows should be evenly distributed across the width of the practice.

Treatment

Design infiltration trenches to handle the WQ_v . Stormwater associated with the larger rainfall events should bypass the infiltration trench.

- Conveyance System
 - A flow splitter or diversion structure should be provided to divert the WQ_v to the infiltration system and the larger flows bypass unless the infiltration system is sized for water quality treatment.
 - When a flow splitter or diversion structure is not used the contributing drainage area for the infiltration system should be limited to the appropriate size given the variation, and an overflow should be provided within the system to pass part of the WQ_v to a stabilized watercourse or storm drain.
 - A natural overland flow path may be used for stormwater runoff exceeding the capacity of the infiltration system. However, it should be evaluated for concentrated flow that may cause erosion. If computed flow velocities do not exceed the non-erosive threshold, the overflow may be accommodated by natural topography.
- Infiltration Trenches – range from 2 to 10 feet deep and less than 25 feet wide, with a maximum of 3:1 (H:V) side slopes. The bottom of the infiltration trench should be flat, in order to enable even distribution and infiltration of stormwater. The longitudinal slope may vary from 0% to 1%, while the lateral slopes should be held at 0%. Fill the infiltration trench with a 6" layer of sand and coarse stone aggregate. Install filter fabric to separate the sand layer and coarse aggregate. Infiltration trenches are less conducive to site aesthetics.
 - Observation Well – install an anchored 6 inch diameter perforated PVC pipe with a lockable cap in infiltration trenches to monitor the water level and drawdown time. The pipe should be flush with the bottom of the trench.
- Infiltration Basins – range from 3 to 12 feet deep with a maximum of 3:1 (H:V) side slopes. The bottom of infiltration basin should be flat, in order to enable even distribution and infiltration of stormwater. The longitudinal slope may vary from 0% to 1%, while the lateral slopes should be held at 0%. Infiltration basins should be integrated into the site planning process and aesthetically designed as attractive green space planted with native vegetation.
- Outlet – it is recommended that infiltration systems include dewatering methods in the event of failure. This can be done with an underdrain system that accommodates drawdown. Infiltration basins that are designed for water quality should have a multistage outlet and emergency snillwav



City of Berea, KY Stormwater Best Management Practices

Design Procedures

Compute The following design procedures apply to infiltration trenches and infiltration basins.

Step 1 – Compute runoff control volumes.

- Calculate the Water Quality Volume (WQ_v).

Step 2 – Determine if the development site conditions are appropriate for the use of an infiltration trench.

- Type of development?
- Permeable subsoils?
- Low water table?
- Low sediment load?
- Karst area?

Step 3 – Confirm design criteria and applicability

- Consider any special site-specific design conditions/criteria (Additional Site-Specific Design Criteria and Issues).

Step 4 – Size flow diversion structure, if needed

- A flow regulator (or flow splitter diversion structure) should be supplied to divert the WQ_v to the infiltration trench.
- Size low flow orifice, weir, or other device to pass Q_{wg} .

Step 5 – Size infiltration system.

- The area of the trench can be determined from the following equation:

$$A = (WQ_v) / (nd + kT/12)$$

Where:

A = Surface Area

WQ_v = Water Quality Volume (or total volume to be infiltrated)

n = porosity

d = trench depth (feet)

k = percolation (inches/hour)

T = Fill Time (time for the practice to fill with water), in hours

- A porosity value $n = 0.32$ should be used. All infiltration systems should be designed to fully dewater the entire WQ_v within 48 hours after the rainfall event. A fill time $T=2$ hours can be used for most designs.



City of Berea, KY Stormwater Best Management Practices

Design Procedures

- Infiltration Basins should be sized according to the following:
 - Determine the depth of the infiltration basin.
$$D = i \times t$$

Where:

 - i = infiltration rate, (in/hr)
 - t = maximum drawdown time, (hr)
 - Determine the Effective Infiltration Area of the infiltration basin.
$$A = WQ_v/D$$

Where:

 - A = effective infiltration area at the bottom of the practice, (ft²)
 - WQ_v = Water Quality volume, (ft³)
 - D = maximum depth of practice, (ft)
 - Determine the dimensions of the infiltration basin.
Design the infiltration basin with a 2:1 length to width ratio at the bottom.
 - Determine the volume of the infiltration basin.
$$V = [(A_1 + A_2) / 2] \times D$$

Where:

 - A₁ = Area at bottom of infiltration basin, (ft²)
 - A₂ = Area at top of infiltration basin, (ft²)
 - D = Depth of infiltration basin, (ft)

Step 6 – Determine pretreatment volume and design pretreatment measures.

- A pretreatment practice should be sized to treat a minimum of 25% of the WQ_v.
 - If the infiltration rate of the underlying soils exceeds 2 inches per hour a pre-treatment practice capable of treating a minimum of 50% of the WQ_v should be used.
 - If the infiltration rate of the underlying soils exceeds 5 inches per hour a pre-treatment practice capable of treating 100% of the WQ_v should be used.

Step 7 – Design underdrains, emergency spillway.

- An underdrain system with a drawdown valve should be provided to dewater an infiltration basin for maintenance.
- Infiltration basins that are designed for water quality should have a multistage outlet and emergency spillway.

STEP 8 – Prepare vegetation and landscaping plan

- A landscaping plan for infiltration system should be prepared to indicate how the infiltration system will be stabilized and established with vegetation. The appropriate grass species and wetland plants should be chosen based on the site location, soil type, and hydric conditions.



City of Berea, KY
Stormwater Best Management Practices

Design Procedures

STEP 9 – Complete the Design Summary Table.

| Design Parameter | Required Size | Actual Size |
|--------------------------|----------------------|--------------------|
| Infiltration System Type | | |
| WQ _v | | |
| Pretreatment Type | | |
| Pretreatment Size, V | | |
| Infiltration Rate | | |



**City of Berea, KY
Stormwater Best Management Practices**

**Example
Design**

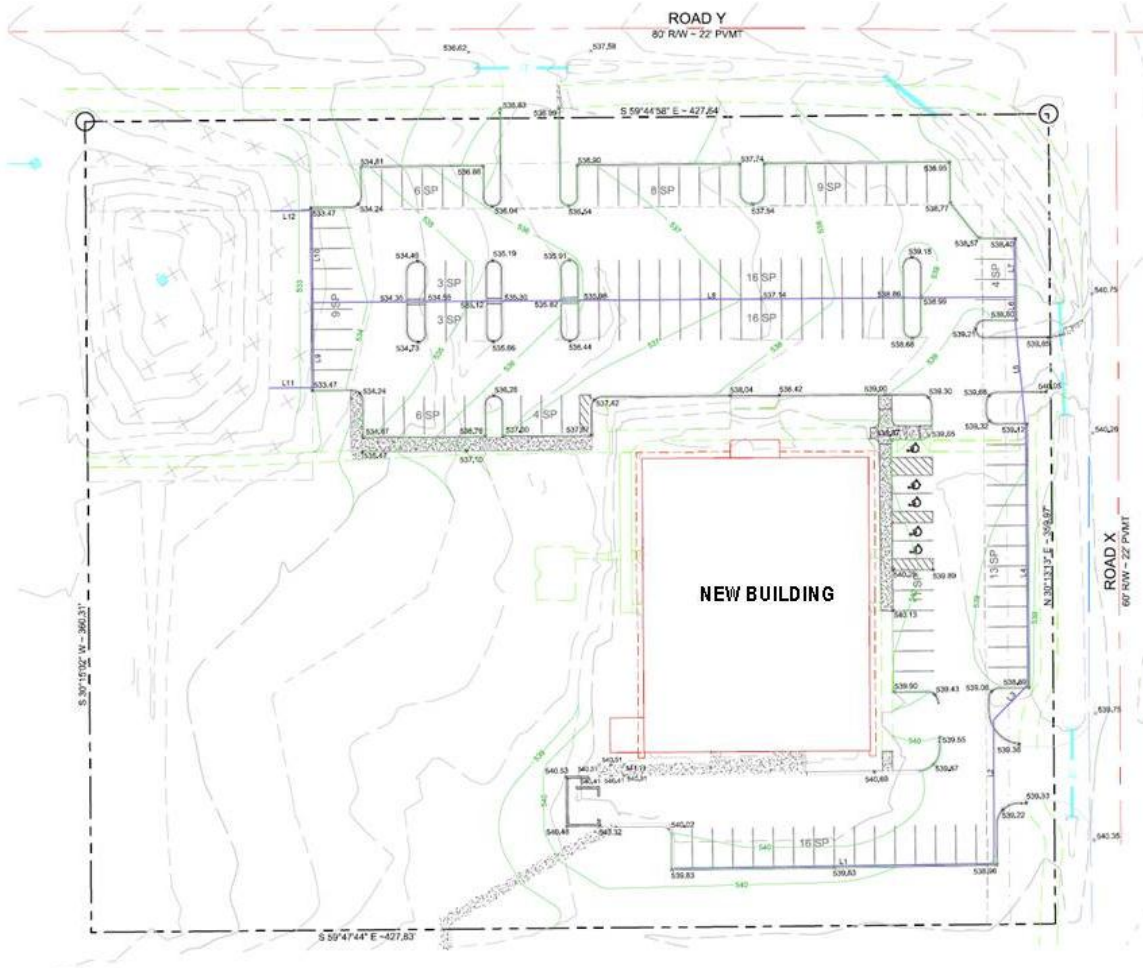

Proposed development of an undeveloped site into an office building and associated parking.

| <p>Base Data Total Drainage area = 5.0 ac Site Area = 3.54 ac Soils Type "C"</p> <p>Pre-Development Impervious Area = 0 ac; or I = 0% Meadow (CN = 71)</p> <p>Post-Development Impervious Area = 1.72 ac; or I = 1.72/3.54 = 49% Open Space, Fair (CN = 79) Paved parking lots, roofs, driveways, etc. (CN =98)</p> | <p>Hydrologic Data</p> <table border="1"> <thead> <tr> <th></th> <th>Pre</th> <th>Post</th> </tr> </thead> <tbody> <tr> <td>CN</td> <td>71</td> <td>89</td> </tr> </tbody> </table> <p>WQ_v Depth = 1.1 in</p> <p>Precipitation</p> <table border="1"> <thead> <tr> <th></th> <th>2.45 in/hr</th> </tr> </thead> <tbody> <tr> <td>l_{wq}</td> <td>2.45 in/hr</td> </tr> <tr> <td>2yr, 24hr</td> <td>3.54 in</td> </tr> <tr> <td>25yr, 24hr</td> <td>5.88 in</td> </tr> <tr> <td>100yr, 24hr</td> <td>7.43 in</td> </tr> </tbody> </table> | | Pre | Post | CN | 71 | 89 | | 2.45 in/hr | l _{wq} | 2.45 in/hr | 2yr, 24hr | 3.54 in | 25yr, 24hr | 5.88 in | 100yr, 24hr | 7.43 in |
|--|--|------|-----|------|----|----|----|--|------------|-----------------|------------|-----------|---------|------------|---------|-------------|---------|
| | Pre | Post | | | | | | | | | | | | | | | |
| CN | 71 | 89 | | | | | | | | | | | | | | | |
| | 2.45 in/hr | | | | | | | | | | | | | | | | |
| l _{wq} | 2.45 in/hr | | | | | | | | | | | | | | | | |
| 2yr, 24hr | 3.54 in | | | | | | | | | | | | | | | | |
| 25yr, 24hr | 5.88 in | | | | | | | | | | | | | | | | |
| 100yr, 24hr | 7.43 in | | | | | | | | | | | | | | | | |



City of Berea, KY Stormwater Best Management Practices

Example Design

This example focuses on the design of an infiltration basin to meet the water quality control requirements. This example design focuses on water quality volume (WQ_v) control only. However, similar design procedures would be used to design for the other water quantity control requirements.

Problem: Design an infiltration basin for this site. Infiltration basins provide 90% TSS reduction. Therefore, no other water quality treatment BMPs will be needed for this site. The total drainage area to the pond is 5 acres, which includes offsite drainage.

Step 1 – Compute runoff control volumes

Total Site WQ_v:

$$WQ_v = [(P R_v)(A)]/12$$

Where:

$$P = 1.1 \text{ inches}$$

$$R_v = 0.05 + 0.009(I)$$

$$I = 49$$

$$R_v = 0.05 + 0.009(49) = 0.491$$

$$A = 1.72 \text{ acres}$$

$$WQ_v = (1.1 \text{ in} \times 0.491 \times 1.72 \text{ ac})/12 = 0.077 \text{ acre-ft} = 3373 \text{ ft}^3$$

Step 2 – Determine if the development site conditions are appropriate for the use of an infiltration trench.

- The landuse for the development is not considered a hotspot landuse.
- High levels of pesticides, sediment, and other pollutant loads are not anticipated.
- Based upon soil borings, the high water table level is 15 feet below the ground surface, and the clay content is 12%. The silt/clay content is 38%.
- Geotechnical reports found no active karst features on the site.
- There are no water supply or dry wells within 100 ft.



City of Berea, KY
Stormwater Best Management Practices

Example Design

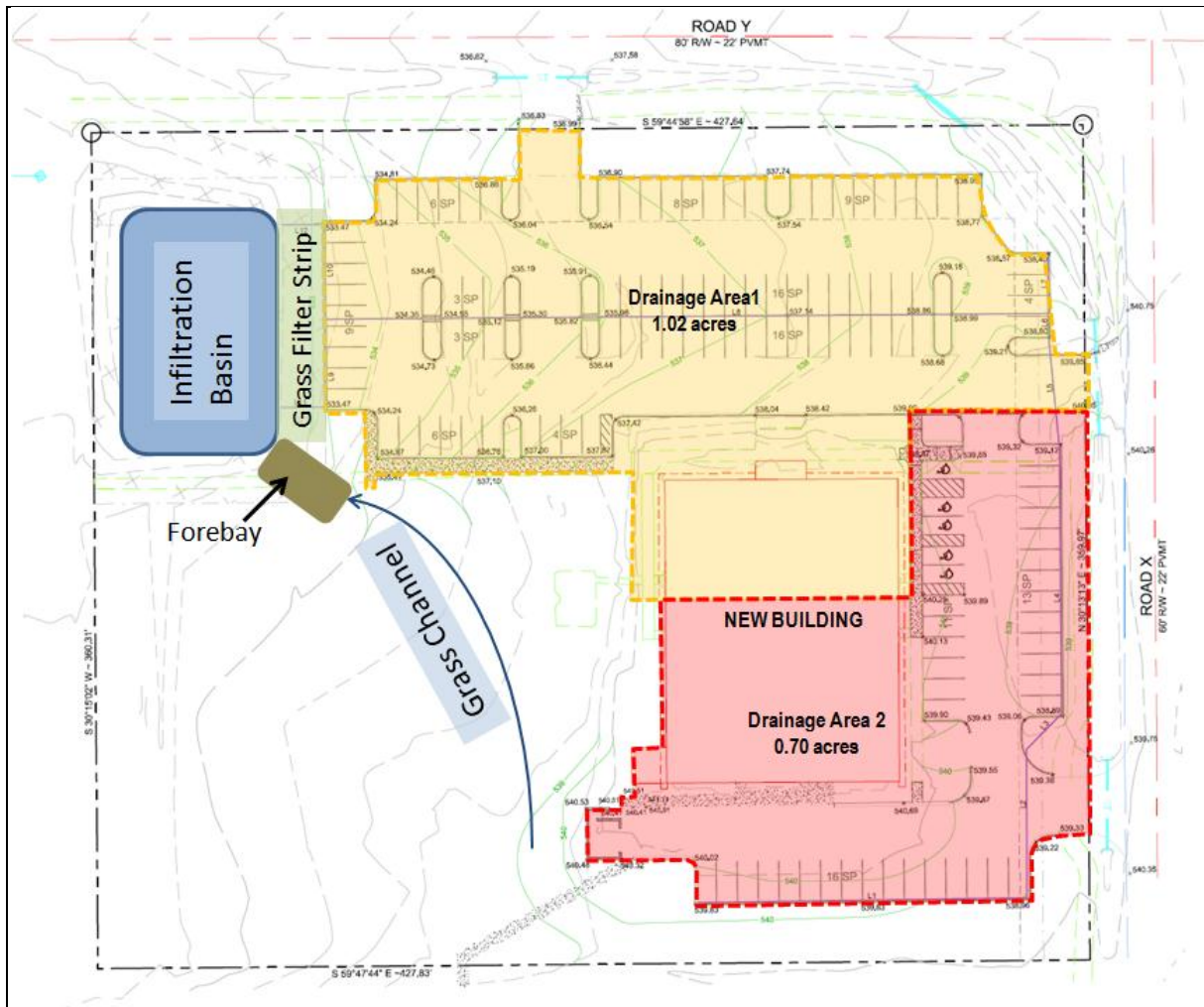

Step 3 – Confirm design criteria and applicability

- Underlying soils on this site have an infiltration rate of 0.6 in/hr.
- A sediment forebay will be included and designed for 25% of WQ_v
- A grass lined channel will convey runoff from drainage area 2 to the forebay and infiltration basin. A flow diversion will be incorporated into the channel design to bypass larger storm events. The infiltration basin is only being designed for stormwater quality.
- A grass filter strip will provide pretreatment for drainage area 1.

Step 4 – Size flow diversion structure, if needed

Since the infiltration basin will only treat the water quality volume, a diversion structure will be placed in the grass channel to bypass the flows in excess of WQ_v to the water quality treatment BMP.



City of Berea, KY Stormwater Best Management Practices

Example Design

Step 5 – Size infiltration basin.

- The infiltration basin will have 3H:1 side slopes.
- Determine the depth of the infiltration basin.

$$D = i \times t$$

Where:

i = infiltration rate, (in/hr)

t = maximum drawdown time, (hr)

$$D = (0.6 \text{ in/hr}) \times (48 \text{ hr}) = 28.8 \text{ in} = 2.4 \text{ ft}$$

- Determine the Effective Infiltration Area of the infiltration basin.

$$A = WQ_v / D$$

Where:

A = effective infiltration area at the bottom of the practice, (ft²)

WQ_v = Water Quality volume, (ft³)

D = maximum depth of practice, (ft)

$$A = (3373 \text{ ft}^3) / (2.4 \text{ ft}) = 1406 \text{ ft}^2$$

- Determine the dimensions of the infiltration basin.

Design the infiltration basin with a 2:1 length to width ratio at the bottom. The basin will be 54 ft long and 27 ft wide. The top and bottom dimensions are generally the same.

- Determine the volume of the infiltration basin.

$$V = [(A_1 + A_2) / 2] \times D$$

Where:

A_1 = Area at bottom of infiltration basin, (ft²)

A_2 = Area at top of infiltration basin, (ft²)

D = Depth of infiltration basin, (ft)

- $V = [(1458 \text{ ft}^2 + 1458 \text{ ft}^2) / 2] \times 2.4 \text{ ft} = 3499.2 \text{ ft}^3 > 3373 \text{ ft}^3 \checkmark$



City of Berea, KY Stormwater Best Management Practices

Example Design

Step 6 – Determine pretreatment volume and design pretreatment measures.

- A sediment forebay will be added at the end of the grass channel prior to the WQ_v entering the Infiltration Basin.
- Determine WQ_v conveyed by grass channel.

$$WQ_v = [(P R_v)(A)]/12$$

Where:

$$P = 1.1 \text{ inches}$$

$$R_v = 0.05 + 0.009(I)$$

$$I = 49$$

$$R_v = 0.05 + 0.009(49) = 0.491$$

$$A = 0.70 \text{ acres for DA2}$$

$$WQ_v = (1.1 \text{ in} \times 0.491 \times 0.70 \text{ ac})/12 = 0.032 \text{ acre-ft} = 1394 \text{ ft}^3$$

- Verify percentage of WQ_v .

$$\%WQ_v \text{ pretreated} = (1394 \text{ ft}^3 / 3373 \text{ ft}^3) \times 100 = 41.3\% > 25\% \checkmark$$

- Determine Area of the forebay. Set the forebay depth at 3 ft

$$A = V/D$$

Where:

$$A = \text{Area of forebay, (ft}^2\text{)}$$

$$V = \text{Pretreatment Volume, (ft}^3\text{)}$$

$$D = \text{Depth of forebay (ft)}$$

$$A = (1394 \text{ ft}^3) / (3 \text{ ft}) = 465 \text{ ft}^2$$

- Determine the dimensions of the forebay.

Design the forebay with a 2:1 length to width ratio at the bottom. The forebay will be 31 ft long 15 ft wide, and 3ft deep, which is 1395 ft³ in storage provided.

Step 7 – Design underdrains, emergency spillway.

- An underdrain system with a 6-inch perforated PVC pipe surrounded by a 12-inch thick gravel layer should be used. The 6-in perforated pipe should be connected to a drawdown valve.
- This infiltration basin is designed to treat the water quality volume only with higher flows bypassing the basin. An emergency spillway is not required.

STEP 8 – Prepare vegetation and landscaping plan

- The infiltration basin will have a grass lining.



City of Berea, KY
Stormwater Best Management Practices

Example Design

Step 9 –Complete the Design Summary Table.

| Design Parameter | Required Size | Actual Size |
|--------------------------|---|---|
| Infiltration System Type | Basin | |
| WQ _v | 3373 ft ³ | |
| Pretreatment Type | Pretreatment 1: grass filter strip: no design Pretreatment 2: forebay (25% WQ _v): 1394 ft ³ | Pretreatment 1: no design Pretreatment 2: 1395 ft ³ |
| Pretreatment Size, V | 3373 ft ³ | 3499.2 ft ³ |
| Infiltration Rate | 0.6 in/hr | 0.6 in/hr |



City of Berea, KY
Stormwater Best Management Practices

3.4 POST CONSTRUCTION STORMWATER CONTROL FACT SHEETS (PTP)

Post Construction Stormwater Control Practices

3.4.6 Water Quality Units

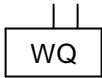

Symbol



TSS Reduction:
Pretreatment: 50%
Full treatment: Varies



Description

Water quality units target pollutants from urban areas or hotspots and provide water quality benefits at stormwater inlets. Units are generally designed as compact below grade systems constructed of precast concrete. Units often employ a swirling motion or baffling that causes sediments and particulates to settle out and a chamber to capture floatable material. Water quality units included here are hydrodynamic separators, filtration units, and continuous deflection separators.

Hydrodynamic separators are flow-through systems with a separation cylinder unit to promote the settlement of sediments and other pollutants. No outside power source is required as the system is designed to utilize the energy of flowing water. Means of separation vary between hydrodynamic separator units, which may employ velocity reduction to allow settling or indirect filtration.

Filtration units are devices inserted into storm drains to filter or absorb sediment, pollutants and oil and grease. Filter media cartridges are commonly used to collect and dispose of pollutants.

Continuous deflection separators treat runoff by screening sediment and debris via a vortex of water that deflects sediment and debris into a sump while water flows through a screen.



City of Berea, KY Stormwater Best Management Practices

Applications

Water quality units work well in areas targeting floatables, grass solids, oils and grease. Water quality units are most suitable for highly impervious sites. Because of their limited removal ability of soluble pollutants and fine particles, these devices should be used as a pretreatment device, and should not act as a stand-alone practice for new development. However, when space is limited, water quality units are ideal for retrofit applications. Site types may include automotive lots, parking lots, roadways, road salt storage facilities, hazardous substance facilities and rooftop runoff.

Water quality units are typically suitable for the following applications:

- Impervious area runoff
- Retrofit applications
- In conjunction with other stormwater BMPs

Target Pollutants

Target pollutants and removal effectiveness may vary widely between the unit type and manufacturer. If available, independent data should be used to consider a water quality unit brand or manufacturer. Independent studies suggest that water quality units primarily target litter and debris with limited pollutant removal capacity, particularly for fine particles and soluble pollutants. Target pollutant information for this fact sheet was based on data from the Environmental Protection Agency's fact sheet, *Manufactured Products for Stormwater Inlets*, referencing S.S. Greb and R. Waschbusch's study, "Evaluation of Stormceptor® and multi-chamber treatment train as urban retrofit strategies", 1998. This study investigated 45 precipitation events over a 9-month period and calculated percent removal rates to reflect overall efficiency, accounting for pollutants in bypassed flows.

Design Components

➤ Hydrodynamic Separators

Hydrodynamic separators are generally considered flow-through devices that promote settling or separation to remove sediment and other pollutants by a swirling action. These structures do not require outside power sources, and become effective through the energy of flowing stormwater. These units are typically placed beneath parking lots or streets, and are directly connected to impervious areas.

➤ Filtration Units

Filtration units employ some type of filter media that collects stormwater pollutants as water flows through the structure. The filter media must be regularly replaced to allow pollutant removal to continue effectively.

➤ Continuous Deflection

The sizing and design for water quality units should be based on the manufacturer's product specifications. Units are generally designed according to the peak flow rate for a given design storm event at the inlet. Units may have features designed to reduce the velocity of the stormwater flow entering the unit, which increases the capacity of sediment removal of the system.



City of Berea, KY Stormwater Best Management Practices

Maintenance

Maintenance instruction should be obtained from the manufacturer to maintain the pollutant removal effectiveness of water quality units. Water quality units are reliable and relatively low maintenance systems due to their design with no moving parts. Maintenance is primarily needed to clean the system of debris and pollutants to keep it working properly. When not properly maintained, water quality units have a high failure rate.

Maintenance and inspections should be conducted regularly after storm events to ensure the long term functionality of the system. By inspecting the unit before and after a significant rain event, the amount and the types of materials being captured can be monitored. This practice can aid in scheduling maintenance based on physical observation and attention to rainfall frequency. Consideration should also be placed on droughts or dry periods, where accumulation of pollutants can build up and create large amounts of floatables, debris, sediment, oils, hydrocarbons, and other pollutants during first-flush events.

Access to manholes should be clear and unobstructed to allow maintenance to the unit.

Semi-Annual Inspection

- Inspect unit for sediment buildup and structural damage

Routine Maintenance

- Remove sediment and debris from unit via vacuum truck, sump vac or other means.
- Increase maintenance schedule to remove debris during heavy leaf fall or other seasonal accumulation of trash or debris.
- Inspect after significant rainfall events to see if maintenance is needed.



City of Berea, KY Stormwater Best Management Practices

Design Guidance

Section 2.7 outlines the criteria and approval process for proprietary or manufactured BMPs within the City limits. Where the water quality unit is not rated for full treatment (80% TSS reduction), additional permanent treatment practices are required. Water quality units are not typically designed for stormwater quantity control as well, so a detention structure such as a detention pond will be required.

For water quality units designed based upon a flow rate, the following equation must be used to simulate treatment of the WQ_v:

$$Qp = C * I * A$$

Where:

Q_p = the peak flow through the proprietary BMP in cfs

C = runoff coefficient

I = rainfall intensity, 2.45 in/hr

A = the contributing drainage area for the BMP, in acres

Maintenance

A maintenance and operation plan must be provided for each water quality unit. This information can be provided by the manufacturer and must address the following items:

- Expected clean out frequency
- Unit life expectancy
- Procedures addressing dewatering of the unit, should it get clogged
- A cross sectional view of the unit with all overflow structures, weirs, pipe connections clearly identified
- The bypassing mechanism and any maintenance requirements for that component



3.4 POST CONSTRUCTION STORMWATER CONTROL FACT SHEETS (PTP)

| Post Construction Stormwater Control Practices | 3.4.7 Grease Management |
|---|--|
| <p data-bbox="235 485 358 604"></p> <p data-bbox="228 688 321 720">Symbol</p> <p data-bbox="215 814 358 919"></p> |  |
| <p data-bbox="191 1108 365 1144">Description</p> <p data-bbox="191 1549 381 1585">Applications</p> | <p data-bbox="402 1108 1404 1371">Many businesses such as restaurants and food manufacturing generate grease waste during daily operations. The disposal of grease wastes can become a significant source of pollution in streams if not managed properly. Spills, overflows, and leaks occur due to poor maintenance of storage facilities and lack of proper disposal education. This fact sheet addresses proper disposal technique and storage facilities to hold used fats, oils, and grease. In addition to water quality pollution impacts, poor management practices can cause unpleasant odors, attract rodents, and have negative visual effects.</p> <p data-bbox="402 1409 1404 1514">As grease spills may cause potential health risks, grease practices should be approved by the Health Department, and sites should be maintained according to any special operating requirements for food service establishments or grease collection systems.</p> <p data-bbox="402 1549 1404 1734">Grease is generated from several different sources, including meat fats, lard, food scraps, sauces, butter or margarine, shortening, and dairy products. Food service industries such as restaurants should implement grease management and staff education to ensure implementation. Grease management implementation is suitable for the following applications:</p> <ul data-bbox="407 1759 755 1934" style="list-style-type: none">➤ Restaurants➤ Food Preparation Facilities➤ Food Manufacturers➤ Caterers |



City of Berea, KY Stormwater Best Management Practices

Approach

Cover and Contain

In situations where the grease collection dumpster is located outside, overhead cover in the form of a canopy and containment, via a curb system is recommended.

Treat and Discharge

For situations where grease has the potential to be released to the ground, a treat and discharge solution is recommended. This could be accomplished by installing a BMP such as a water quality unit (PTP-06) or another BMP designed to remove oils and greases.

Internal Grease Management

An internal collection system is a closed-loop, grease and oil collection system that utilizes two storage tanks, one each for fresh oil and waste oil. The system directly connects the flow of fresh oil to kitchen oil fryers. Once this oil has been used, the system can directly pump new oil in while the used oil is pumped out. Waste oil and grease is then drained through a filter and to the waste oil storage tank.

Maintenance

A maintenance and operation plan must be submitted for grease management structures that specifically addresses the following items:

- Inspect storage area weekly and following rainfall events
- Repair or replace containment structures, perimeter controls, or storage bin as needed

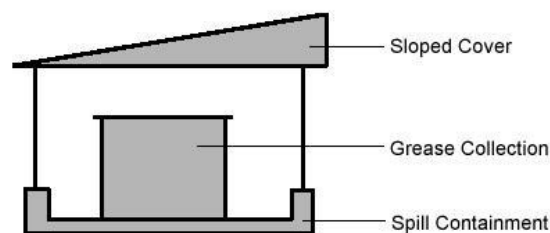

Figure PTP-07- 1 Containment for grease disposal



City of Berea, KY Stormwater Best Management Practices

Management Alternatives

Exterior containment of grease is one management solution, but other management solutions exist. Alternative grease management techniques that are available include internal collection systems (shown in Figure PTP-07-02). These systems, if properly maintained and installed, may be better suited for restaurants or other food preparation facilities that utilize deep fryers or other cooking equipment using large quantities of oil. These systems are often preferred to minimize spills, transfer containers, and related employee injuries.

An internal collection system is a closed-loop, grease and oil collection system that utilizes two storage tanks, one each for fresh oil and waste oil. The system directly connects the flow of fresh oil to kitchen oil fryers. Once this oil has been used, the system can directly pump new oil in while the used oil is pumped out. Waste oil and grease is then drained through a filter and to the waste oil storage tank.

The system is metered by a service provider who monitors need for delivery of new oil and removal of waste oil. This is performed through a pump system and directly transferred to the delivery/removal truck.

Although the City of Bowling Green does not endorse specific brands or products, one example of an internal collection system manufacturer and provider is Restaurant Technologies, Inc. (RTI). More information about RTI products can be found on their website, www.rti-inc.com.





Figure PTP-07- 2 Internal Grease Collection System



**City of Berea, KY
Stormwater Best Management Practices**

3.4 POST CONSTRUCTION STORMWATER CONTROL FACT SHEETS (PTP)

| Post Construction Stormwater Control Practices | | 3.4.8 Dry Detention/Dry ED Ponds | |
|---|---|---|---|
|  <p>Symbol</p>  <p>TSS Reduction: 60%</p> |  | <p>Description</p> | <p>KEY CONSIDERATIONS</p> <ul style="list-style-type: none"> ➤ Applicable for drainage areas up to 75 acres ➤ Typically less costly than stormwater (wet) ponds for equivalent flood storage, as less excavation is required ➤ Often used in conjunction with water quality structural control ➤ Recreational and other open space opportunities between storm runoff events ➤ Typical BMP used in residential landuse <p>Dry detention and dry extended detention (ED) ponds are surface facilities intended to provide for the temporary storage of stormwater runoff to reduce downstream water quantity impacts. These facilities temporarily detain stormwater runoff, releasing the flow over a period of time. They are designed to completely drain following a storm event and are normally dry between rain events. Dry detention ponds are intended to provide overbank flood protection (peak flow reduction of the 25-year storm, Q_{p25}) and can be designed to control the extreme flood (100-year, Q_{p100}) storm event. Dry ED ponds provide Q_{p25} and Q_{p100} control. Both dry detention and dry ED ponds provide limited pollutant removal benefits and are not intended for water quality treatment. Detention-only facilities must be used in a treatment train approach with other structural controls the 80% TSS reduction goal. Compatible multi-objective use of dry detention facilities in strongly encouraged.</p> |



Applications **BMP Suitability**

- Used for residential, commercial and industrial sites
- Large space requirement
- Not well-suited for sites with
 - Low relief
 - High water table
 - Near-surface bedrock
- Safety concerns should be considered in deciding BMP use
- Extended detention ponds can be sized to treat WQ_v.
- Cannot be used alone to meet the 80% TSS reduction goal. Must be used in a treatment train.
- Suitable for a secondary or end-of-pipe BMP at the downstream end of a treatment train.
- This BMP is prone to sediment re-suspension since the pond does not have a permanent pool
- This BMP's performance may be enhanced by using multiple treatment cells in succession.
- Use of upstream BMPs may also reduce the required detention pond size and outflow regulation requirements.

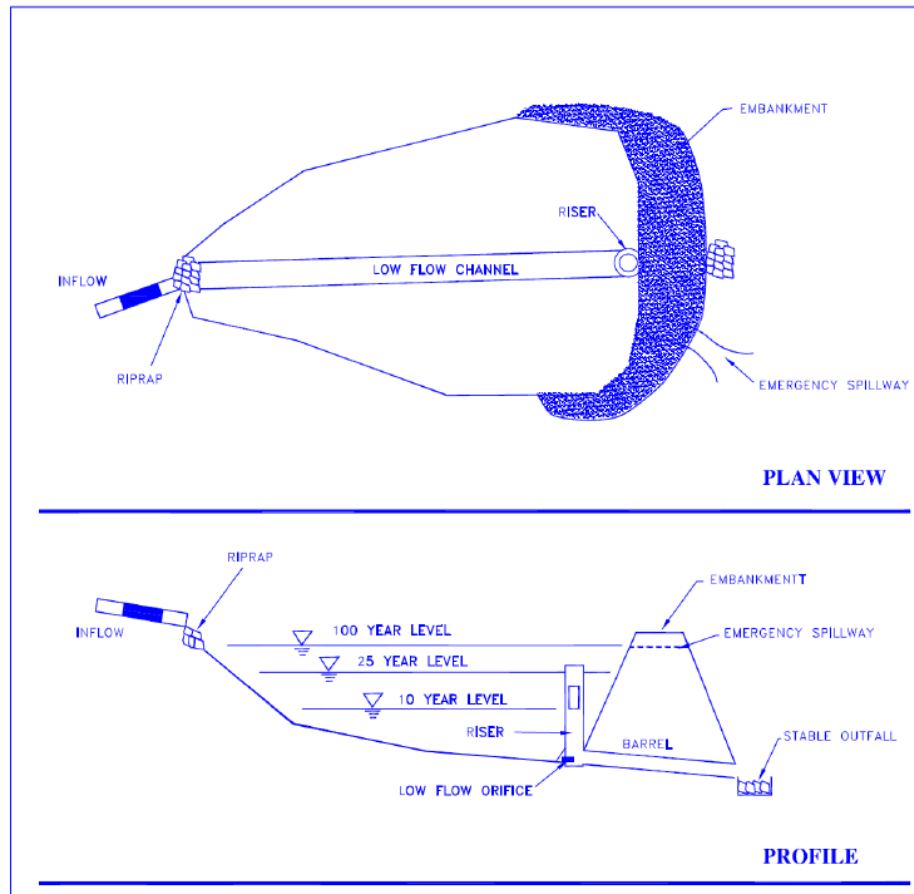

Figure PTP-08- 1 Detention Pond

Source, Center for Watershed Protection

Maintenance A site-specific maintenance plan describing maintenance responsibilities must be developed. that addresses the following items:

- Maintenance access for appropriate equipment, vehicles, and personnel
- Vegetation maintenance schedule that includes mowing multiple times per year
- Inspection checklist
- Maintenance agreement between the facility owner and the City with these items:
 - Sediment removal from the forebay and/or pond when sediment depth is $\frac{1}{2}$ of the total depth to the outlet, or is greater than 1.5 feet (whichever is less)
 - Clean and/or repair outlet devices if drawdown times exceed 48 hours
 - Trash and debris should be removed as necessary
- Grass cover filters should be mowed as needed (maximum grass height of 12 inches)
- Properly dispose of any material generated during maintenance activities.



Maintenance Monthly to Quarterly or After Major Storms (>1")

Check that the maintenance access is free and clear.

- Inspect low flow orifices and all pipes for clogging.
- Check the pond area for debris, bare soil areas and undesirable vegetation.
 - The minimum mowing requirements will be a spring mowing and a fall mowing.
 - Remove debris.
 - Repair undercut, eroded and bare soil areas.
- Look for damaged safety measures or other dangerous items.

Semi-Annual to Annual

- Ensure that the pond's mechanical components (if any) are functional. Repair broken mechanical components if needed.

1-3 Years

- Inspect riser, barrel and embankment for damage. Make any needed repairs.
- Inspect all pipes.
- Monitor sediment deposition in the pond and in the forebay. Remove sediment from the forebay and the pond when needed.

5-25 Years

- Use remote television inspection of the reverse slope pipes, underdrains or other hard-to-access piping. If needed, replace or repair pipes.

Embankment

The pond embankment and/or riser will require inspection by a qualified professional (e.g., structural engineer, geotechnical engineer, etc.) who has experience in the construction, inspection and repair of these features.



**Inspection
Checklist**

All appropriate items should be checked on the inspection checklist. If an applicable item does not meet the condition on the checklist, maintenance and/or repair should be planned.

Monthly

- Maintenance access is free and clear
- Low flow orifice(s) and pipes are free from clogging.
- Pond areas are free of debris.
- Pond area is stabilized with no evidence of erosion.
- Pond areas do not include any undesirable vegetation (i.e., woody vegetation near the embankment, etc.).
- Pond vegetation is mown with grass height no greater than 12 inches.
- There are no damaged safety measures or other dangerous items at the pond.

Semi-Annual to Annual

- The pond's mechanical components (if any) are functional.

1-3 Years

- The riser, barrel and embankment were inspected for damage and do not require repairs.
- All pipes were inspected and do not require repairs or replacement.
- The sediment deposition in the pond and in the forebay was checked, and, if needed, sediment was removed from these areas.

5-25 Years

- Use remote television inspection of the reverse slope pipes, underdrains or other hard-to-access piping. If needed, replace or repair pipes.



Design Criteria

Location and Layout

- As dry detention and dry ED ponds provide limited water quality benefits, they are to be located downstream of other structural stormwater controls providing treatment of the water quality volume (WQ_v) to meet the 80% TSS reduction goal.
- The maximum contributing drainage area to be served by a single dry detention or dry ED pond is 75 acres.
- A minimum separation distance between the pond and the groundwater table and/or an impervious liner may be required for ponds where source water protection is required or for contributing drainage areas designated with “hot spot” landuses.

General Design

- Dry detention ponds are sized to temporarily store the volume of runoff required to provide Q_{p25} protection (i.e., reduce the post-development peak flow of the 25-year storm event to the pre-development rate), and control the 100-year storm (Q_{p100}) if required. The dry detention pond should be sized to release the WQ_v over 24 to 36 hours.

Dry ED ponds are sized to provide extended detention of the water quality volume over 24 hours and can also provide additional storage volume for normal detention (peak flow reduction). Routing calculations must be used to demonstrate that the storage volume is adequate for peak flow attenuation (see Appendix B).

- The dry pond or ED pond must be installed in series with other water quality BMPs to achieve the 80% TSS reduction goal.
- The maximum depth of the pond should not exceed 10 feet.
- Areas above the normal high water elevations of the detention facility should be sloped toward the pond to allow drainage and to prevent standing water. Careful finish grading is required to avoid creation of upland surface depressions that may retain runoff. The bottom area of storage facilities should be graded toward the outlet to prevent standing water conditions. A low flow or pilot channel across the facility bottom from the inlet to the outlet (often constructed with concrete) is recommended to convey low flows and prevent standing water conditions.
- For karst areas, it is recommended that ponds use an impermeable liner and include a minimum three foot separation from the high water table.
- A landscaping plan must address how the pond and the surrounding areas will be stabilized and how vegetation will be established. This plan should include maintenance actions and schedules for the vegetation.
- Pre-treatment measures such as other water quality BMPs and/or forebay(s) are desirable. For areas receiving drainage from potential “hot spot” landuse areas, the pre-treatment measures may need an impermeable liner and/or other separation to keep stormwater separated from groundwater.



Design Criteria

- Direct vehicle/equipment access should be required for forebays to allow for sediment removal and maintenance.
- The bottom of the forebay may be hardened using concrete, asphalt or grouted riprap to make sediment removal easier.

Inlet and Outlet Structures

- Inflow channels are to be stabilized with flared riprap aprons, or the equivalent.
- Pond outlets must be designed to prevent discharge of floating debris.
- Burying all pipes below the frost line can prevent frost heave and pipe freezing.
- A riser or an alternative method may be used for the pond's principal spillway. This riser must include a low flow orifice to allow the pond to fully dewater for a dry pond.
- The outflow riser should be located so that short-circuiting between inflow points and riser does not occur.
- Riprap, plunge pools or pads, or other energy dissipators are to be placed at the end of the outlet to prevent scouring and erosion.

Embankment

- Vegetated embankments shall be less than 20 feet in height and shall have side slopes no steeper than 2:1 (horizontal to vertical) although 3:1 is preferred. Riprap-protected embankments shall be no steeper than 2:1. Geotechnical slope stability analysis is recommended for embankments greater than 10 feet in height and is mandatory for embankment slopes steeper than those given above. All embankments must be designed to State of Kentucky guidelines for dam safety.
- Seepage control or anti-seep collars should be provided for all outlet pipes.
- A minimum of 1 foot of freeboard above the elevation corresponding with the Q_{p100} must be provided for earthen embankments. For dug ponds, the freeboard must be provided and identified in the area of inundation.

Maintenance and Safety

- Adequate maintenance access must be provided for all dry detention and dry ED ponds. One approach for this is to incorporate an access bench (a shallow slope area adjacent to the pond) that will be used for equipment access.
- The forebay of the pond should include a fixed vertical sediment depth marker securely installed in the forebay. This marker will be used as an indicator for when sediment removal is needed in the forebay. Sediment removal should occur for forebay areas when 50% of the total forebay storage capacity is filled with sediment.
- The riser configuration should be planned for future maintenance, lessening the clogging potential, planning access for inspections and maintenance, and safety from improper access by children and/or vandals.



Design Criteria

- Public safety must be considered in every aspect of the pond design.
- Dam safety regulations must be strictly followed in pond design and maintenance to ensure that downstream property and structures are adequately protected.
- OSHA safety procedures must be followed for maintenance activities in enclosed areas, such as outlet structures.

Design Components

Pre-Treatment

- A sediment forebay sized to 0.1 inches per impervious acre of contributing drainage should be provided for dry detention and dry ED ponds that are in a treatment train with off-line water quality treatment structural controls. This forebay may be a small pool separated from the pond area by barriers such as earthen berms, concrete weirs or gabion baskets.

Inlet and Outlet Structures

- Where the outlet structure is connected to an improved sinkhole, zero drawdown through the sinkhole must be assumed.
- For a dry ED pond, a low flow orifice capable of releasing the water quality volume over 24 hours must be provided. The water quality protection orifice should have a minimum diameter of 3 inches and should be adequately protected from clogging by an acceptable external trash rack. The orifice diameter may be reduced to 1 inch if internal orifice protection is used (e.g., an over perforated vertical stand pipe with 0.5-inch orifices or slots that are protected by wire cloth and a stone filtering jacket). Adjustable gate valves can also be used to achieve this equivalent diameter.
- For a dry detention pond, the outlet structure shall be sized according to the detention requirements found in Warren County Government's Subdivision Regulations, Appendix B, and can consist of a weir, orifice, outlet pipe, combination outlet, or other acceptable control structure. Small outlets that will be subject to clogging or are difficult to maintain are not acceptable.
- An emergency spillway is to be included in the stormwater pond design to safely pass the extreme flood flow. The spillway prevents pond water levels from overtopping the embankment and causing structural damage. The emergency spillway must be designed to State of Kentucky guidelines for dam safety and must be located so that downstream structures will not be impacted by spillway discharges.
- A riser or an alternative method may be used for the pond's principal spillway. This riser must include a low flow orifice to allow the pond to fully dewater for a dry pond.
 - For perforated risers, the minimum opening diameter should be ½ inch and the minimum pipe diameter is 8 inches.
 - The low flow orifice for the riser must be adequately protected from clogging. This protection may be an acceptable external trash rack (recommended minimum orifice diameter of 3 inches) or a smaller orifice diameter may be used along with internal orifice protection (recommended minimum diameter of 1 inch).
 - One example alternative method would be to use a broad crested, rectangular, V-notch or proportional weir, protected by a half-round CMP.



Design Components

- The pond must include an emergency spillway to pass storm events in excess of the pond's hydraulic design. The emergency spillway must be stabilized to prevent erosion, must comply with state dam safety requirements and must be located so that downstream structures will not be impacted by spillway discharges. If the emergency spillway crosses the maintenance access for the pond, materials meeting the appropriate load requirements must be selected.
- Riprap, plunge pools or pads, or other energy dissipators are to be placed at the end of the outlet to prevent scouring and erosion. If the pond discharges to a channel with dry weather flow, care should be taken to minimize tree clearing along the downstream channel, and to reestablish a forested riparian zone in the shortest possible distance.
- For outlets, it is recommended that a stilling pond or outlet protection be used to reduce outflow velocities to non-erosive velocities and shear stresses.

Pond

As dry detention and dry ED ponds provide limited water quality benefits (60% TSS reduction), they are to be located downstream of other structural stormwater controls providing treatment of the water quality volume (WQ_v) to provide the full 80% TSS reduction.

- Adequate maintenance access must be provided for all dry detention and dry ED ponds. One approach for this is to incorporate an access bench (a shallow slope area adjacent to the pond) that will be used for equipment access.
 - The recommended access bench width is 10 feet (minimum 8 feet).
 - The maximum access bench cross-slope should be 0.06:1 (V:H) or 6%.
 - Use a maximum bench slope of 0.15:1 (V:H).
 - The bench should be appropriately stabilized for vehicle and equipment access.
 - This bench may also consider extending to other areas such as forebays, inlet and outlet, and should also consider the need for vehicle turn around space.
 - Access benches are not needed for ponds with side slopes that are 1:4 (V:H) or flatter.
 - The recommended maintenance access will connect with a maintenance right-of-way or easement (if needed) that will extend from the pond to a public or a private road.
- The maximum contributing drainage area to be served by a single dry detention or dry ED pond is 75 acres.
- The minimum length to width ratio for the pond is 1.5:1.
- It is recommended that the pond's footprint cover approximately 1-3% of the contributing drainage area.



Design Components

- A minimum separation distance between the pond and the groundwater table and/or an impervious liner may be required for ponds where source water protection is required or for contributing drainage areas designated as “hot spots”.
- Side slopes should not exceed 1V:3H.
- The slopes immediately adjacent to the pond should be less than 25% but greater than 0.5-1% to maintain positive drainage toward the pond.
- For karst areas, it is recommended that ponds use an impermeable liner and include a minimum three foot separation from the barotic rock layer. Liner options include a layer of 6-12 inches of clay soil including bentonite (minimum 15% passing the #200 sieve and a maximum permeability of $1X 10^{-5}$ cm/sec), a 30 mL polyliner or another approved engineering design.
- A landscaping plan must address how the pond and the surrounding areas will be stabilized and how vegetation will be established. This plan should include maintenance actions and schedules for the vegetation.
- Inspections during construction are needed to confirm that the pond is being built according to the approved design standards and specifications. A detailed construction inspection checklist should be developed that will include sign-offs by qualified individuals at critical construction stages to ensure that the contractor’s interpretation of the plan is acceptable to the project’s professional designer. As-built inspection documentation is required.

Embankment

- Vegetated embankments shall be less than 20 feet in height and shall have side slopes no steeper than 2:1 (horizontal to vertical) although 3:1 is preferred. Riprap-protected embankments shall be no steeper than 2:1. Geotechnical slope stability analysis is recommended for embankments greater than 10 feet in height and is mandatory for embankment slopes steeper than those given above. All embankments must be designed to State of Kentucky guidelines for dam safety.
- Seepage control or anti-seep collars should be provided for all outlet pipes.
- A minimum of 1 foot of freeboard must be provided, measured from the top of the water surface elevation for the extreme flood, to the lowest point of the dam embankment not counting the emergency spillway.
- For earthen embankments, suitable soils must be used to construct the embankment.
- Woody vegetation should not be planted or allowed to grow within 15 feet of the embankment toe and within 25 feet of the inlet and outlet structures.



Design Procedure

Step 1 – Make a preliminary judgment as to whether site conditions are appropriate for the use of a dry pond or dry ED pond, and identify the function of the pond in the overall treatment system. This includes performing an initial suitability screening for the site.

- Consider basic issues for initial suitability screening, including:
 - Site drainage area
 - Site topography and slopes
 - Soil characteristics
 - Depth to water table and bedrock
 - Presence of active karst features and/or wetlands
 - Post-development landuse (Is it a potential “hot spot” landuse?)
- Determine how the dry pond or dry ED pond will fit into the overall stormwater treatment system.
 - Keep in mind that other water quality BMPs are needed upslope of the pond for impervious area drainage, and that the pond cannot be a primary water quality BMP.
 - Decide where on the site the pond is most likely to be located.
- Determine how the dry pond or dry ED pond will fit into the overall stormwater treatment system.

Step 2 – Confirm design criteria, site constraints and applicability.

- Determine the design criteria that will be used.
 - Local construction and stormwater requirements
 - State stream construction permitting (if in a floodplain area)
 - State dam safety guidance (for ponds with embankments)
 - Any other criteria or restrictions that apply
- Determine any constraints the site will place on the pond such as:
 - Limited amount of space and surface area available for treatment
 - High water table
 - Active karst areas
- Determine the TSS reduction provided, using the equations below for weighted TSS reduction, $TSS_{weighted}$, and TSS treatment train, TSS_{train} . The minimum TSS reduction required for the site is 80% and can be weighted for the site.

$$\% TSS_{weighted} = \frac{\sum_n^1 (TSS_n A_n)}{\sum_n^1 (A_1 + A_2 + \dots + A_n)}$$

Where runoff is treated by two or more BMPs in series, the TSS reduction provided is calculated with the following equation for a treatment train:



Design Procedure

$$TSS_{\text{train}} = A + B - \frac{(A \times B)}{100}$$

Where A is the TSS reduction provided by the first BMP and B is the TSS reduction provided by the next BMP.

Step 3 – Confirm site suitability, including field verification of site suitability.

- The field verification should be conducted by a qualified geotechnical professional.
- The recommended minimum is one soil boring per acre with a minimum of three soil borings or pits dug at the same location as the proposed pond. The borings or pits will be used to verify soil types and to determine the depth to groundwater and bedrock.
- The recommended minimum depth of the soil borings or pits is five feet below the bottom elevation of the proposed pond.

Step 4 – Compute runoff control volumes and peak flows. Refer to Chapter 2 and Appendix B for more information on these values. Note that this design is only for water quality treatment, not *quantity* control. Therefore, only TSS reduction and WQ_v design is included.

- Calculate the Water Quality Volume (WQ_v).

$$WQ_v = [P R_v(A)]/12$$

Where:

P = is the average rainfall, (inches)

$R_v = 0.05 + 0.009(I)$, where I is the percent impervious cover

A = the area of imperviousness, (acres)

- Calculate the peak flow for the Water Quality Volume (Q_{wq}).

$$Q_{wq} = C \times I_{wq} \times A$$

Where:

Q_{wq} = the water quality volume peak flow, (cfs)

C = the runoff coefficient

I_{wq} = the rainfall intensity, (in/hr)

A = the area of imperviousness, (acres)

- Calculate the volume for the Peak Flow attenuation. See appendix B for more information on detention requirements.

If the pond will be used as the only BMP for rate control for larger storms, the pond should be designed to treat the entirety of each of these runoff control volumes. If other BMPs will be used to control portions of these runoff control volumes, the portion handled by other BMPs may be subtracted from the appropriate volumes to determine the volumes to be controlled in the pond.



Design Procedure

Note: Steps 5 – 12 may be iterative to achieve a pond design that meets the required performance and the site constraints.

Step 5 – Determine the pond location and preliminary geometry.

- Use the following steps to develop the preliminary grading plan for the pond.
 - Locate the pond at the site's lowest elevation area that is not in a jurisdictional wetland or active karst area. Provide space around the pond for maintenance access (minimum width of 8 feet, recommended minimum width of 10 feet).
 - Provide storage based on the water quality volume (WQ_v), volume for the Q_{p25} and Q_{p100} .
 - Considering the desired pond footprint during the WQ_v , allocate storage volume above the riser bottom orifice for WQ_v . Flow attenuation must be provided for the Q_{p25} and Q_{p100} . While developing the grading plan, consider the desired (or required) length to width ratio and side slopes based on the Design Criteria and Design Components information.
 - Once the preliminary grading plan has been developed, determine the associated stage-storage relationship for water surface elevations through the maximum expected levels.
- Use the average end area method (or other equivalent method) to calculate the approximate storage at a given stage (elevation). The area within each of the closed contour lines on the pond's grading plan is measured. The average area is calculated between two adjacent contours. The average areas are then multiplied by the elevation difference to calculate the approximate volume between the two contours.

$$V_{1-2} = \frac{A_1 + A_2}{2} \times (E_2 - E_1)$$

Where:

V_{1-2} = the volume between contour 1 and contour 2 (acre-feet)

A_1 and A_2 = the areas within closed contours 1 and 2, respectively (acres)

E_1 and E_2 = the elevations of contours 1 and 2, respectively (feet)

The cumulative pond volume above the bottom of the pond can be calculated by adding the incremental volumes. The stages (elevations) and the corresponding storages can be used to develop a stage-storage-discharge table as the outlet structures are designed. This is an iterative process that may require revising the preliminary grading plan and recalculating the stage-storage relationship until all of the items in Design Criteria and Design Components are satisfied.

STEP 6 – Determine the pre-treatment volume for the sediment forebay.

- Where there are no adequate upstream treatment BMPs, a sediment forebay or a similarly performing treatment system is recommended at each inlet to the pond that conveys 10% or more of the total design inflow.



Design Procedure

- The recommended forebay volume is 10% of the WQ_v with a depth of 4-6 feet. More shallow depths increase the potential for sediment re-suspension in the forebay.
- Both the storage volume of the forebay and the storage volumes for other water quality BMPs upstream in the treatment train count toward the required water quality volume, and may be subtracted from the total water quality volume required.

STEP 7 – Size and design the outlet structures.

- The pond must include the following outlet stages in the pond design. It is possible to design one device to meet all required stages.
- The assumed water quality volume (low flow) outlet is an orifice at the bottom of the riser designed to release WQ_v with an average detention time of 24 hours. After designing the low flow orifice, the design should be checked to verify that the release rate is no greater than 5.66 cfs/acre of pond surface area.
- The pond must also be designed to meet the requirements of Warren County Government's Subdivision Regulations, Appendix B.
- The following outlet equations are based on assumptions about the outlet structure type that will be used to control flows at various stages. If a different structure type is selected, the designer must use specific equations for structure type to determine the stage-discharge relationships. However, the general design approach will remain the same even if a different outlet structure type is used for the pond calculations.
- The average release rate of WQ_v (Q_{WQ_avg}) is calculated using the following equation: Hydrologic software can be used for determining the release rate and stage-storage table.

$$Q_{WQ_avg} = \frac{WQ_v}{t_{WQ}}$$

Where:

Q_{WQ_avg} = average release rate of WQ_v (cfs)

t_{WQ} = the intended WQ_v detention time (seconds)

WQ_v = water quality volume (cubic feet)

- From the stage-storage table, find the elevation associated with WQ_v . Calculate the approximate average head (in feet) on the water quality outlet (h_{wq_avg}) using the following equation:

$$h_{wq_avg} = \frac{E_{WQ} - E_{PermPool}}{2}$$

Where:

h_{wq_avg} = average head on the water quality outlet (feet)

E_{WQ} = the WQ_v pool elevation (feet)

$E_{PermPool}$ = the permanent pool elevation (feet) at the invert of the water quality orifice. For a dry pond, this elevation is at the bottom of the pond.



Design Procedure

Using the determined opening and spillway information, incorporate the outlet structures into the pond design. Keep in mind that the spillway design must also consider using measures such as removable trash racks to prevent the discharge of floating debris.

STEP 8 – Design the spillways and embankments.

- All spillway and embankment design must meet any applicable state and/or local criteria.
- The emergency spillway must be stabilized.
- The embankments must be overfilled by at least 5% to allow for settling.
- The minimum embankment width is 6 feet. A wider embankment width may be preferred for maintenance access.
- All embankments must be adequately stabilized with appropriate non-woody vegetation or other measures.
- The embankment and spillway side slopes should be no steeper than 1:3 (V:H).
- Using the determined opening and spillway information, incorporate the outlet structures into the pond design. Keep in mind that the spillway design must also consider using measures such as removable trash racks to prevent the discharge of floating debris.

STEP 9 – Design the inlets.

- If inflow inlet pipes are used, it is recommended that the pipes be buried below the frost line.
- Inlet design should consider preventing or reducing scour by including riprap or flow diffusion devices such as plunge pools or berms.

STEP 10 – Design the sediment forebay.

- The sediment forebay size was determined in Step 6.
- The bottom of the forebay may be hardened using concrete, asphalt or grouted riprap to make sediment removal easier.
- The forebay outlets should include non-erosive conditions as flows move from the forebay to the pond.
- The forebay of the pond should include a fixed vertical sediment depth marker securely installed in the forebay. This marker will be used as an indicator for when sediment removal is needed in the forebay. Sediment removal should occur for forebay areas when 50% of the total forebay storage capacity is filled with sediment.

STEP 11 – Design the maintenance access and safety features.

- Maintenance access and safety features should meet the requirements included in the Design Criteria and Design Component sections.
- Any additional safety features or signage should be added as appropriate.



Design Procedure

- Calculate the required orifice cross-sectional area indirectly by using the orifice equation.

$$Q_{WQ_avg} = C A_{WQ} \sqrt{2gh_{wq_avg}}$$

Where:

C = the orifice coefficient (0.6 is typically used, but not apply for all cases)

A_{WQ} = the orifice area (square feet)

g = gravitational acceleration (32.2 feet/s²)

- Calculate the orifice diameter using the following equation:

$$d_{WQ} = 2 \sqrt{\frac{A_{WQ}}{\pi}}$$

Where:

d_{WQ} = the orifice diameter (feet)

- The rate of discharge for the orifice for any head value at the water quality orifice (h_{WQ}) can be calculated using:

$$Q_{WQ} = C A_{WQ} \sqrt{2gh_{WQ}}$$

Where:

Q_{WQ} = the orifice discharge rate at head h_{WQ} (cfs)

h_{WQ} = the head value above the water quality orifice (feet)

- Calculate the control for the 25-year, 24-hour runoff peak flow (Q_{P25}). The calculation procedures will be similar to those used for the low flow orifice except that any higher outflow openings (i.e., perforated riser openings, weir, orifices, etc.) would be included as well. The combined outflow from all openings must be such that the post-development Q_{P25} does not exceed the pre-development Q_{P25} .
- The combined outflow from the low flow orifice and any higher outflow openings is calculated by adding together the discharges from each structures associated with a given head value and a specified pond water surface elevation.
- Calculate the required control for the 100-year storm peak flow (Q_{P100}). If required, the post-development Q_{P100} must be no greater than the pre-development Q_{P100} . At minimum, Q_{P100} must be able to be safely passed through the pond with 1-2 feet of freeboard below the top of the embankment. Check with local officials and/or state dam safety personnel to determine whether Q_{P100} may be passed using only a principal spillway, or if a combination of a principal spillway and emergency spillway will be required. If an emergency spillway is required, the spillway type is often a broad-crested weir or similar structure that is not easily obstructed. The combined outflow through all spillway openings is calculated by adding together the discharges for each opening associated with a given head value and a specified water surface elevation.



Design Procedure

- Dam safety regulations must be strictly followed in pond design and maintenance to ensure that downstream property and structures are adequately protected.
- OSHA safety procedures must be followed for maintenance activities in enclosed areas, such as outlet structures.

STEP 12 – Check the expected pond performance against regulatory requirements.

- The pond design should be re-checked to confirm that the pond meets the flow control requirements.
- The average detention time for WQ_v is 12 hours. The release rate for WQ_v should not exceed 5.66 cfs per acre of pond area.
- Post-development Q_{P25} is no more than the pre-development Q_{P25} .
- If required, post-development Q_{p100} is no greater than the pre-development Q_{p100} .
- If required, the post-development Q_{p100} must be able to be safely passed through the pond while maintaining 1-2 feet of freeboard below the top of the embankment.
- The % TSS removal for the treatment train (upstream water quality BMPs and pond) must be 80% or greater.

STEP 13 – Prepare the vegetation and landscaping plan.

The vegetation and landscaping plan should include soil preparation information, vegetation type and vegetation maintenance. The plan should include information about where woody vegetation is not appropriate (i.e., embankment areas, near spillways where access may be affected, etc.). The plan should also include information about reapplying stabilization measures to areas where vegetation growth is sparse.

STEP 14 – Prepare the operation and maintenance plan.

The operation and maintenance plan should include maintenance information and inspection checklists similar to those discussed in this practice's fact sheet.



Example Design



Proposed development of an undeveloped site into an office building and associated parking.

| Base Data | Hydrologic Data | |
|---|--------------------------------------|------------|
| Total drainage area = 5 ac | Pre | Post |
| Site Area = 3.54 ac | CN 71 | 89 |
| Soils Type "C" | WQ_v Depth = 1.1 in | |
| Pre-Development | Precipitation | |
| Impervious Area = 0 ac; or I = 0% | l _{wq} | 2.45 in/hr |
| Meadow (CN = 71) | 2yr, 24hr | 3.54 in |
| Post-Development | 25yr, 24hr | 5.88 in |
| Impervious Area = 1.72 ac; or I = 1.72/3.54 = 49% | 100yr, 24hr | 7.43 in |
| Open Space, Fair (CN = 79) | | |
| Paved parking lots, roofs, driveways, etc. (CN =98) | | |

This example focuses on the design of dry extended detention (ED) pond to meet the water quantity control requirements and to also be a part of the treatment train for the site's water quality treatment requirements. This example design focuses on water quality volume (WQ_v) control only. However, similar design procedures would be used to design for the other water quantity control requirements. In general, the primary function of the dry ED pond is to provide large storm attenuation rather than to provide water quality treatment.



Example Design

Problem: Design a post-construction stormwater water quantity dry extended detention (ED) pond for this site. The dry ED pond will be constructed to meet the required detention standards and will provide 60% TSS reduction for the site. Sand filters are to be installed upstream of the dry ED pond so that the % TSS removed by the treatment train is over 80%. The total drainage area to the pond is 5 acres. Try designing the dry ED pond for this site.

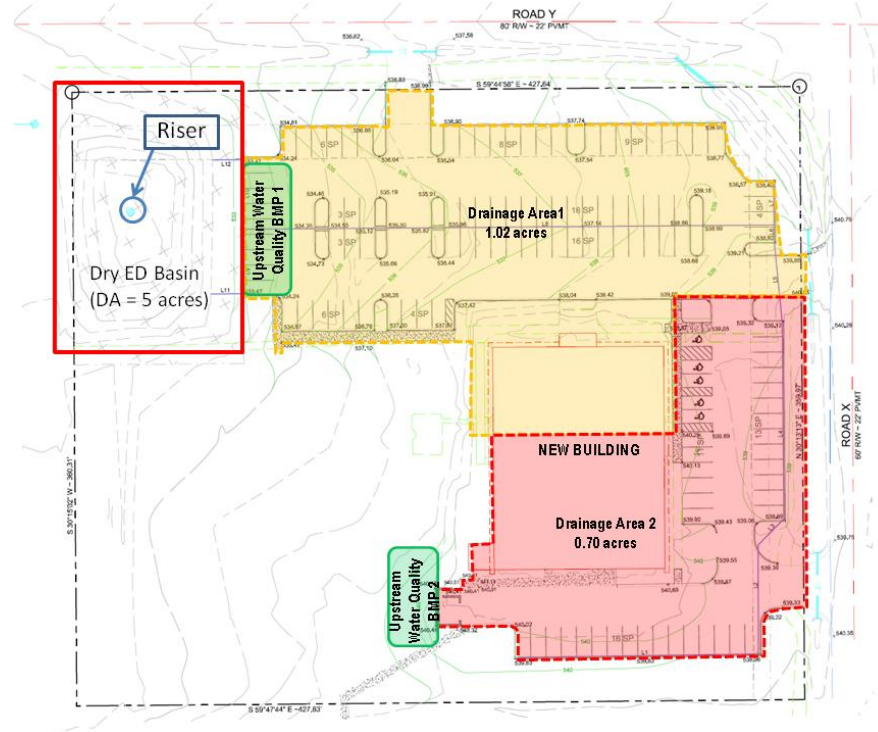

Step 1 – Make a preliminary judgment as to whether site conditions are appropriate for the use of a dry pond or dry ED pond, and identify the function of the pond in the overall treatment system. This includes performing an initial suitability screening for the site.

- Consider basic issues for initial suitability screening, including:
 - The total drainage area to the pond is 5 acres.
 - The site's topography and slopes show that the northwest corner of the site is the preferred pond location.
 - The site has type "C" soils
 - The depth to the water table and bedrock show that the northwest corner of the site is a suitable location for a dry ED pond.
 - There are active karst areas on the site.
 - The proposed development is a commercial office building with associated parking.



Example Design

- Determine how the dry pond or dry ED pond will fit into the overall stormwater treatment system.
 - The proposed dry ED pond will be a downstream component of a treatment train for TSS removal. Two separate sand filters will be designed and installed upgradient (identified as Upstream Water Quality BMP 1 and 2).
 - The northwest corner of the site is the best candidate location for the dry ED pond.
 - The treated WQ_v from the two sand filters will be conveyed through pipes or other stabilized conveyances into the dry ED pond. All pervious site areas as well as all contributing pervious off-site drainage areas will be well-stabilized with vegetative cover. Therefore, the dry ED pond design will not require a separate sediment forebay at the dry ED pond. If a forebay were to be used for the design, one could be located at the south end of the pond.
- Step 2** – Confirm design criteria, site constraints and applicability.
 - The following minimum criteria will be used in the design.
 - The dry ED pond must meet the following criteria:
 - The WQ_v must have an average detention time of 12 hours.
 - The post-development 25-year peak flow (Q_{P25}) discharged from the pond must be no greater than the pre-development 25-year peak flows (Q_{P25}).
 - For this location, the City is not requiring that the 100-year peak flow to be controlled by the dry ED pond, but is requiring the pond to be able to safely pass the 100-year peak flow through the principal spillway.
 - The dry ED pond is a part of a water quality treatment train that will meet the City's requirement for % TSS removal.
 - The site is not within a floodplain area.
 - The pond is bounded on two sides by existing streets, and will not require an embankment (i.e., the pond is excavated). Therefore, no state dam safety approvals are needed.
 - The outlet structure will be an improved sinkhole. Improved sinkholes must be inventoried, with specific information provided to US EPS. The inventory form can be found at www.bgky.org under the Stormwater Section page.
 - The following items are the site constraints related to the pond:
 - The proposed pond location is bounded on two sides (north and west) by existing streets. The design for high flow conditions must consider street flooding potential.
 - The proposed pond's principal spillway discharge will not impact roads or buildings downstream (and also off-site).



Example Design

- Determine the TSS reduction provided, using the equations below for weighted TSS reduction, $TSS_{weighted}$, and TSS treatment train, TSS_{train} . The two upstream water quality BMPs are sand filters with 80% TSS removal. The dry ED pond has 60% TSS removal. All runoff from impervious surfaces goes to the sand filters and dry ED pond.

$$\%TSS_{train} = 80 + 60 - \frac{80 * 60}{100} = 92\%$$

Step 3 – Confirm site suitability, including field verification of site suitability.

- The site geotechnical investigation showed that proposed pond location was suitable for installing a dry ED pond and that the sinkhole can be improved to serve as the primary spillway.
- The soil borings indicated that the underlying soils in the vicinity of the proposed dry ED pond had limited infiltration capacity and that the high water elevation allowed a minimum 3-foot separation between the bottom of the pond and the high water elevation.
- No impermeable layers/lenses or bedrock was encountered during the geotechnical field evaluation of the site.

Step 4 – Compute runoff control volumes and peak flows. Refer to Appendix B for more information on peak flow attenuation for Q_{p25} and Q_{p100} .

- Calculate the Water Quality Volume (WQ_v).

Total Site WQ_v :

$$WQ_v = [(P R_v)(A)]/12$$

Where:

$$P = 1.1 \text{ inches}$$

$$R_v = 0.05 + 0.009(I)$$

$$I = 49$$

$$R_v = 0.05 + 0.009(49) = 0.491$$

$$A = 1.72 \text{ acres}$$

$$WQ_v = (1.1 \text{ in} \times 0.491 \times 1.72 \text{ ac})/12 = 0.077 \text{ acre-ft} = 3373 \text{ ft}^3$$



Example Design

- Calculate the peak flow for the Water Quality Volume (Q_{wq}). The equation below is based on the Rational Method. The Rational Method equation is an empirical equation, and the input units do not match up with the output units.

$$Q_{wq} = C \times I_{wQ} \times A$$

Where:

Q_{wq} = the water quality volume peak flow, (cfs)

C = the runoff coefficient (0.90 for impervious areas)

I_{wQ} = 2.45 in/hr

A = 1.72 acres

$$Q_{wq} = 0.90 \times 2.45 \times 1.72 = 3.79 \text{ cfs}$$

- Calculate the Q_{p25} and Q_{p100} . The NRCS hydrograph method is recommended for these calculations.

For the Example Design, the focus will be on sizing the pond based on WQ_v . Therefore, higher flow event calculations are not included.

Note: Steps 5 – 12 may be iterative to achieve a pond design that meets the required performance and the site constraints.

First Iteration

Step 5 – Determine the pond location and preliminary geometry.

- These items were used to develop the preliminary grading plan for the pond.
 - The pond's lowest elevation is not in a jurisdictional wetland. The maintenance access for the pond will be on the eastern side of the pond near the parking area. Additionally, the pond side slopes here are approximately 1.4% or 7:1 (H:V)
 - The pond bottom elevation is at 524.80 feet. This elevation will also be the invert for the low flow orifice control WQ_v .
 - The pond is assumed to have sufficient storage for all required controlled discharges.
 - The outlet riser is centrally located in the pond, and cannot be moved farther away from the pond inlets due to the existing roadways nearby. The central riser location helps maximize the available length to width ratio.



Example Design

STEP 6 – Determine the pre-treatment volume for the sediment forebay.

- This design example does not include a sediment forebay as discussed earlier.
- If a forebay were used, it would be designed to hold 10% of WQ_v , or about 338 ft³.

STEP 7 – Size and design the outlet structures.

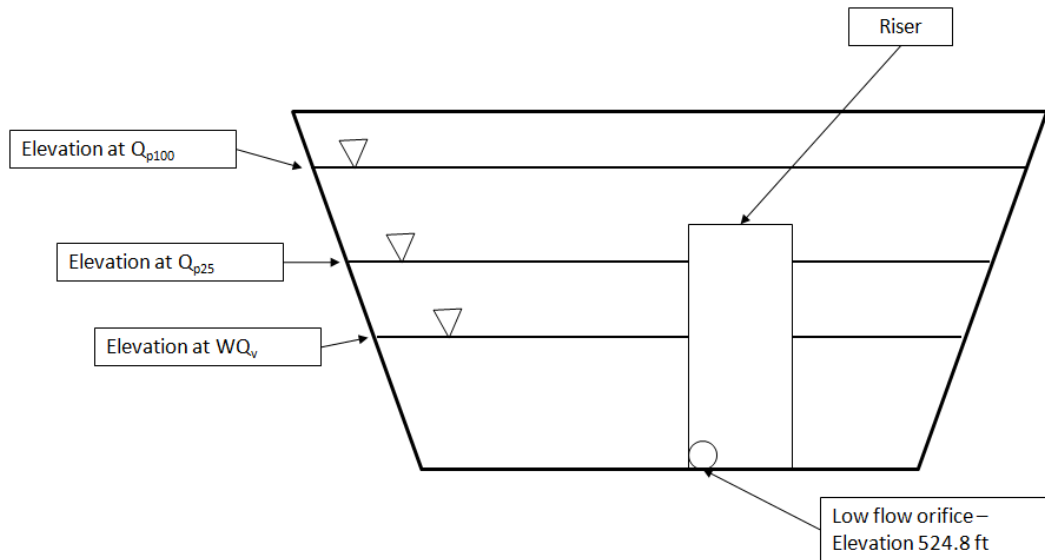

- The assumed outlet structure will be an improved sinkhole throat with a principal spillway riser that has a low flow orifice for controlling WQ_v , perforations in the riser for controlling Q_{P25} , and a top riser opening for passing Q_{p100} . The example design will not include outlet calculations for the higher flow events.
- The assumed water quality volume (low flow) outlet is an orifice at the bottom of the riser designed to release WQ_v with an average detention time of 24 hours.
- The average release rate of the WQ_v (Q_{WQ_avg}) is calculated using the following equation:

$$Q_{WQ_avg} = \frac{WQ_v}{t_{WQ}}$$

Where:

t_{WQ} = the intended WQ_v detention time = 24 hours = 86,400 seconds

WQ_v = 3373 ft³

Q_{WQ_avg} = average release rate of WQ_v (cfs)

$$Q_{WQ_avg} = \frac{3373 \text{ ft}^3}{86400 \text{ seconds}} = 0.039 \text{ cfs}$$



Example Design

- The proposed stage-storage relationships for the pond are summarized in the table and chart shown below:

| Elevation E (ft) | Area A (square feet) | Average Area between Elevations | Average Area (ft ²) | Depth (Elevation Difference) | Incremental Volume (ft ³) | Cumulative Volume (ft ³) |
|------------------|----------------------|---------------------------------|---------------------------------|------------------------------|---------------------------------------|--------------------------------------|
| 524.8 | 0 | NA – pond bottom | NA – pond bottom | NA – pond bottom | 0 | 0 |
| 527 | 1266 | 524.8 ft & 527 ft | 633 | 2.2 | 1392.6 | 1392.6 |
| 528 | 3024 | 527 ft & 528 ft | 2145 | 1 | 2145 | 3537.6 |
| 529 | 4709 | 528 ft & 529 ft | 3866.5 | 1 | 3866.5 | 7404.1 |
| 530 | 6744 | 529 ft & 530 ft | 5726.5 | 1 | 5726.5 | 13130.6 |
| 531 | 9169 | 530 ft & 531 ft | 7956.5 | 1 | 7956.5 | 21087.1 |

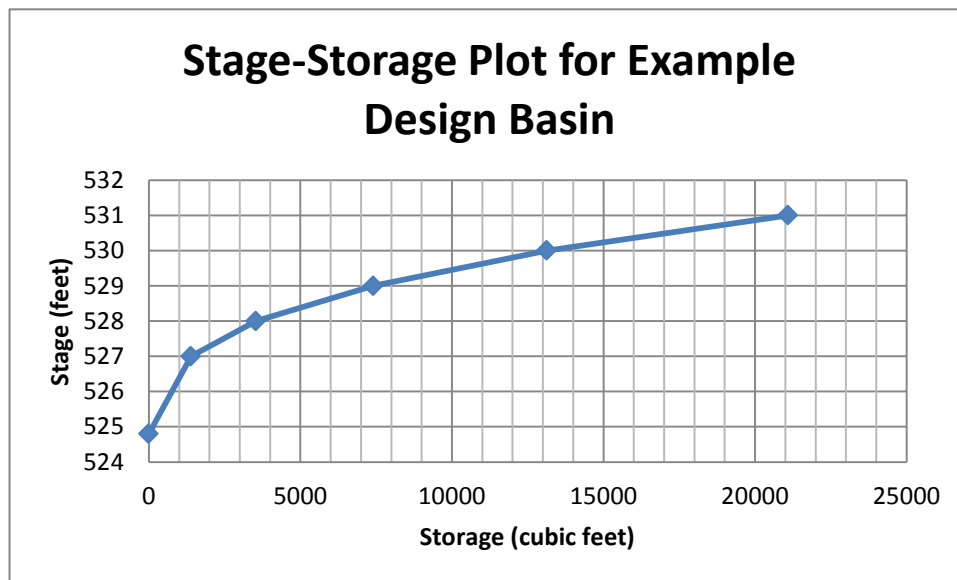

- The proposed pond's storage volume is sufficient to hold the WQ_v , and is assumed to be sufficient for the other required peak flow controls.

STEP 7 – Determine the pre-treatment volume for the sediment forebay.

- This design example does not include a sediment forebay as discussed earlier.
- If a forebay were used, it would be designed to hold 10% of WQ_v , or about 338 ft³.



Example Design

- From the stage-storage table, find the elevation associated with WQ_v . The table indicates that $WQ_v = 3373 \text{ ft}^3$ is between elevations 527 ft and 528 ft. The stage-storage relationship plot may be used to estimate the elevation associated with WQ_v , or the elevation may be obtained by linear interpolation between the table values. The elevation associated with WQ_v is estimated at 527.92 feet.
- Calculate the approximate average head (in feet) on the water quality outlet (h_{wq_avg}) using the following equation:

$$h_{wq_avg} = \frac{E_{WQ} - E_{PermPool}}{2}$$

Where:

$$E_{WQ} = 527.92 \text{ feet}$$

$$E_{PermPool} = \text{bottom elevation of the pond} = 524.80 \text{ feet.}$$

$$h_{wq_avg} = \frac{3.12 \text{ feet}}{2} = 1.56 \text{ feet}$$

- Calculate the required orifice cross-sectional area indirectly by using the orifice equation.

$$Q_{WQ_avg} = CA_{WQ} \sqrt{2gh_{wq_avg}}$$

Where:

$$Q_{WQ} = 0.039 \text{ cfs}$$

C = the orifice coefficient (0.6 is typically used, but not apply for all cases)

A_{WQ} = the orifice area (square feet)

g = gravitational acceleration (32.2 feet/s²)

First, rearrange the orifice equation to solve for A_{WQ} .

$$A_{WQ} = \frac{Q_{wq_avg}}{C\sqrt{2gh_{wq_avg}}}$$

$$A_{WQ} = \frac{0.039 \text{ cfs}}{0.6\sqrt{2\left(32.2\frac{\text{ft}}{\text{s}^2}\right)(1.56 \text{ feet})}} = 0.0065 \text{ feet}^2$$

$$A_{WQ} = 0.0065 \text{ feet}^2$$



Example Design

- Calculate the orifice diameter using the following equation:

$$d_{wQ} = 2 \sqrt{\frac{A_{wQ}}{\pi}}$$

Where:

d_{wQ} = the orifice diameter (feet)

$$d_{wQ} = 2 \sqrt{\frac{0.0065 \text{ feet}^2}{3.14}} = 0.09 \text{ feet}$$

$$d_{wQ} = 0.09 \text{ feet} = 1.10 \text{ inches} \approx 1 \text{ inch}$$

For the Example Design, the minimum allowed orifice diameter (1 inch) will be used. This device will require internal orifice protection.

- The rate of discharge for the orifice for any head value at the water quality orifice (h_{wQ}) can be calculated using:

$$Q_{wQ} = C A_{wQ} \sqrt{2gh_{wQ}}$$

Where:

Q_{wQ} = the orifice discharge rate at head h_{wQ} (cfs)

h_{wQ} = the head value above the water quality orifice (feet)

Using the range of values for h_{wQ} based on the elevations (E) up to E_{wQ} used in the pond's stage-storage relationship, the Q_{wQ} values are calculated for each corresponding value of h_{wQ} .

| Elevation E (ft) | h_{wQ} (feet) | Q_{wQ} (cfs) |
|------------------|-----------------|----------------|
| 524.8 | 0 | 0 |
| 527 | 2.2 | 0.0390 |
| 527.92 | 3.12 | 0.0464 |



Example Design

- The combined outflow from the low flow orifice and any higher outflow openings is calculated by adding together the discharges from each structures associated with a given head value and a specified pond water surface elevation.

The combined outflow would be calculated for all of the outflow openings to check that the pond meets the requirements for controlling the post-development Q_{P25} .

- Calculate the required control for the 100-year storm peak flow (Q_{p100}). If required, the post-development Q_{p100} must be no greater than the pre-development Q_{p100} . At minimum, Q_{p100} must be able to be safely passed through the pond with 1-2 feet of freeboard below the top of the embankment. Check with local officials and/or state dam safety personnel to determine whether Q_{p100} may be passed using only a principal spillway, or if an emergency spillway will be required. If an emergency spillway is required, the spillway type is often a broad-crested weir or similar structure that is not susceptible to obstruction. For calculating the combined outflow through all spillway openings, the combined outflow may be calculated by adding together the discharges for each opening associated with a given head value and a specified water surface elevation.

For this Example Design, the pond's ability to control Q_{p100} will not be calculated. The Example Design pond is an excavated pond that does not include an embankment other than the two existing roadbeds north and west of the site. However, the pond would still need to be checked to determine if the pond could safely pass Q_{p100} while maintaining the required freeboard of 1-2 feet above the elevation associated with the Q_{p100} .

- Using the determined opening and spillway information, incorporate the outlet structures into the pond design. Keep in mind that the spillway design must also consider using measures such as removable trash racks to prevent the discharge of floating debris.

The outlet openings and spillways are then added into the pond design. Other measures such as removable trash racks are also added to the design.

STEP 8 – Design the spillways and embankments.

- The Example Design pond will target passing all required flows through the principal spillway, and will not be required to include an emergency spillway.

STEP 9 – Design the inlets.

- The Example Design pond uses inflow inlet pipes from the upstream water quality BMPs to the pond. These inflow inlet pipes are designed to be buried below the frost line. Additionally, this pond is a dry pond (no permanent pool). This means that the inlet pipes should be sloped to fully drain as the water levels in the pond drop.

STEP 10 – Design the sediment forebay.

- The sediment forebay size was determined in Step 6. For the Example Design pond, a sediment forebay will not be used because (1) the upstream water quality BMPs will reduce the sediment load to the pond and (2) all pervious areas draining to the pond will be well-stabilized to not provide significant sediment load to the dry ED pond.



Example Design

STEP 11 – Design the maintenance access and safety features.

- All maintenance access and safety features are designed in this step. The removable trash racks on the spillway riser will also function to prevent unauthorized access to the riser. The riser's pipe diameter will include bars across the pipe outlet to prevent unauthorized access if the pipe diameter is over 3 feet.

STEP 12 – Check the expected pond performance against regulatory requirements.

- The pond design should be re-checked to confirm that the pond meets the flow control requirements.
- The release rate for WQ_v should not exceed 5.66 cfs per acre of pond surface area. Calculate the flow rate and pond surface area associated with each available elevation and head value up to E_{WQ} . The maximum release rate for WQ_v will then be calculated using the pond surface area at each given elevation and head value, and the actual release rate will be compared with the maximum release rate.

| Elevation E (ft) | h_{WQ} (feet) | Q_{WQ} (cfs) | Pond Surface Area at E (sq ft) | Pond Surface Area at E (acres) | Release rate (based on Q_{WQ} per acre of surface area) (cfs/acre) |
|------------------|-----------------|----------------|--------------------------------|--------------------------------|--|
| 524.8 | 0 | 0.000 | 0 | 0 | 0 |
| 527 | 2.2 | 0.039 | 1266 | 0.0291 | 1.34 |
| 527.92 | 3.12 | 0.046 | 3373 | 0.0774 | 0.60 |

See last column in above table. All values are below the target value of 5.66 cfs per acre.

- The expected average detention time for WQ_v is 24 hours. Calculate the average release rate for the pond (Q_{WQ_avg}). Use WQ_v and Q_{WQ_avg} to calculate the actual average detention time for the pond. The required target detention time for WQ_v is 24 hours.

$$Q_{WQ_avg} = \frac{0+0.039+0.046}{3} = 0.028 \text{ cfs}$$

$$t_{WQ} = \frac{WQ_v}{Q_{WQ_avg}} = \frac{3373 \text{ ft}^3}{0.028 \text{ cfs}} = 118574 \text{ seconds} = 32.9 \text{ hours}$$

The actual value of t_{WQ} is greater than the required 24 hours. The 1-inch diameter orifice used for the pond design is smaller than the calculated orifice size (diameter of 1.10 inches) from earlier in the Design Procedure. The smaller orifice gives a conservative design with a higher detention time for WQ_v .



Example Design

Second Iteration

If required or desired, a second iteration may be performed to attempt to adjust the pond configuration to try to get the detention time closer to 24 hours or to fit other site constraints. Another modification that could affect the pond's detention time would be to include a forebay that would store a portion of WQ_v .

The Example Design will not include the final three design steps (Steps 13-15), but these steps would be incorporated into a full pond design.

STEP 13 – Prepare the vegetation and landscaping plan.

STEP 14 – Prepare the operation and maintenance plan.



**City of Berea, KY
Stormwater Best Management Practices**

3.4 POST CONSTRUCTION STORMWATER CONTROL FACT SHEETS (PTP)

| | |
|---|---|
| <p>Post Construction Stormwater Control Practices</p> | <p>3.4.9 Oil and Grease/Water Separator</p> |
|  <p>Symbol</p>  <p>TSS Reduction: 40%</p> |  |

Description

REASONS FOR LIMITED USE

- Cannot alone achieve the 80% TSS removal target
- Intended for hotspot, space-limited or pretreatment applications
- Limited performance data

KEY CONSIDERATIONS

- Intended for the removal of settleable solids (grit and sediment) and floatable matter, including oil and grease
- Dissolved pollutants are not effectively removed
- Frequent maintenance required
- Performance dependent on design and frequency of inspection and cleanout of unit.
- Must have adequate capacity to accommodate spills

Applications

Gravity separators (also known as oil/water separators) are hydrodynamic separation devices that are designed to remove grit and heavy sediments, oil and grease, debris and floatable matter from stormwater runoff through gravitational settling and trapping. Gravity separator units contain a permanent pool of water and typically consist of an inlet chamber, separation/storage chamber, a bypass chamber, and an access port for maintenance purposes. Runoff enters the inlet chamber where heavy sediments and solids drop out.



City of Berea, KY Stormwater Best Management Practices

Applications

The flow moves into the main gravity separation chamber, where further settling of suspended solids takes place. Oil and grease are skimmed and stored in a waste oil storage compartment for future removal. After moving into the outlet chamber, the clarified runoff is then discharged. The performance of these systems is based primarily on the relatively low solubility of petroleum products in water and the difference between the Gravity separators are *not* designed to separate other products such as solvents, detergents, or dissolved pollutants. The typical gravity separator unit may be enhanced with a pretreatment swirl concentrator chamber, oil draw-off devices that continuously remove the accumulated light liquids, and flow control valves regulating the flow rate into the unit.

Gravity separators are best used in commercial, industrial and transportation land uses and are intended primarily as a pretreatment measure for high-density or ultra urban sites, or for use in hydrocarbon hotspots, such as gas stations and areas with high vehicular traffic. However, gravity separators cannot be used for the removal of dissolved or emulsified oils and pollutants such as coolants, soluble lubricants, glycols and alcohols. Since resuspension of accumulated sediments is possible during heavy storm events, gravity separator units should be installed off-line. Gravity separators are available as prefabricated proprietary systems from a number of different commercial vendors.

Design

Section 2.7 outlines the criteria and approval process for proprietary or manufactured BMPs within the City limits. Where the water quality unit is not rated for full treatment (80% TSS reduction), additional permanent treatment practices are required. Water quality units are not typically designed for stormwater quantity control as well, so a detention structure such as a detention pond will be required.

For water quality units designed based upon a flow rate, the following equation must be used to simulate treatment of the WQv:

$$Qp = C * I * A$$

Where:

Qp = the peak flow through the proprietary BMP in cfs

C = runoff coefficient

I = rainfall intensity, 2.45 in/hr

A = the contributing drainage area for the BMP, in acres

The use of gravity (oil/water) separators should be limited to the following applications:

- Pretreatment for other structural stormwater controls
- High-density, ultra urban or other space-limited development sites
- Hotspot landuse areas where the control of grit, floatables, and/or oil and grease are required

Gravity separators are typically used for areas less than 5 acres. It is recommended that the contributing area to any individual gravity separator be limited to 1 acre or less of impervious cover.



City of Berea, KY Stormwater Best Management Practices

Design

Gravity separator systems can be installed in almost any soil or terrain. Since these devices are underground, appearance is not an issue and public safety risks are low.

Gravity separators are rate-based devices. This contrasts with most other stormwater structural controls, which are sized based on capturing and treating a specific water quality volume.

Gravity separator units are typically designed to bypass runoff flows in excess of the design flow rate. Some designs have built-in high flow bypass mechanisms. Other designs require a diversion structure or flow splitter ahead of the device in the drainage system. An adequate outfall must be provided.

The separation chamber should provide for three separate storage volumes:

1. A volume for separated oil storage at the top of the chamber
 2. A volume for settleable solids accumulation at the bottom of the chamber
 3. A volume required to give adequate flow-through detention time for separation of oil and sediment from the stormwater flow
- The total wet storage of the gravity separator unit should be at least 400 cubic feet per contributing impervious acre.
 - Horizontal velocity through the separation chamber should be 1 to 3 ft/min or less. No velocities in the device should exceed the entrance velocity.
 - The minimum depth of the permanent pools should be 4 feet.
 - A trash rack should be included in the design to capture floating debris, preferably near the inlet chamber to prevent debris from becoming oil impregnated.
 - Ideally, a gravity separator design will provide an oil draw-off mechanism to a separate chamber or storage area.
 - Adequate maintenance access to each chamber must be provided for inspection and cleanout of a gravity separator unit.
 - Gravity separator units should be watertight to prevent possible groundwater contamination.
 - The design criteria and specifications of a proprietary gravity separator unit should be obtained from the manufacturer.



City of Berea, KY Stormwater Best Management Practices

Maintenance A maintenance and operation plan must be provided for each water quality unit. This information can be provided by the manufacturer and must address the following items:

- Expected clean out frequency
- Unit life expectancy
- Procedures addressing dewatering of the unit, should it get clogged
- A cross sectional view of the unit with all overflow structures, weirs, pipe connections clearly identified
- The bypassing mechanism and any maintenance requirements for that component



Additional maintenance requirements for a proprietary system should be obtained from the manufacturer.

Failure to provide adequate inspection and maintenance can result in the resuspension of accumulated solids. Frequency of inspection and maintenance is dependent on land use, climatological conditions, and the design of gravity separator.

Proper disposal of oil, solids and floatables removed from the gravity separator must be ensured.

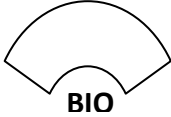

3.4 POST CONSTRUCTION STORMWATER CONTROL FACT SHEETS (PTP)

| Post Construction Stormwater Control Practices | 3.4.10 Bioretention Systems |
|--|---|
|  <p>BIO Symbol</p>  <p>BIO</p> <p>TSS Reduction: 80%</p> |  |
| <p>Description</p> | <p>Bioretention systems are structural water quality control devices that capture and temporarily store, treat, and release stormwater runoff. A properly designed area will replicate a small, dense forest floor. Bioretention systems consist of two main components: a pretreatment area and filtration chamber. The pretreatment area removes floatable materials and heavy sediments, and helps reduce flow velocities. The filtration chamber traps and strains pollutants, and allows the microbial removal of pollutants. Target pollutants for bioretention systems include suspended solids, suspended particulates, biochemical oxygen demand (BOD), fecal coliform bacteria, and others. Bioretention systems employ organic materials such as peat or compost combined with sand, and plantings and mulch on the surface layer. This allows additional pollutant removal via bacterial decomposition and vegetation uptake of nutrients. The two main structures of bioretention systems (the pretreatment area and filtration area) may include or be enhanced by the following components:</p> <ul style="list-style-type: none">➤ Grass filter strip➤ Sand bed➤ Ponding area or pretreatment basin➤ Organic layer➤ Planting soil layer➤ Plant material➤ Underdrain/collection system |



City of Berea, KY Stormwater Best Management Practices

Applications

Bioretention systems are often used to manage stormwater runoff from urban areas where space is limited, and can be applied to areas where retrofit is needed, and are typically suitable in the following applications:

- Small stabilized drainage areas
- Drainage areas with high impervious cover
- Off-line facilities adjacent to parking lots
- Along road drainage swales
- Within larger landscaped pervious areas
- Landscaped islands in impervious or high-density environments (i.e. parking lots)
- Retrofitting existing parking lot islands/off-line facilities

Bioretention systems are **not** suitable in the following applications:

- Within drainage areas that have not been stabilized
- Areas with mature trees
- Adjacent to areas with slopes greater than 5:1 (H:V)
- Areas that experience continuous flow from surface water, groundwater, sump pumps, or other sources

Bioretention systems should only be applied to stabilized drainage areas, as heavy sediment loads from construction areas will clog and disable it. Likewise, they should not be used in areas where stormwater has potential for high silt or clay content, and areas with a high water table. As a guide, sites implementing bioretention systems should have over 50% impervious cover in the drainage area.

Bioretention systems should typically be designed for off-line use to capture the first flush of runoff. A diversion structure such as a flow splitter or weir may be necessary to separate and route the first flush to the bioretention system for water quality control, and route the remaining stormwater to a water quantity control device downstream. Other options include an overflow structure that carries flows larger than the water quality treatment requirement. Bioretention systems are most effective when turbulent flow is minimized and the flow is spread uniformly across the surface area.

Bioretention is best employed close to the source of runoff generation and is often located in the upstream portion of the stormwater treatment train, with additional stormwater BMPs following downstream. Strong consideration should be given to multiple smaller bioretention systems rather than one large bioretention system.



Bioretention System Variations **FILTRATION/PARTIAL RECHARGE FACILITY**

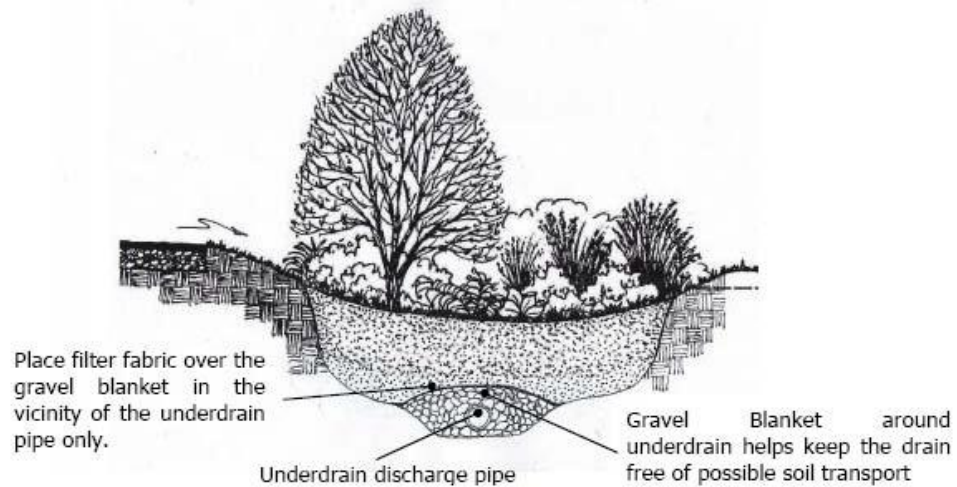

Figure PTP-10- 1 Filtration/Partial Recharge Facility
Source, Minnesota Stormwater Manual

This type of facility is suitable for areas where high filtration and partial recharge of runoff would be beneficial. This facility is designed with an under-drain at the invert of the planting soil mix to ensure that the facility drains at a desired rate. The facility allows for partial recharge, as an impervious liner is not used. The depth is also shallow (2.5') to allow the facility to handle high capacity flows if necessary. Siting of this performance type is suitable for visually prominent or gateway locations in a community. The facility type is suitable for areas and land uses that are expected to generate nutrient and metals loadings (residential, business campus, or parking lots). Attention to mulch type and amount will ensure the adequate treatment of the anticipated loadings. The facility shown above incorporates a filter material between the gravel blanket around the under-drain and the planting soil above. The filter fabric does not need to extend to the side walls. The filter fabric may be installed horizontally above the gravel blanket-extending just 1-2 feet on either side of the under-drain pipe below. Do **not** wrap the under-drain with filter fabric. Instead of using a filter fabric, the designer may opt to utilize a pea gravel diaphragm over the under-drain gravel blanket. This type of facility is also recommended for tight impermeable soils where infiltration is limited. Some volume reduction will be seen from evapotranspiration.



Bioretention System Variations INFILTRATION/FILTRATION/RECHARGE FACILITY

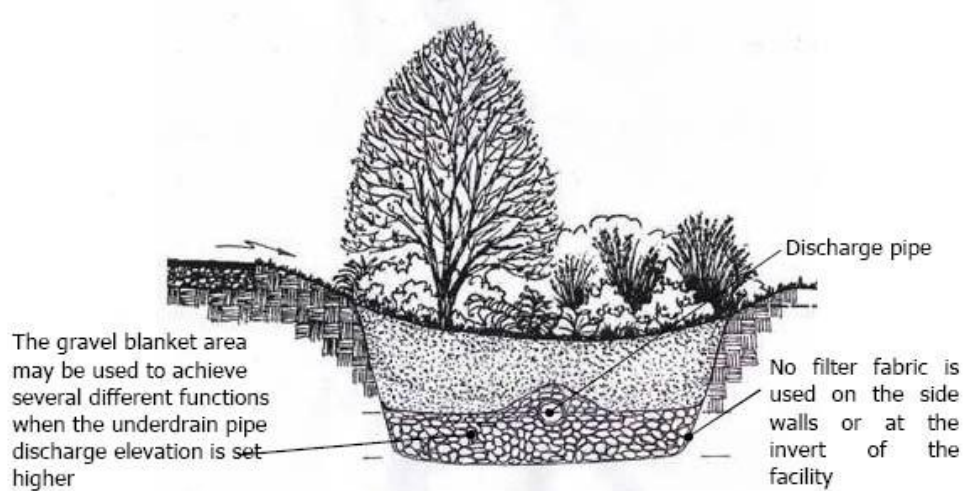

Figure PTP-10- 2 Infiltration/Filtration/Recharge Facility

Source, Minnesota Stormwater Manual

This type of facility is recommended for areas where higher nutrient loadings (particularly nitrates) are anticipated. The facility is designed to incorporate a fluctuating aerobic/anaerobic zone below the raised under-drain discharge pipe. This fluctuation created by saturation and infiltration into the surrounding soils will achieve de-nitrification. With a combination of a fresh mulch covering, nitrates will be mitigated through the enhancement of natural denitrification processes. This type of facility would be suitable for areas where nitrate loadings are typically a problem (residential communities). The raised under-drain has the effect of providing a storage area below the invert of the under-drain discharge pipe. This area provides a recharge zone and quantity control can also be augmented with this storage area. The storage area is equal the void space of the material used.



Bioretention System Variations **FILTRATION ONLY FACILITY**

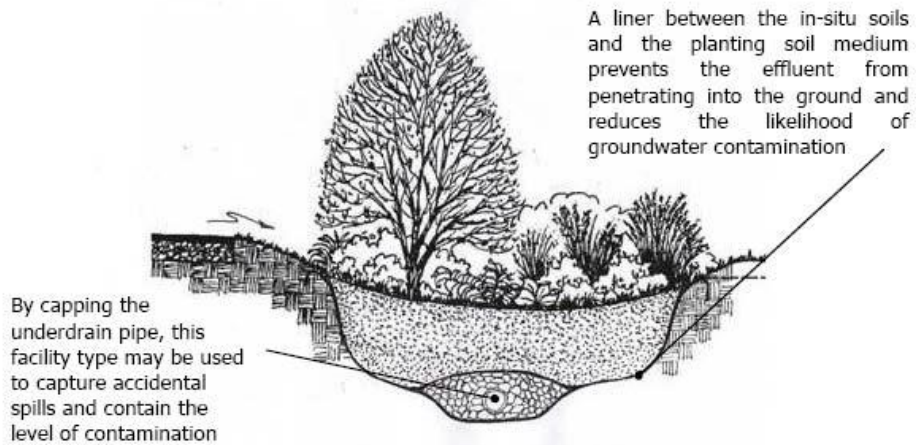

Figure PTP-10- 3 Filtration Only Facility
Source, Minnesota Stormwater Manual

This type of facility is recommended for areas that are known as potential stormwater “hot-spots” (gas stations, transfer sites, and transportation depots). An important feature of this type of facility is the impervious liner designed to reduce or eliminate the possibility of ground water contamination. The facility provides a level of treatment strictly through filtration processes that occur when the runoff moves through the soil material to the underdrain discharge point. In the event of an accidental spill, the under-drain can be blocked and the objectionable materials siphoned through the observation well and safely contained.



City of Berea, KY Stormwater Best Management Practices

Maintenance

Maintenance access should be provided for appropriate equipment, vehicles, and personnel.

Monthly

- Remove trash or debris
- Inspect the bioretention system for clogging
- Pruning and weeding to maintain appearance.
- Mulch replacement when erosion is evident.

Semi-annually

- The planting soils should be tested for pH to establish acidic levels. If the pH is below 5.2, limestone should be applied. If the pH is above 7.0 to 8.0, then iron sulfate plus sulfur can be added to reduce the pH.

Annually

- Remove sediment as necessary
- Repair or replace any damaged structural parts
- Stabilize any eroded areas
- Replace mulch over the entire area.
- Replace gravel diaphragm if warranted every 2 to 3 years.

As Needed

- Inspect inflow points for clogging (off-line systems). Remove any sediment.
- Inspect grass filter strip/grass channel for erosion or gullyng. Re-seed or sod as necessary.
- Trees and shrubs should be inspected to evaluate their health and remove any dead or severely diseased vegetation.
- Ponding of water on the surface for more than 48 hours indicates that the filtering capacity is substantially diminished. Replace mulch layer by removing the top few inches that contain sediment. Core aeration or cultivating of unvegetated areas may also be required to ensure adequate filtration. The removed sediment should be disposed of properly, such as in a landfill.
- Silt or sediment should be removed from the bioretention system at the accumulation of approximately 2 inches.
- Properly dispose of any material generated during maintenance activities.



City of Berea, KY Stormwater Best Management Practices

Inspection Checklist

Monthly

- Contributing area, facility, inlets, and outlets are clear of debris
- Contributing area is stabilized and mowed, with clippings bagged or removed
- Treatment area is not clogging – also inspect after moderate/major storm events
- Activities in the drainage area minimize oil/grease and sediment entering the system
- Standing water is not present
- No erosion is present in the bioretention system
- Pretreatment area shows no evidence of erosion
- Deposition of sediment should be no more than 2 inches before it is cleaned out

Annually

- Treatment area contains no more than 2 inches of sediment
- No evidence of deterioration, spalling, or cracking is present on concrete, if present
- Inspect grates, where applicable
- Inlets, outlets, and overflow spillways or diversion structures show no evidence of erosion or deterioration
- Flow is not bypassing the bioretention system
- Wetland vegetation is not present in the bioretention area (signifies poor drainage)



Figure PTP-10- 4 Bioretention System

Source, *Maryland Department of Natural Resources*



City of Berea, KY Stormwater Best Management Practices

Design Criteria

- The size of the drainage area typically dictates the size of the bioretention practice. These areas should be limited to a maximum contributing drainage area of five (5) acres. One-half (0.5) to two (2) acre drainage areas are preferred. Multiple bioretention areas may be required for larger drainage areas. No more than 50 percent of the drainage area can be pervious.
- Sloped areas immediately adjacent to the bioretention system should be no greater than 5:1 (H:V) nor less than 1% to promote positive flow toward the system.
- Bioretention systems should be sized based on the principles of Darcy's Law, as shown in the Design Procedures section. However, the minimum size of a bioretention system is 200 square feet (equivalent to 10-feet wide and 20 feet long).
- The bioretention system surface slope should not exceed 1%, to promote even distribution of flow throughout the system.
- The maximum side slopes for a bioretention system is 3:1 (H:V).
- Planting soils should contain less than 5% clay by volume. Additional specifications for soils are outlined in the Design Components section.
- Where feasible ponding depths should be no greater than 6 inches. The maximum allowable pooling depth is 18 inches.
- The bioretention system should be designed such that it is drained within 48 hours from the peak water level in the system.
- Bioretention systems require pre-treatment and as many pretreatment components as feasible should be incorporated. Pretreatment components are described below.
 - For applications where runoff enters the bioretention system through sheet flow, such as from parking lots, or residential back yards, a grass filter strip with a gravel diaphragm is the preferred method of pretreatment.
 - For applications where concentrated (or channelized) runoff enters the bioretention system, such as through a slotted curb opening, a grassed channel with a gravel diaphragm is the preferred method of pretreatment.
- Underdrains are required in bioretention systems to carry flow to another conveyance element. The underdrains should be equipped with a minimum 8-inch perforated PVC pipe surrounded by a 12-inch thick gravel layer. The underdrain can be installed at the bottom of the storage area or at an elevation above the bottom of the storage area, depending on the treatment goals for the system.
- When designing the underdrain, infiltration of the in situ soils should not be considered. Zero drawdown through the in situ soils should be assumed. The underdrain system must be sized to drain the entire water quality volume (WQ_v) within 48hrs
- The elevation difference from the inflow to the outflow must be 4-6 feet.
- A minimum of 3 feet (5 feet recommended) of separation must be provided between the bottom of the bioretention system and seasonally saturated soils.
- Potential for erosion of stabilized areas and the bioretention system should be evaluated.
- Bioretention systems must have a detailed landscaping plan.



City of Berea, KY Stormwater Best Management Practices

Design Components

- **Pre-treatment** – Pre-treatment areas capture and remove coarse sediment particles from runoff prior to discharging into the bioretention area. Incorporation of pretreatment components helps to reduce the maintenance burden of bioretention, and reduces the likelihood that the planting soil layer will clog over time.
 - **Gravel Diaphragm** – Located at the beginning of the grass buffer strip to reduce velocity of runoff, filter particles in the stormwater, and spread flow across the grass buffer strip.
 - **Grass Buffer Strip/Grass Channel** – Reduces velocity of runoff and filters particles in the stormwater. The length of the grass buffer strip depends on the drainage area, imperviousness, and the buffer strip slope. When bioretention is used to treat runoff from parking lots or roadways that are frequently sanded during snow events, grass buffer strips should be a minimum of 10 feet long and grass channels a minimum of 20 feet long.
 - **Concrete Forebay or Curb** – Often bioretention areas are incorporated into parking lots and other highly impervious areas. Curbs and/or concrete forebays can be constructed to slow runoff and allow larger solids to settle before reaching the bioretention area. Curbs can simply have a lip set 1-2 inches above the parking lot elevation and effectively settle large particles. A concrete forebay can also be installed to aid maintenance and cleaning.
 - **Ponding Area or Pretreatment Basin** – Runoff is detained to settle particulates suspended in stormwater.

- **Treatment** –
 - **Surface/Ponding Area** –The surface area of all infiltration based bioretention systems is a function of the infiltration capacity of the underlying soils. The surface area of all filtration based bioretention practices is a function of the filtration capacity of the soil medium and underdrain. Ponding depths should be kept to a minimum to reduce hydraulic overload of in-situ/planting soils and to maximize the surface area to system depth ratio, where space allows. It is recommended that approximately 5-10% of the tributary impervious area be dedicated to the bioretention system footprint.
 - **Organic Layer** – A layer of mulch filters pollutants out of the stormwater and protects soil from eroding. The layer can also sustain a nutrient rich environment with microbes that can break down petroleum-based contaminants. The layer should contain approximately 2 to 3 inches fresh shredded bark mulch, when possible, to maximize nitrogen retention. If aged mulch is used, use the shredded type instead of the “chip” variety to minimize floating action. Too much mulch can restrict oxygen flow to roots.



City of Berea, KY Stormwater Best Management Practices

Design Components

- **Planting Soil Layer** – This layer is used to provide nutrients and store water for the area’s plantings.
 - The planting soil should be a well blended, homogenous mixture of 50-60% construction sand, 20-30% top soil, and 20-30% organic leaf compost. This blend is necessary to provide a planting soil layer with a high infiltration/filtration capacity.
 - Field experiments show that pollutant removal is accomplished within the top 30” of soil depth with minimal additional removal beyond that depth (Prince George’s County, 2002). Therefore, the recommended depth of the prepared soil is 30 inches. However, if large trees are preferred in the design, a soil depth of 48”-52” should be utilized. The soil depth generally depends upon the root depth of the prescribed vegetation and content of underlying soils.
 - Clay material can absorb heavy metals, hydrocarbons and other pollutants. However, clay should be mixed with sand or topsoil such that the planting soil layer has a clay content of less than 5%.
 - Additionally, the design permeability rate through the planting soil bed should be high enough to fully drain the stormwater quality design storm runoff within 48hrs. It is recommended that this permeability rate be determined by field testing.
 - The planting soil should have a pH ranging from 5.5 to 6.5.
- **Plant Material** – Consider surrounding environment, climate, maintenance requirements and types of pollutants that the plants must withstand and treat, while maintaining a positive aesthetic enhancement.
- **Underdrain/Collection System** – Necessary to collect and send flows to a stormwater conveyance system. This system should contain a minimum 8-inch perforated PVC pipe surrounded by a 12-inch thick gravel layer. The gravel shall be washed and 1-1/2” in size. Increasing the diameter of the underdrain makes freezing less likely, and provides a greater capacity to drain standing water from the system. Pipe perforations should be sized approximately 3/8 inch in diameter spaced at 6-inch intervals on center. At a minimum, 4 holes per row should be used, and pipe grade placement should be at least 0.5%. Pipes should be spaced no more than 10 feet on center. The porous gravel layer prevents standing water in the system by promoting drainage. Gravel is also less susceptible to frost heaving than finer grain media. A pea gravel diaphragm and/or permeable filter fabric should be placed between the gravel layer and the planting soil layer.



City of Berea, KY Stormwater Best Management Practices

Landscaping

- Impervious area construction must be completed and a dense and vigorous vegetative cover should be established over the contributing pervious drainage areas **BEFORE** runoff can be accepted into the bioretention system.
- Consult with a landscaping professional to select vegetation which fits into the landscape, is appropriate for the hardiness zone, and can tolerate conditions found in bioretention areas (short durations of 6 inch ponding water). Vegetation should be selected based on specified zone of hydric tolerance.
- The bioretention area should be vegetated to resemble a terrestrial forest ecosystem, with a mature tree canopy, sub canopy of under story trees, shrub layer, and herbaceous ground cover. Three species each of both trees and shrubs are recommended to be planted. Many bioretention systems feature wild flowers and grasses in addition to trees and shrubs. Other typical landscape plants can be used, such as day lilies, landscape grasses, or other native plantings.
- The tree-to-shrub ratio should be 2:1 to 3:1. On average, the trees should be spaced 8 feet apart. Plants should be placed at regular intervals to replicate a natural forest.
 - Woody vegetation should not be specified at inflow locations.
 - Trees should not be planted directly over top of underdrains and may be best located along the perimeter of the system.
- After the trees and shrubs are established, the ground cover and mulch should be established. Mulch should not be mounded around the base of plants since this encourages damage from pests and diseases.
- Salt resistant vegetation should be used in locations with probable adjacent salt applications, i.e. roadside, parking lot, etc.
- Choose plants based on factors such as resistance to drought and inundation, cost, aesthetics, maintenance, etc. Native plant species should be specified over non-native species.
- Fluctuating water levels following seeding (prior to germination) can cause seed to float and be transported. Seed is also difficult to establish through mulch, a common surface component of bioretention systems. It may take up to two growing seasons to establish the function and desired aesthetic of mature vegetation via seeding. Therefore mature plantings are recommended over seed.
- If a minimum coverage of 50% is not achieved after the first growing season, a reinforcement planting is required.
- Bioretention system locations should be integrated into the site planning process, and aesthetic considerations should be taken into account in the siting and design.



City of Berea, KY Stormwater Best Management Practices

Design Procedure

Step 1 – Make a preliminary judgment as to whether site conditions are appropriate for the use of a bioretention system, and identify the function of bioretention in the overall treatment system.

- Consider basic issues for initial suitability screening, including:
 - Site drainage area
 - Site topography and slopes
 - Soil infiltration capacity
 - Site location/minimum setbacks
 - Presence of active karst features
- Determine how the bioretention system will fit into the overall stormwater treatment system.
 - Decide whether the bioretention system is the only BMP to be employed, or if there are other BMPs addressing some of the treatment requirements.
 - Decide where on the site the bioretention system is most likely to be located.

Step 2 – Confirm design criteria, site constraints, and applicability.

- Determine the design criteria that will be used.
- Determine any constraints the site will place on the bioretention system such as:
 - High pervious area in the drainage area
 - Limited amount of surface area available for treatment
 - High water table
 - Water surface elevation in any downstream treatment practices or conveyance
- Ensure that stormwater runoff from impervious surfaces is being treated to the 80% TSS reduction standard.
 - The equation for determining the weighted TSS reduction for a site with multiple outlet points is below.

$$\%TSS = \frac{\sum_n^1 (TSS_1 A_1 + TSS_2 A_2 + \dots + TSS_n A_n)}{\sum_n^1 (A_1 + A_2 + \dots + A_n)}$$

Where:

TSS₁ = TSS reduction by BMP providing treatment for A₁

A₁ = area 1, (acres)

TSS₂ = TSS reduction by BMP providing treatment for A₂

A₂ = area 2, (acres)

- Where one BMP discharges into another, the treatment train TSS reduction can be found by the following equation:

$$TSS_{rain} = A + B - \frac{(A \times B)}{100}$$



City of Berea, KY Stormwater Best Management Practices

Design Procedure

Where:

TSS_{train} = total TSS reduction through successive BMPs

A = TSS reduction through first BMP

B = TSS reduction through second BMP

Step 3 – Perform field verification of site suitability.

- Determine the depth to groundwater. A minimum of 3 feet of separation between the bottom of the bioretention system and seasonally saturated soils (or from bedrock) is required (5 feet recommended).
- The field verification should be conducted by a qualified geotechnical professional.
- If the initial evaluation indicates that a bioretention practice would be a good BMP for the site, it is recommended that soil borings or pits be dug (in the same location as the proposed bioretention practice) to verify soil types and infiltration capacity characteristics and to determine toe depth to ground water and bedrock. The number of soil borings should be selected as needed to determine local soil conditions.

It is recommended that the minimum depth of the soil borings or pits be five feet below the bottom elevation of the proposed bioretention system.

Step 4 – Compute runoff control volumes and peak flows.

- Calculate the Water Quality Volume (WQ_v), peak runoff for the 25 year storm (Q_{P25}), and the peak runoff for the 100 year storm (Q_{P100}). Refer to Section 2 for more information stormwater quantity design.
 - The required water quality treatment volume is 1.1 inches of runoff from the new impervious surfaces created from the project.
 - Determine Water Quality Volume (WQ_v).

$$WQ_v = [P R_v(A)]/12$$

Where:

P = is the average rainfall, (inches)

R_v = $0.05 + 0.009(I)$, where I is the percent impervious cover

A = the area of imperviousness, (acres)

- Calculate the peak flows for Q_{P25} and Q_{P100} to meet detention requirements.



City of Berea, KY Stormwater Best Management Practices

Design Procedure

Note: Steps 5-8 are iterative

Step 5 – Determine bioretention type and size.

- Select type of bioretention basin – after completion of the previous steps the designer should know the depth to the water table, bedrock or other impermeable layers, and the contributing drainage area.
 - Determine Water Quality Volume (WQ_v) for bioretention system.
 - If part of the overall WQ_v is to be treated by other BMPs, subtract that portion from the WQ_v to determine the part of the WQ_v to be treated by the bioretention system.
 - If the bioretention system has an underdrain the volume of voids in the underdrain system should be subtracted from the WQ_v. The volume of voids should be estimated at 35% of the total volume of the underdrain system.
 - Based on the known WQ_v, infiltration rates of the underlying soils and the known existing potential pollutant loading from proposed/existing landuse select the appropriate bioretention type (see Section 2.6).
- Size Bioretention System With An Underdrain
 - The bioretention surface area is computed using the following equation, for those systems that are designed with an underdrain:

$$A_f = (WQ_v \times d_f) / [k \times (h_f + d_f) \times t_f]$$

Where:

A_f = surface area of bioretention system, (ft²)

WQ_v = water quality volume, (ft³)

d_f = filter bed depth, (ft)

k = coefficient of permeability of filter media, (ft/day) (0.5 ft/day is the recommended k for planting medium / filter media soil. This value is conservative to account for clogging associated with accumulated sediment.)

h_f = average height of water above filter bed, (ft)

t_f = design filter bed drain time, (days)

(48 hours is the required maximum t_f for bioretention)

STEP 6 – Size outlet structure and/or flow diversion structure, if needed.

- It is required that a secondary outlet be incorporated into the design of a bioretention system to safely convey excess stormwater. Stormwater quantity requirements can be found in Section 2.4.7.
- Potential for erosion to stabilized areas and bioretention system should be evaluated and the design should incorporate ways to mitigate erosive flows.



City of Berea, KY
Stormwater Best Management Practices

Design Procedure

STEP 7 – Determine pre-treatment volume and design pre-treatment measures.

- Some form of pre-treatment is required prior to the discharge of stormwater into the bioretention system, to remove any sediment and fines that may result in clogging of the soils in the treatment area.
- Grass filter strips should be sized based on the following table.

Table PTP-10- 1 Grass Filter Strip Sizing (*Minnesota Stormwater Manual*)

| Parameter | Impervious Parking Lots | | | | Residential Lawns | | | |
|-----------------------------|-------------------------------------|-----|-----|-----|-------------------|-----|-----|-----|
| | Maximum Inflow Approach Length (ft) | 35 | | 75 | | 75 | | 150 |
| Filter Strip Slope | ≤2% | >2% | ≤2% | >2 | ≤2% | >2% | ≤2% | >2% |
| Filter Strip Minimum Length | 10' | 15' | 20' | 25' | 10' | 12' | 15' | 18' |

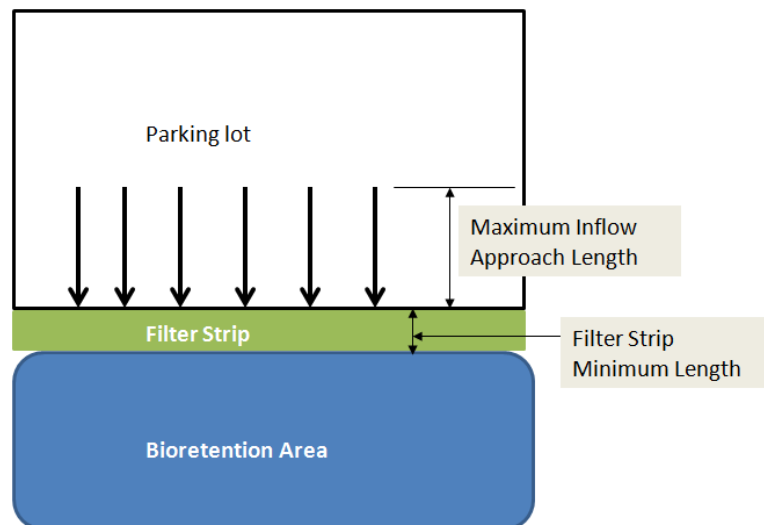

Figure PTP-10- 1. Filter Strip Design Parameters

- Grass channels should be a minimum of 20 feet in length and designed according to the following.
 - Parabolic or trapezoidal cross-section with bottom widths between 2 and 8 feet.
 - Channel side slopes no steeper than 3:1 (H:V)
 - Flow velocities limited to 1 foot per second or less for peak flow associated with the water quality event storm.

Flow depth of 4 inches or less for peak flow associated with the water quality event storm.

STEP 9 – Prepare vegetation and landscaping plan

- Prepare vegetation and landscaping management plan based on the guidance given in the Landscaping Section.

STEP 10 – Prepare operations and maintenance plan

Prepare operations and maintenance plan based on the guidance given in the Maintenance Section.



City of Berea, KY
Stormwater Best Management Practices

Design Procedure

STEP 11 – Complete the Design Summary Table.

| Design Parameter | Required Size | Actual Size |
|-------------------------|----------------------|--------------------|
| WQ _v | | |
| Underdrain storage, Su | | |
| Treatment area, Af | | |
| Ponding depth | | |
| Treatment area (LxW) | | |



**City of Berea, KY
Stormwater Best Management Practices**

**Example
Design**



Proposed development of an undeveloped site into an office building and associated parking.

| <p>Base Data Total Drainage Area = 5 ac Site Area = 3.54 ac Soils Type "C"</p> <p>Pre-Development Impervious Area = 0 ac; or I = 0% Meadow (CN = 71)</p> <p>Post-Development Impervious Area = 1.72 ac; or I = 1.72/3.54 = 49% Open Space, Fair (CN = 79) Paved parking lots, roofs, driveways, etc. (CN = 98)</p> | <p>Hydrologic Data</p> <table border="1"> <thead> <tr> <th></th> <th>Pre</th> <th>Post</th> </tr> </thead> <tbody> <tr> <td>CN</td> <td>71</td> <td>89</td> </tr> </tbody> </table> <p>WQ_v Depth = 1.1 in</p> <p>Precipitation</p> <table border="1"> <tbody> <tr> <td>2yr, 24hr</td> <td>3.54 in</td> </tr> <tr> <td>25yr, 24hr</td> <td>5.88 in</td> </tr> <tr> <td>100yr, 24hr</td> <td>7.43 in</td> </tr> </tbody> </table> | | Pre | Post | CN | 71 | 89 | 2yr, 24hr | 3.54 in | 25yr, 24hr | 5.88 in | 100yr, 24hr | 7.43 in |
|---|---|------|-----|------|----|----|----|-----------|---------|------------|---------|-------------|---------|
| | Pre | Post | | | | | | | | | | | |
| CN | 71 | 89 | | | | | | | | | | | |
| 2yr, 24hr | 3.54 in | | | | | | | | | | | | |
| 25yr, 24hr | 5.88 in | | | | | | | | | | | | |
| 100yr, 24hr | 7.43 in | | | | | | | | | | | | |



City of Berea, KY Stormwater Best Management Practices

Example Design

This example focuses on the design of a bioretention facility to meet the water quality treatment requirements of the site. In general, the primary function of bioretention is to provide water quality treatment and not large storm attenuation. As such, flows in excess of the water quality volume are typically routed to bypass the facility or non-erosively pass through the facility. Where quantity control is required, the bypassed flows can be routed to conventional detention basins (or some other facility such as underground storage vaults).

Problem: Design a water quality treatment plan for this site. A dry detention pond will be constructed to meet the required detention standards and will provide 60% TSS reduction for the site. The total drainage area to the pond is 5 ac. Include multiple bioretention systems in the landscape islands in the parking area to meet the water quality goal of 80% TSS reduction.

Step 1 – Make a preliminary judgment as to whether site conditions are appropriate for the use of a bioretention system, and identify the function of bioretention in the overall treatment system.

- Consider basic issues for initial suitability screening, including:
 - The site has type “C” soils
 - There are no minimum setbacks
 - There are active karst areas on the site. Bioretention systems will not be located close to the sinkhole.

- Determine how bioretention system will fit into the overall stormwater treatment system.
 - Bioretention systems will be constructed in combination with a dry detention pond for water quality and quantity control on the site. Design of the dry detention pond can be found in Section 4.8.
 - Landscaping islands in the parking lot are likely spaces for bioretention systems.
 - The treated water quality volume will be collected by an underdrain and routed to the dry pond located in the northwest corner of the site for water quantity control. Flows greater than the water quality volume will bypass the bioretention systems and be routed to the dry pond for water quantity control and treatment prior to discharging.

Step 2 – Confirm design criteria, site constraints, and applicability.

- The following minimum criteria will be used in the design.
 - Minimum 200 sq ft of surface area
 - Maximum 6 in ponding depth
 - Maximum 48hr drain time from peak water level
 - Minimum 8 in underdrain enveloped in a 12 in gravel layer
 - Minimum 3 ft separation from bottom to seasonally saturated soils

- Determine any constraints the site will place on the bioretention system:
 - Do not place bioretention near sinkhole



City of Berea, KY Stormwater Best Management Practices

Example Design

- Ensure that stormwater runoff from impervious surfaces is being treated to the 80% TSS reduction standard.
 - Determining the weighted TSS reduction.

Bioretention Systems have an 80% TSS reduction, and all stormwater runoff from impervious surfaces flow through one of three bioretention facilities. Therefore, a weighted TSS calculation is not necessary.
 - Determine the treatment train TSS reduction.

After the water quality volume is treated by bioretention, it is then treated in the dry pond before leaving the site. Bioretention Systems have an 80% TSS reduction. Dry ponds have a 60% TSS reduction.

$$TSS_{rain} = A + B - \frac{(A \times B)}{100}$$

Where:

$$A = 80\%$$

$$B = 60\%$$

$$TSS_{rain} = 80 + 60 - \frac{(80 \times 60)}{100}$$

$$TSS_{rain} = 92\%$$

Step 3 – Perform field verification of site suitability.

- The bioretention systems will be designed as filtration BMPs, with the full WQv discharging within 48 hrs through the underdrain. Therefore, the only field testing required is to determine the high water elevation under the BMP locations.

Field soil tests show the high water elevation to be 8 feet or more below the parking lot.

Step 4 – Compute runoff control volumes and peak flows.

- Calculate the Water Quality Volume (WQ_v), Peak Flow Volume (V_{P25}), and the Extreme Flood Volume (V_{P100}).

Total Water Quality Volume:

$$WQ_v = [P R_v(A)]/12$$

Where:

$$P = 1.1 \text{ inches}$$

$$R_v = 0.05 + 0.009(I)$$

$$I = 49$$

$$R_v = 0.05 + 0.009(49) = 0.491$$

$$A = 1.72 \text{ acres}$$

$$WQ_v = (1.1 \text{ in} \times 0.491 \times 1.72 \text{ ac})/12 = 0.077 \text{ acre-ft} = 3372 \text{ ft}^3$$



City of Berea, KY Stormwater Best Management Practices

Example Design

The pre- and post development volumes for both 25-yr and 100-yr 24-hour return frequency storms should be calculated to determine the required water quantity controls. See Appendix B for more information regarding detention and quantity design.

- Calculate the pre- and post-development peak flows for 25 yr (Q_{p25}) and 100 yr (Q_{p100}) storms for the design of flow diversions, outlet structures, and overflow structures.

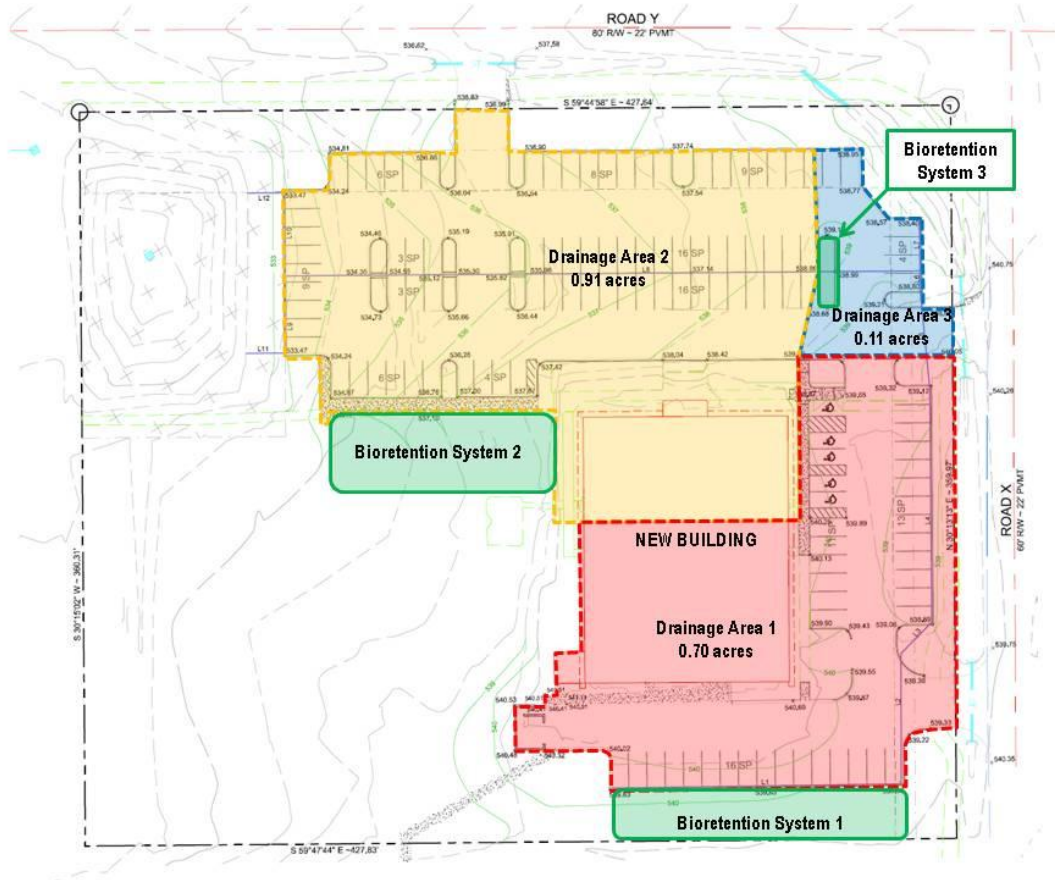



City of Berea, KY Stormwater Best Management Practices

Example Design

Note: Steps 5-8 are iterative

Step 5 – Determine bioretention type and size.

- Select type of bioretention basin
 - The bioretention system will treat the entire water quality volume.
 - The bioretention system will include an underdrain/collection system.
- Determine Water Quality Volume (WQ_v) for bioretention system.
 - Bioretention System 1
 - A₁ = 0.70 ac; I = 100; WQ_v = 3655 ft³
 - Bioretention System 2
 - A₂ = 0.91 ac; I=100; WQ_v = 3452 ft³
 - Bioretention System 3
 - A₃ = 0.11 ac; I=100; WQ_v = 417 ft³
- Size Bioretention System With An Underdrain
 - Set ponding depth at 6 inches (h_f)
 - Set depth of the filter bed at 5 ft (d_f)
 - Design to drain in 48 hours (t_d)
 - Assume 35% storage (S_u) of WQ_v in underdrain gravel layer
 - Computed surface area
 - Bioretention System 1
Assume Underdrain 70 ft long
$$S_u = 0.35 \times 70 \text{ ft} \times [0.5 \times 1 \text{ ft} \times (8 \text{ ft} + 2 \text{ ft})] = 122.5 \text{ ft}^3$$
$$A_f = [(WQ_v - S_u) \times d_f] / [k \times (h_f + d_f) \times t_d]$$
$$= [(3655 \text{ ft}^3 - 122.5 \text{ ft}^3) \times 5 \text{ ft}] / [0.5 \text{ ft/day} \times (0.5 \text{ ft} + 5 \text{ ft}) \times 2 \text{ days}]$$
$$= 3211 \text{ ft}^2$$
 - Bioretention System 2
Assume Underdrain 75 ft long
$$S_u = 0.35 \times 75 \text{ ft} \times [0.5 \times 1 \text{ ft} \times (8 \text{ ft} + 2 \text{ ft})] = 131.25 \text{ ft}^3$$
$$A_f = [(WQ_v - S_u) \times d_f] / [k \times (h_f + d_f) \times t_d]$$
$$= [(3452 \text{ ft}^3 - 131.25 \text{ ft}^3) \times 5 \text{ ft}] / [0.5 \text{ ft/day} \times (0.5 \text{ ft} + 5 \text{ ft}) \times 2 \text{ days}]$$
$$= 3019 \text{ ft}^2$$



City of Berea, KY Stormwater Best Management Practices

Example Design

- Bioretention System 3

Assume Underdrain 25 ft long

$$S_u = 0.35 \times 25 \text{ ft} \times [0.5 \times 1 \text{ ft} \times (8 \text{ ft} + 2 \text{ ft})] = 43.75 \text{ ft}^3$$

$$A_r = [(WQ_v - S_u) \times d_f] / [k \times (h_f + d_f) \times t_f]$$
$$= [(417 \text{ ft}^3 - 43.75 \text{ ft}^3) \times 5 \text{ ft}] / [0.5 \text{ ft/day} \times (0.5 \text{ ft} + 5 \text{ ft}) \times 2 \text{ days}]$$
$$= 339 \text{ ft}^2$$

Bioretention System Cross Sectional View

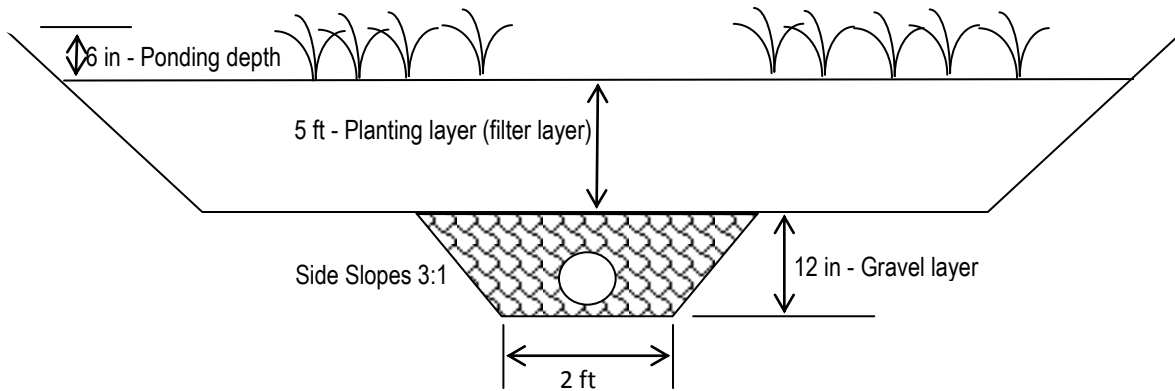

- Determine Dimensions of Bioretention System

- Bioretention System 1

$$A_r = 3211 \text{ ft}^2$$

Length = 120 ft; Width = 27 ft

- Bioretention System 2

$$A_r = 3019 \text{ ft}^2$$

Length = 80 ft; Width = 40 ft

- Bioretention System 3

$$A_r = 339 \text{ ft}^2$$

Length = 30 ft; Width = 12 ft

STEP 7 – Size outlet structure and/or flow diversion structure, if needed.

- A secondary outlet should be designed for the bioretention systems to safely convey excess stormwater.
- Potential for erosion to stabilized areas and bioretention system should be evaluated and the design should incorporate ways to mitigate erosive flows.



City of Berea, KY
Stormwater Best Management Practices

Example Design

STEP 8 – Determine pre-treatment volume and design pre-treatment measures.

- Some form of pre-treatment is required prior to the discharge of stormwater into the bioretention system, to remove any sediment and fines that may result in clogging of the soils in the filtration area.
- Bioretention System 1 will use curb cuts with lips raised 2 inches above the pavement elevation.
- Bioretention System 2 will use a Grass Filter Strip that is sized based on the Table PTP10-1. The maximum inflow length of 205 feet and the filter strip slope is less than 2%. The grass filter strip should be 25 feet long. There will also be a gravel diaphragm prior to the grass filter strip as an additional pretreatment measure.
- Bioretention System 3 will use curb cuts with lips raised 2 inches above the pavement elevation.

STEP 9 – Prepare vegetation and landscaping plan

- Prepare vegetation and landscaping management plan based on the guidance given in the Landscaping Section.

STEP 10 – Prepare operations and maintenance plan

- Prepare operations and maintenance plan based on the guidance given in the Maintenance Section.

STEP 11 – Complete the Design Summary Table

Bioretention Area 1

| Design Parameter | Required Size | Actual Size |
|------------------------|-----------------------|----------------------|
| WQ _v | 3655 ft ³ | |
| Underdrain storage, Su | 122.5 ft ³ | |
| Treatment area, Af | 3211 ft ² | 3240 ft ² |
| Ponding depth | 6 inches | |
| Treatment area (LxW) | 120' x 27' | |



City of Berea, KY
Stormwater Best Management Practices

Example Design

Bioretention Area 2

| Design Parameter | Required Size | Actual Size |
|-------------------------|-----------------------|----------------------|
| WQ _v | 3452 ft ³ | |
| Underdrain storage, Su | 131.5 ft ³ | |
| Treatment area, Af | 3019 ft ² | 3200 ft ² |
| Ponding depth | 6 inches | |
| Treatment area (LxW) | 80'x40' | |

Bioretention Area 3

| Design Parameter | Required Size | Actual Size |
|-------------------------|-----------------------|---------------------|
| WQ _v | 417 ft ³ | |
| Underdrain storage, Su | 43.75 ft ³ | |
| Treatment area, Af | 339 ft ² | 360 ft ² |
| Ponding depth | 6 inches | |
| Treatment area (LxW) | 30'x12'' | |